



ZODIAC



EXPRESS™
*Mineral Sanitizers
for Pools*

For In-ground and Aboveground Pools

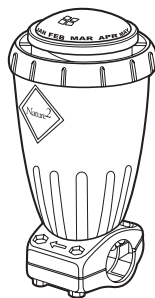

Vessel Installation and Operating Manual

Important Safety Information

Please read this manual prior to installation.

Nature² Express is designed to sanitize in-ground and aboveground swimming pools of up to 25,000 gallons. If your pool is larger than 25,000 gallons do not install this unit but ask your pool professional about a Nature² “G” or “A” model vessel system.



ATTENTION

Failure to heed the following warnings can result in permanent injury, electrocution or drowning.

ELECTRICAL HAZARD

- Severe shock or injury will likely occur as a result of a drill or drill cord coming in contact with water. Never allow electric drill or drill cord to come in contact with water. Only plug drill into a Class A (5 Milliampere Trip) protected Ground Fault Circuit Interrupter (GFCI) in accordance with the National Electrical Code Section 680. Please see your drill owner's manual for further safety precautions.

EQUIPMENT UNDER PRESSURE

- Always turn pump off prior to installing or changing Nature² cartridge. Your pump/filter system is operated under pressure and the pressure must be released before you begin work. Please see your pump/filter owner's manual for further instructions.

PREVENT CHILD DROWNING

- Do not let anyone, especially small children, sit, step, lean or climb on any equipment installed as part of your pool's operational system. Locate the components of your operational system at least 3 feet from the pool so children cannot use the equipment to access the pool and be injured or drown.

IMPORTANT: Pool Owner, save this manual. Builders, leave this manual with pool owner.

Thank you for purchasing a Nature² Express pool sanitizer. Please read through the entire manual before installing your new unit.

Installation

Nature² Express easily installs on your pool's return line. You will need to use a cordless or electric drill to install the vessel.

Nature² Express components: (1) winterizing cap, (2) outer housing, (3) 2" clamp assembly w/gasket (I/G only), (4) 1-1/2" clamp assembly w/gasket, (5) flow diverter, (6) Express cartridge, (7) hole saw, (8) nuts and bolts, (9) silicone tube, (10) rigid PVC adapter (A/G only).

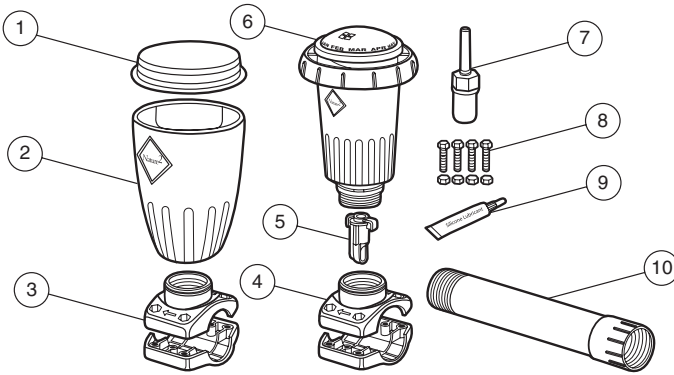

1. Decide where to install the Nature² vessel. It must be installed:
 - After the filter on the main return to the pool.
 - Before or after the heater (downstream of solar heating systems).
 - Before any chemical dispenser or the discharge of any off-line chemical dispenser. **IMPORTANT: Install a check valve before chlorinators to isolate the Nature² vessel from possible backflow of highly chlorinated water.**

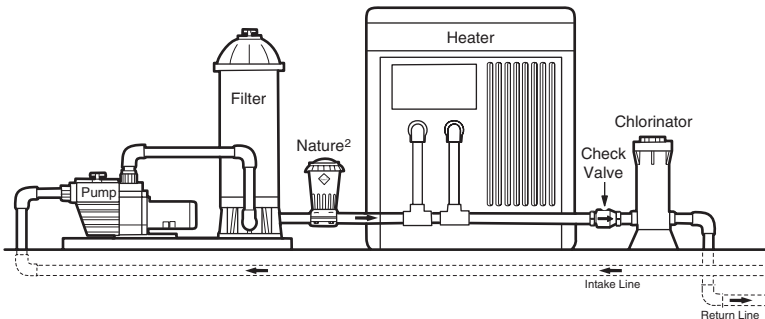

2. Locate the return line. You will need an area of approximately 6" to install your Nature² Express.
3. Turn OFF the pool pump. **Your pump/filter system is operated under pressure. The pressure must be released before you begin work. Please see your pump/filter owner's manual for further instructions.**
4. Close any valves. If your pool filtration equipment is below the water level of the pool, you will either need to close the return valve or use winterizing plugs at the skimmer and return fittings to prevent excessive water loss. Contact your authorized Nature² dealer or Zodiac Customer Service at 800-822-7933 for more information.

For Aboveground Pools

Aboveground pools are often plumbed with flexible or corrugated pipe. These systems require use of the rigid PVC adapter included with Nature² Express for aboveground pools. The adapter fits most filtration systems.

- Disconnect the return hose and fitting from the filter.
- Wrap tape around threads of Nature² PVC adapter.
- Thread adapter into the outlet port in the filter.

5. Choose the clamp assembly, (1-1/2" or 2") that fits your return line (Nature² Express for aboveground pools comes with the 1-1/2" clamp assembly only).
6. Apply a small bead of silicone lubricant around the saddle clamp gasket.

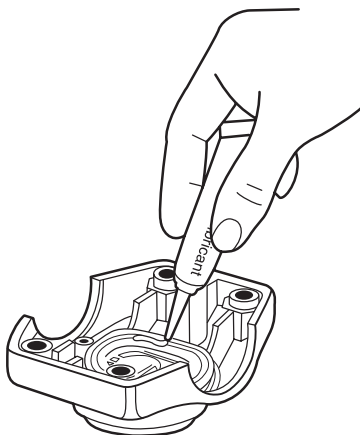

7. **Install your Nature² Express on schedule 40 PVC pipe only. Failure to heed this warning can result in equipment failure.** Position the clamp assembly on the pipe, with the arrow pointing in the direction of the flow of water and hand tighten the nuts and bolts. Tighten nuts an additional 1/4 turn using a wrench or socket. Do not over-tighten.

Note: The 2 halves of the 1-1/2" clamp assembly will not touch when properly assembled. A gap of roughly 1/16" is normal.

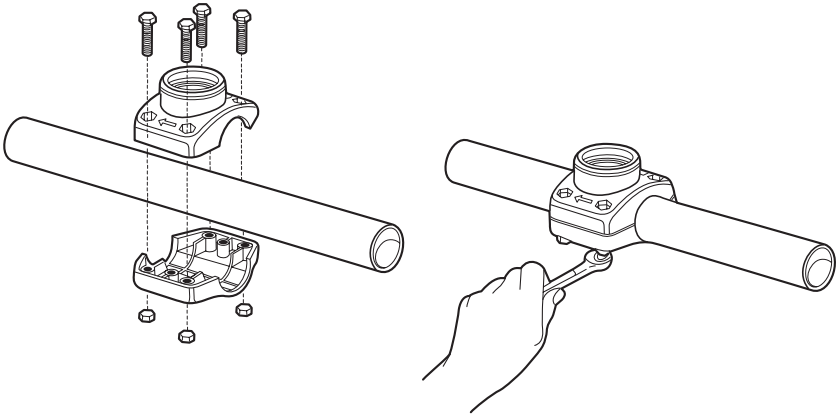

8. Insert the hole saw into a drill. Using the hole in the top half of the clamp assembly as a guide, cut a hole in the pipe.

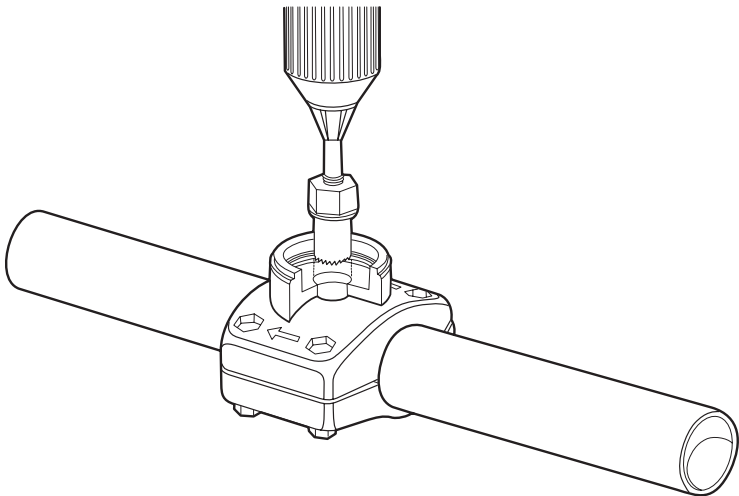

9. Insert the flow diverter into the clamp assembly and snap it into place. Snap the outer housing onto the clamp assembly.

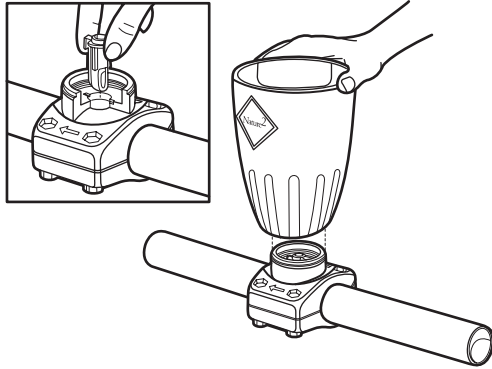

10. Spread silicone around the o-ring just above cartridge threads.
11. Thread the Nature² Express cartridge into the clamp assembly. Set the date reminder.

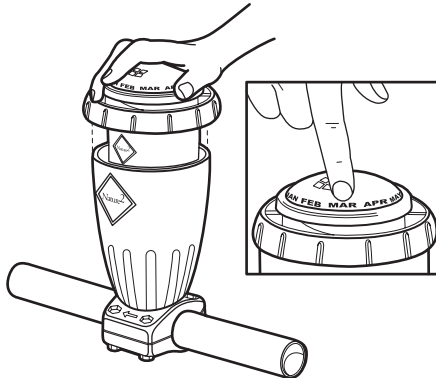

12. Open any valves that you closed and turn on your pool pump to verify that there are no leaks. The small pellets inside the cartridge dome provide evidence of water flow through your Nature² Express.

If a leak is present: turn off pump, close valves, and remove Nature² Express and assembly. Remove any PVC burrs, replace clamp assembly without over-tightening, and re-install cartridge.

13. Refer to your Nature² Cartridge Owner's Manual for cartridge start up procedures.

Operation and Maintenance

Filtration and Circulation

Follow the manufacturer's directions for keeping the circulating pump in good working order and operate it at least six hours a day. Consult your Nature² dealer for optimum run times.

Check pool filter periodically and clean as recommended by the manufacturer.

Replacing The Cartridge

Use the month indicator ring on the top of the unit to identify the date on which the cartridge should be replaced. A Nature² Express cartridge lasts for six months.

To replace the cartridge:

1. Shut off your pool's pump and filter.
2. Close any valves between the filter and pool to prevent draining the pool.
3. Unscrew and remove the old cartridge.
4. Screw the new cartridge into housing and clamp assembly.
5. Rotate the install/replace ring located on the top of the cartridge to the appropriate month.
6. Open any valves that were closed to isolate the Nature² Express.
7. Restart your pool's pump. Check for leaks and fix any leaking fittings.
8. Follow the start up procedures in the Nature² Express Cartridge Owner's Manual.

Winterizing

As part of the pool winterizing process, if you close your pool, remove the Nature² Express cartridge and discard it in the household trash. Snap the winterizing cap on the outer housing to keep out debris.

Install a new Nature² Express cartridge when you re-open your swimming pool. Refer to your Nature² Cartridge Owner's Manual for cartridge start up procedures.

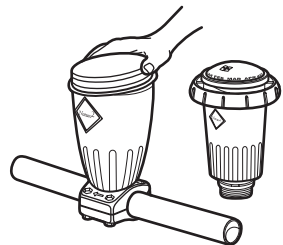

Troubleshooting

Use the guide below to correct common pool issues. For further assistance, consult your Nature² dealer or call us at 1-800-822-7933.

Problem	What to look for:	Treatment
No flow to Nature ² Express.	Dirty filter (one indication: pressure is 8-10 psi higher than normal).	Clean or backwash filter so operating pressure is always within 7 psi of a new filter.
Leaking around vessel.	Dripping from clamp area.	<ol style="list-style-type: none">1. Re-lube gasket and cartridge o-ring.2. Make sure nuts & bolts are tightened evenly and not over-tightened.

Nature² Express Limited Warranty

The limited warranties contained within this document are the only warranties given with your Nature² Express and supercede any prior warranties. **All other warranties, expressed or implied, including the implied warranty of merchantability or the implied warranty of fitness for a particular purpose are hereby disclaimed.** Our sole obligation under this warranty, and the purchaser's sole remedy, is limited to repair or replacement of the Nature² Express housing, or one of its parts. The Nature² warranty applies to the original owner only.

THE LIMITED WARRANTIES OF THE NATURE² EXPRESS HOUSING / CLAMP ASSEMBLY:

The Nature² Express housing you have purchased is warranted to be free of defects and materials and workmanship for a period of one year from the date of purchase.

EXCLUSIONS FROM WARRANTY

Nature² Express is designed for use on in-ground and aboveground pools from 5,000 to 25,000 gallons. If the unit is used in any other application, the warranty is void, and the purchaser and/or pool owner releases the manufacturer from any and all claims related to the use of the Nature² Express.

This warranty does not cover problems arising in whole or in part from purchaser's negligence, misuse or abuse, improper maintenance or storage, accident, improper installation, improper application, failure to follow all appropriate safety precautions, acts of God, abnormal weather conditions, damage from plants or animals, and improper use of chemicals.

This warranty specifically excludes all incidental or consequential damages, except where state law requires them to be paid. This warranty gives you specific rights. You may have other rights that vary from state to state.

TO SUBMIT A CLAIM

Report claims to Zodiac Pool Systems, Inc. by calling 1-800-822-7933. Only the original purchaser may submit a claim under this limited warranty. All claims must be accompanied by an original purchase receipt.



Zodiac Pool Systems, Inc.
2620 Commerce Way
Vista, CA 92081
Tel: 800-822-7933
Fax: 877-327-1403
www.zodiacpoolcare.com