

Jandy® Pro Series Pumps

Model FHPM

WARNING

FOR YOUR SAFETY - This product must be installed and serviced by a contractor who is licensed and qualified in pool equipment by the jurisdiction in which the product will be installed where such state or local requirements exist. The maintainer must be a professional with sufficient experience in pool equipment installation and maintenance so that all of the instructions in this manual can be followed exactly. Before installing this product, read and follow all warning notices and instructions that accompany this product. Failure to follow warning notices and instructions may result in property damage, personal injury, or death. Improper installation and/or operation will void the warranty.



Improper installation and/or operation can create unwanted electrical hazard which can cause serious injury, property damage, or death.

ATTENTION INSTALLER - This manual contains important information about the installation, operation and safe use of this product. This information should be given to the owner/operator of this equipment.

Table of Contents

Section 1. Important Safety Instructions	3	Section 5. Service and Maintenance.....	11
1.1 Safety Instructions.....	3	5.1 Routine Maintenance	11
1.2 Pool Pump Suction Entrapment Prevention Guidelines	5	5.2 Winterizing the Pump	12
Section 2. General Description	6	Section 6. Troubleshooting	12
2.1 Introduction.....	6	6.1 Troubleshooting.....	13
2.2 Description	6	Section 7. Product Specifications and Technical Data	14
Section 3. Installation.....	6	7.1 Replacement Parts List	14
3.1 Plumbing	6	7.2 FHP Exploded View.....	15
3.2 Electrical Installation.....	9	7.3 Performance Curves	15
3.3 Pressure Testing.....	11	7.4 Physical and Operational Specifications	16
Section 4. Operation.....	11		
4.1 Start-up.....	11		

EQUIPMENT INFORMATION RECORD

DATE OF INSTALLATION _____

INSTALLER INFORMATION _____

INITIAL PRESSURE GAUGE READING (WITH CLEAR FILTER) _____

PUMP MODEL _____

HORSEPOWER _____

NOTES:

Section 1. Important Safety Instructions

READ AND FOLLOW ALL INSTRUCTIONS

1.1 Safety Instructions

All electrical work must be performed by a licensed electrician and conform to all national, state, and local codes. When installing and using this electrical equipment, basic safety precautions should always be followed, including the following:

WARNING

RISK OF SUCTION ENTRAPMENT HAZARD, WHICH, IF NOT AVOIDED, CAN RESULT IN SERIOUS INJURY OR DEATH. Do not block pump suction as this can cause severe injury or death. Do not use this pump for wading pools, shallow pools or spas containing bottom drains, unless the pump is connected to at least two functioning suction outlets. Suction outlet (drain) assemblies and covers must be certified to the latest published version of ANSI®/ASME® A112.19.8, or its successor standard, ANSI/APSP-16.

WARNING

To reduce the risk of injury, do not permit children to use this product.

WARNING

To reduce the risk of property damage or injury, do not attempt to change the backwash (multiport, slide, or full flow) valve position with the pump running.

WARNING

Jandy Pro Series pumps are powered by a high voltage electric motor and must be installed by a licensed or certified electrician or a qualified swimming pool service technician.

WARNING

RISK OF ELECTRIC SHOCK, FIRE, PERSONAL INJURY, OR DEATH. Connect only to a branch circuit that is protected by a ground-fault circuit-interrupter (GFCI). Contact a qualified electrician if you cannot verify that the circuit is protected by a GFCI. A GFCI should be provided by the installer and should be tested on a routine basis. To test the GFCI, push the test button. The GFCI should interrupt power. Push the reset button. Power should be restored. If the GFCI fails to operate in this manner, the GFCI is defective. If the GFCI interrupts power to the pump without the test button being pushed, a ground current is flowing, indicating the possibility of electrical shock. Do not use the pump. Disconnect the pump and have the problem corrected by a qualified service representative before using.

Due to the potential risk of fire, electric shock, or injuries to persons, Jandy Pro Series Pumps must be installed in accordance with the National Electrical Code® (NEC®), all local electrical and safety codes, and the Occupational Safety and Health Act (OSHA®). Copies of the NEC may be ordered from the National Fire Protection Association® (NFPA®) online at www.nfpa.org or call 617-770-3000, or contact your local government inspection agency.

WARNING

Incorrectly installed equipment may fail, causing severe injury or property damage.

WARNING

- Do not connect the system to an unregulated city water system or other external source of pressurized water producing pressures greater than 35 PSI.
- Trapped air in system can cause the filter lid to be blown off, which can result in death, serious personal injury, or property damage. Be sure all air is out of the system before operating.

 WARNING

To minimize the risk of severe injury or death the filter and/or pump should not be subjected to the piping system pressurization test.

Local codes may require the pool piping system to be subjected to a pressure test. These requirements are generally not intended to apply to the pool equipment such as filters or pumps.

Zodiac® pool equipment is pressure tested at the factory.

However, if the WARNING cannot be followed and pressure testing of the piping system must include the filter and/or pump, **BE SURE TO COMPLY WITH THE FOLLOWING SAFETY INSTRUCTIONS:**

- Check all clamps, bolts, lids, lock rings and system accessories to ensure they are properly installed and secured before testing.
- RELEASE ALL AIR in the system before testing.
- Water pressure for test must NOT EXCEED 35 PSI.
- Water temperature for test must NOT EXCEED 100°F (38°C).
- Limit test to 24 hours. After test, visually check system to be sure it is ready for operation.

NOTICE: These parameters apply to Zodiac equipment only. For non-Zodiac equipment, consult equipment manufacturer.

 WARNING

Chemical spills and fumes can weaken pool/spa equipment. Corrosion can cause filters and other equipment to fail, resulting in severe injury or property damage. Do not store pool chemicals near your equipment.

 CAUTION

Do not start pump dry! Running the pump dry for any length of time will cause severe damage and will void the warranty.

 CAUTION

This pump is for use with permanently installed pools and may also be used with hot tubs and spas if so marked. Do not use with storable pools. A permanently installed pool is constructed in or on the ground or in a building such that it cannot be readily disassembled for storage. A storable pool is constructed so that it may be readily disassembled for storage and reassembled to its original integrity.

 CAUTION

Do not install within an outdoor enclosure or beneath the skirt of a hot tub or portable spa. The pump requires adequate ventilation to maintain air temperature at less than the maximum ambient temperature rating listed on the motor rating plate.

SAVE THESE INSTRUCTIONS

1.2 Pool Pump Suction Entrapment Prevention Guidelines

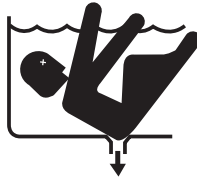

WARNING

SUCTION HAZARD. Can cause serious injury or death. Do not use this pump for wading pools, shallow pools or spas containing bottom drains, unless the pump is connected to at least two (2) functioning suction outlets.

WARNING

Pump suction is hazardous and can trap and drown or disembowel bathers. Do not use or operate swimming pools, spa, or hot tubs if a suction outlet cover is missing, broken, or loose. The following guidelines provide information for pump installation that minimizes the risk of injury to users of pools, spas, and hot tubs:

Entrapment Protection - The pump suction system must provide protection against the hazards of suction entrapment.

Suction Outlet Covers - All suction outlets must have correctly installed, screw-fastened covers in place. All suction outlet (drain) assemblies and their covers must be properly maintained. Suction outlets (drain) assemblies and their covers must be listed/certified to the latest version of ANSI®/ASME® A112.19.8 or its successor standard, ANSI/APSP-16. They must be replaced if cracked, broken, or missing.

Number of Suction Outlets Per Pump - Provide at least two (2) hydraulically-balanced main drains, with covers, as suction outlets for each circulating pump suction line. The centers of the main drains (suction outlets) on any one (1) suction line must be at least three (3) feet apart, center to center. See Figure 1.

The system **must** be built to include at least two (2) suction outlets (drains) connected to the pump whenever the pump is running. However, if two (2) main drains run into a single suction line, the single suction line may be equipped with a valve that will shut off both main drains from the pump. The system shall be constructed such that it shall not allow for separate or independent shutoff or isolation of each drain. See Figure 1.

More than one (1) pump can be connected to a single suction line as long as the requirements above are met.

Water Velocity - The maximum water velocity through the suction outlet assembly and its cover for any suction outlet must not exceed the suction fitting assembly and its cover's maximum design flow rate. The suction outlet (drain) assembly and its cover must comply with the latest version of ANSI/ASME A112.19.8, the standard for Suction Fittings For Use in Swimming Pools, Wading Pools, Spas, and Hot Tubs, or its successor standard, ANSI/APSP-16.

If 100% of the pump's flow comes from the main drain system, the maximum water velocity in the pump suction hydraulic system must be six (6) feet per second or less, even if one (1) main drain (suction outlet) is completely blocked. The flow through the remaining main drain(s) must comply with the latest version of ANSI/ASME A112.19.8 or its successor standard, ANSI/APSP-16, the standard for Suction Fittings For Use in Swimming Pools, Wading Pools, Spas, and Hot Tubs.

Testing and Certification - Suction outlet assemblies and their covers must have been tested by a nationally recognized testing laboratory and found to comply with the latest version of ANSI/ASME A112.19.8 or its successor standard, ANSI/APSP-16, the standard for Suction Fittings For Use in Swimming Pools, Wading Pools, Spas, and Hot Tubs.

Fittings - Fittings restrict flow; for best efficiency use fewest possible fittings (but at least two (2) suction outlets).

Avoid fittings which could cause an air trap.

Pool cleaner suction fittings must conform to applicable International Association of Plumbing and Mechanical Officials (IAPMO) standards.

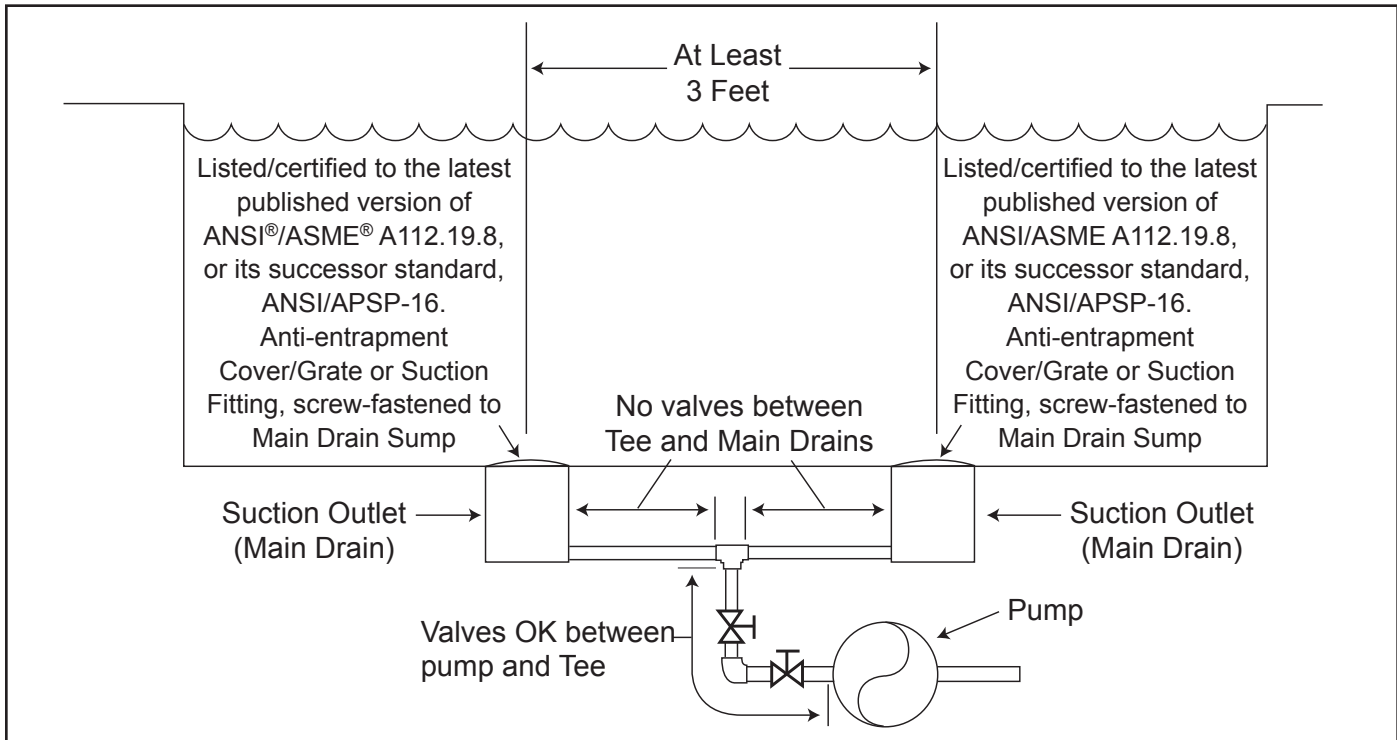

Figure 1. Number of Suction Outlets Per Pump

Section 2. General Description

2.1 Introduction

This manual contains information for the proper installation, operation, and maintenance of Jandy Pro Series FloPro (FHP) Series Pumps, Model FHPM. Procedures in this manual must be followed exactly. To obtain additional copies of this manual, contact Zodiac Pool Systems LLC at 1.800.822.7933. For address information, see the back cover of this manual.

2.2 Description

Jandy® Pro Series FHP Pumps are designed to meet the needs of today's more hydraulically demanding pool equipment. The pump housing, backplate, diffuser, impeller, and hair-and-lint pot (pump debris filter basket) are all made from high quality thermoplastic materials. These materials were chosen for their strength and corrosion resistance.

The pump is driven by an electric motor directly attached to the pump impeller. As the electric motor turns, it causes the impeller to turn, which forces water to flow through the pump. The water flows through the pump inlet and then into the filter basket. The basket assembly pre-strains/traps large particles. The water then enters the center of the pump housing, flows through the impeller into the diffuser, and then flows out the pump discharge port.

Section 3. Installation

3.1 Plumbing

3.1.1 Preparation

1. Upon receipt of the pump, check the carton for damage. Open the carton and check the pump for concealed damage, such as cracks, dents, or a bent base. If you find damage, contact the shipper or the distributor where the pump was purchased.
2. Inspect the contents of the carton and verify that all parts are included. See *Section 7.1, Replacement Parts List*.

3.1.2 Pump Location

⚠ WARNING

To Reduce the Risk of Fire, install pool equipment in an area where leaves or other debris will not collect on or around the equipment. Keep surrounding area clear of all debris such as paper, leaves, pine-needles and other combustible materials.

1. Zodiac Pool Systems LLC recommends installing the pump within 1 foot above water level. The pump should not be elevated more than a few feet above the water level of the pool. A check valve is recommended on the suction line to the pump.

NOTE Better self-priming will be achieved if the pump is installed as close as possible to the water level of the pool.

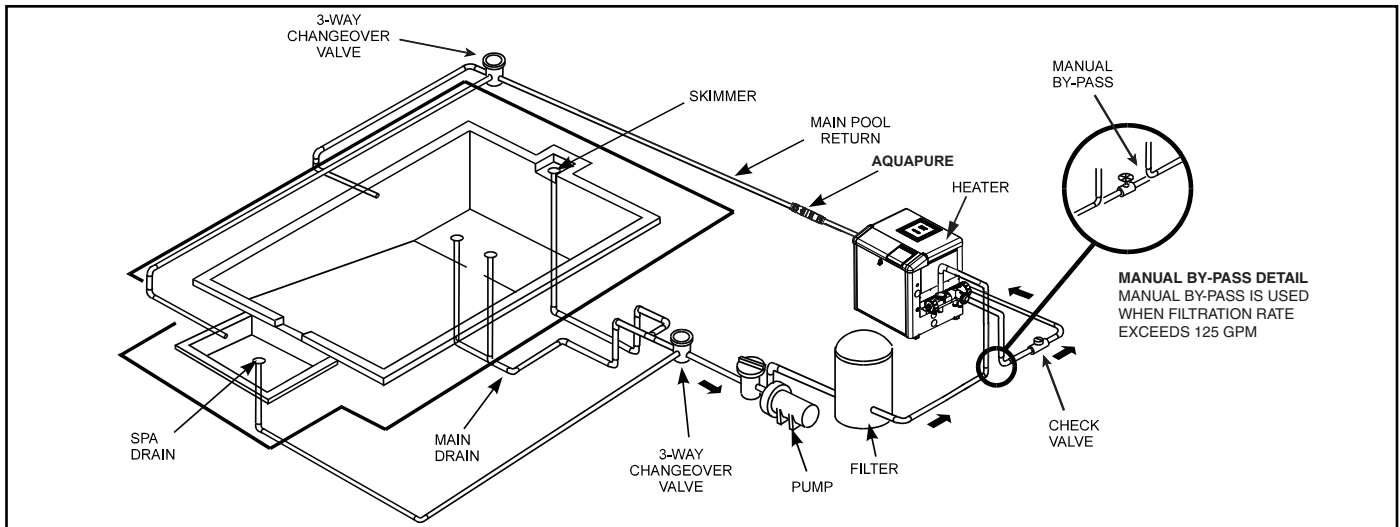

Figure 2. Typical Piping Installation

- If the pump is located below water level, isolation valves **must** be installed on both the suction and return lines to prevent the back flow of pool water during any routine or required servicing.

⚠ WARNING

Some Safety Vacuum Release System (SVRS) devices are not compatible with installation of check valves. If the pool has an SVRS device, be sure to confirm that it will continue to safely operate when any check valves are installed.

- Install the pump such that any disconnecting means and/or junction boxes for power connection are within sight of the pump and at least five (5) feet horizontally from the edge of the pool and/or spa. Choose a location that will minimize turns in the piping.

NOTE In Canada, the minimum distance maintained from the edge of the pool and/or spa as noted above must be 3 meters (10 feet), as required by the Canadian Electrical Code (CEC, CSA C22.1).

- The pump should be installed on a firm, solid, and level surface to avoid risk of settlement. Do not use sand to level the pump as sand will wash away. Check local building codes for any additional requirements (Ex. Equipment pads in Florida must be concrete and equipment must be secured to the pad.)

NOTE Zodiac Pool Systems LLC recommends bolting the pump directly to the foundation.

- The pump foundation must have adequate drainage to prevent the motor from getting wet. The pump needs to be protected from the rain and sun.
- Proper ventilation is required for the pump to operate normally. All motors generate heat that must be removed by providing proper ventilation.

- Provide access for future service by leaving a clear area around the pump. Allow plenty of space above the pump to remove the lid and basket for cleaning.
- If the equipment is under cover, provide adequate lighting.

3.1.3 Replacement of Existing Pump

Jandy Pro Series FHP pumps can easily replace several other pumps: the Hayward® Super Pump®, Hayward Super II, Pentair® SuperFlo®, Pentair® WhisperFlo®, Jandy Pro Series®, PlusHP (PHP), Jandy Pro Series MaxHP (MHP), Sta-Rite® Dura-Glas®, Sta-Rite Dura-Glas II, Sta-Rite Dyna-Glas®, Sta-Rite Max-E-Glas®, Sta-Rite Max-E-Pro®, and Sta-Rite SuperMax®.

To replace the Pentair WhisperFlo, Jandy Pro Series PHP, or Jandy Pro Series MHP, use the FHP's adjustable base. The FHP base (and its spacers) increase the total height of the pump and the height of the suction side of the pump. See Table 1 and Figure 3.

Table 1. FHP Dimensions

Base Configuration	Suction Side Height	Pump Height
1. Pump without Base	7 ¾" (197 mm)	12 ¾" (44 mm)
2. Pump with Base	9" (229 mm)	14" (356 mm)
3. Pump with Base and Spacers	9 ¼" (235 mm)	14 ¼" (362 mm)
4. Pump with Small + Large Base	10 ⅞" (276 mm)	15 ⅞" (403 mm)

3.1.3.1 Install Spacers into Small Base

- Using a hand cutter tool, cut the plastic bars connecting the top and bottom sets of spacers, as shown in Figure 4.
- Push the two (2) top spacers and two (2) bottom spacers out of the base.

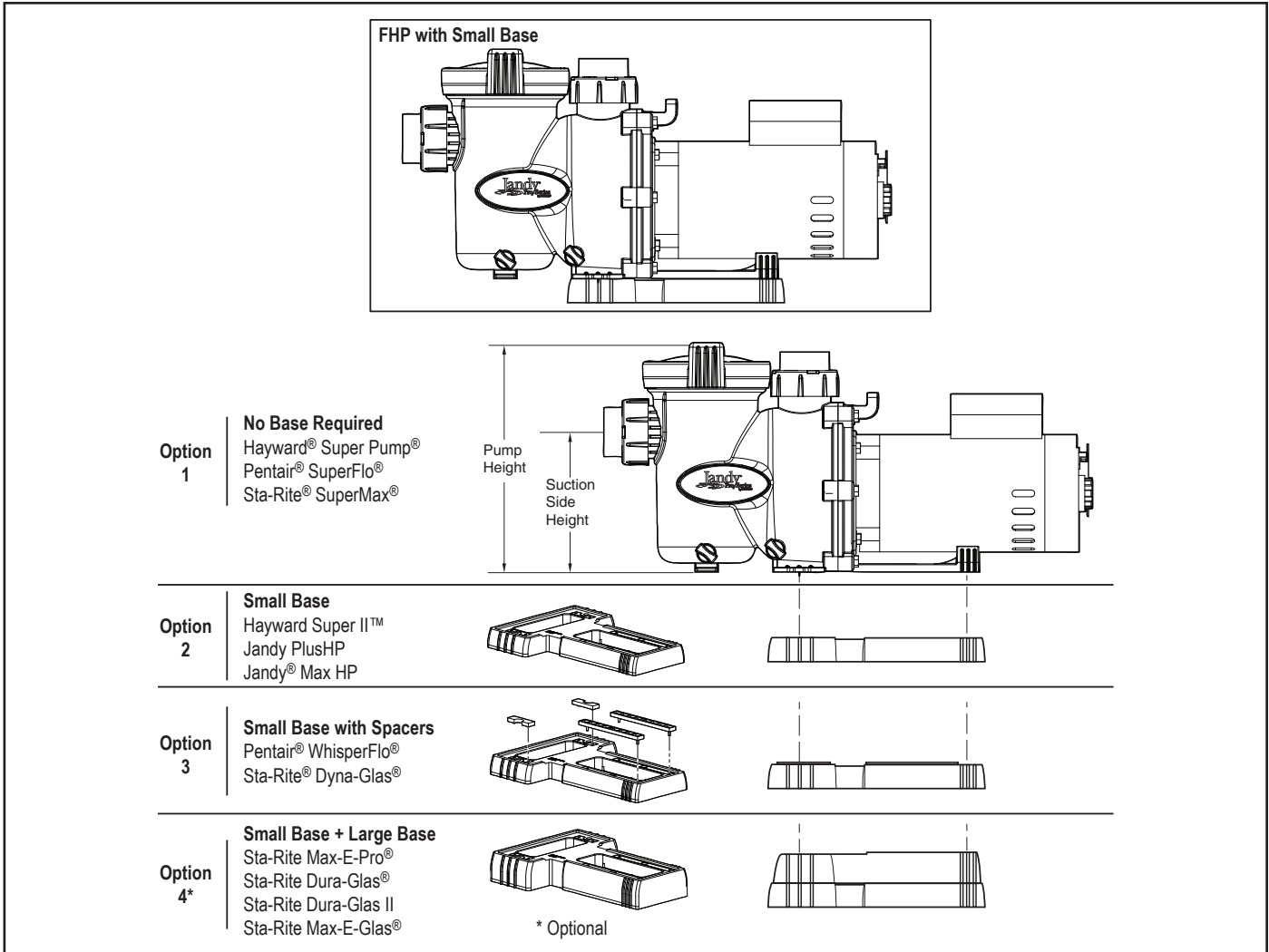

Figure 3. FHP Pump and Base Options

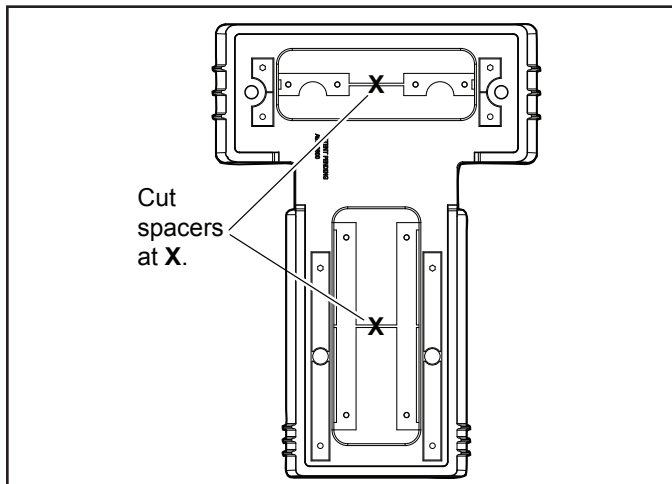

Figure 4. Cut Sets of Spacers Out of Base

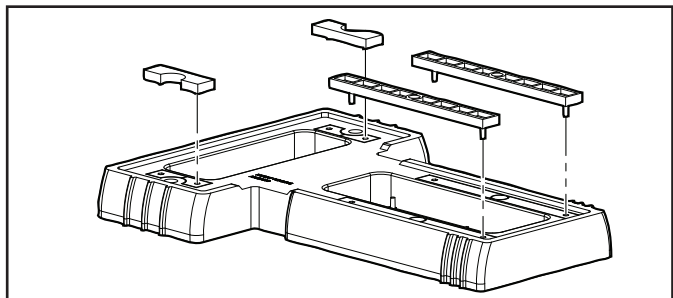

Figure 5. Snap Spacers into Place

Hayward® and Super Pump® are registered trademarks of Hayward Industries, Inc.
 Pentair® is a registered trademark of Pentair, Inc.
 SuperFlo® and WhisperFlo® are registered trademarks of Pentair Water Pool and Spa, Inc.

- Align the pins in the four (4) spacers with the holes in the base and snap the spacers into place, as shown in Figure 5.

3.1.4 Pipe Sizing

3.1.4.1 Suction Pipe

When the pump is located up to 50 feet from the pool, the recommended Schedule 40 minimum pipe size for the suction side of the pump is 1½" for .75 HP and 2" for 1 to 2 HP. For 2.5 HP pumps, the recommended pipe size is 2½".

3.1.4.2 Discharge Pipe

When the pump is located up to 50 feet from the pool, the recommended Schedule 40 minimum pipe size for the discharge side of the pump is 1½" for .75 HP and 2" for 1 to 2 HP. For 2.5 HP pumps, the recommended pipe size is 2½".

NOTE All pipe sizes (Schedule 40) are able to withstand the pressures the pump will deliver, but not necessarily the flow. If the pipe is too small for the pump, or if the pump is elevated above water, the maximum gallons per minute (GPM) may not be delivered. If this happens, the pump will develop an air pocket (cavitation) that will make noise, and the life of the pump may be shortened.

3.1.4.3 Installation Recommendations

- If the pump is located below water level, isolation valves **must** be installed on both sides of the pump to prevent the back flow of pool water during any routine or required servicing.
- To help prevent difficulty in priming, install the suction pipe without high points, which can trap air. (High points are inverted ‘U’s above the inlet of a pump. In plumbing, they are commonly referred to as airlocks.) For installations of equipment up to 100 feet from the water, refer to the pipe sizing chart in Table 2. For installations of equipment more than 100 feet from the water, the recommended pipe size must be increased to the next size.

Table 2. Pipe Sizing Chart for Schedule 40 PVC

Pipe Size	Maximum Flow Suction (6 feet per second)	Maximum Flow Discharge (8 feet per second)
1½"	37 GPM (140 LPM)	50 GPM (189 LPM)
2"	62 GPM (235 LPM)	85 GPM (322 LPM)
2½"	88 GPM (333 LPM)	120 GPM (454 LPM)

- FHP Pumps come equipped with unions on both the suction and discharge ports. This feature simplifies installation and service, and it eliminates the possibility of leaks at threaded adapters.

- The FHP Pump must be connected to at least two (2) main drains (suction outlets) for each pool pump suction line. Each drain (suction outlet) assembly must be provided with covers and must be listed or certified to the latest published version of ANSI®/ASME® A112.19.8, or its successor standard, ANSI/APSP-16. The suction outlets of the main drains must be at least 3 feet apart or at different planes. The suction outlets can be a drain and skimmer, two (2) drains, two (2) skimmers, or a skimmer with an equalizer line installed. For additional details and guidelines, refer to ANSI/APSP 7, the standard for *Suction Entrapment Avoidance in Swimming Pools, Wading Pools, Spas, Hot Tubs, and Catch Basins*. Check the local codes for proper installation requirements. Applicable local codes will take precedence over other codes.

NOTE To prevent entrapment, the system must be built so that it cannot operate with the pump drawing water from only one (1) main drain. At least two (2) main drains **must** be connected to the pump when it is in operation. However, if two (2) main drains run into a single suction line, the single suction line may be equipped with a valve that will shut off both main drains from the pump.

- The piping must be well supported and not forced together in places where constant stress will be experienced.
- Always use properly sized valves. Jandy Pro Series Diverter Valves and Ball Valves typically have the best flow capabilities.
- Use the fewest fittings possible. Every additional fitting has the effect of moving the equipment farther away from the water.

NOTE If more than 10 suction fittings are needed, the pipe size must be increased.

- Every new installation must be pressure tested according to local codes. See *Section 3.3, Pressure Testing*.

3.2 Electrical Installation

3.2.1 Voltage Checks

The correct voltage, as specified on the pump data plate, is necessary for proper performance and long motor life. The incorrect voltage will decrease the pump’s ability to perform and can cause overheating, reduce the motor life, and result in higher electric bills.

It is the responsibility of the electrical installer to provide data plate operating voltage to the pump by ensuring proper circuit sizes and wire sizes for the specific application.

Table 3. Recommended Minimum Wire Size for FHP Pumps

RECOMMENDED MINIMUM WIRE SIZE (AWG) FOR FHP PUMPS*										
Distance from Sub-Panel			0-50 Feet		50-100 Feet		100-150 Feet		150 Feet-200 Feet	
Model	Inverse - Time Circuit Breaker or Branch Fuse AMPS Class: CC, G, H, J, K, RK, or T		Voltage		Voltage		Voltage		Voltage	
	230 VAC	115 VAC	230 VAC	115 VAC	230 VAC	115 VAC	230 VAC	115 VAC	230 VAC	115 VAC
FHPM 0.75HP	15A	15A	14	12	12	8	10	6	8	6
FHPM 1.0HP	15A	20A	14	10	10	8	8	6	8	4
FHPM 1.5HP	15A	20A	12	10	10	6	8	6	6	4
FHPM 2.0HP	15A	20A	12	8	8	6	6	4	6	3
FHPM 2.5HP	15A	N/A	12	N/A	8	N/A	6	N/A	6	N/A
FHPM 1.0HP-2-Speed	15A	N/A	14	N/A	10	N/A	8	N/A	8	N/A
FHPM 1.5HP-2-Speed	15A	N/A	12	N/A	10	N/A	8	N/A	6	N/A
FHPM 2.0HP-2-Speed	15A	N/A	12	N/A	8	N/A	6	N/A	6	N/A

*Assumes three (3) copper conductors in a buried conduit and 3% maximum voltage loss in branch circuit. All National Electrical Code® (NEC®) and local codes must be followed. Table shows minimum wire size and branch fuse recommendations for a typical installation per NEC.

The National Electrical Code® (NEC®, NFPA-70®) requires all pool pump circuits be protected with a Ground Fault Interrupter (GFCI). Therefore, it is also the responsibility of the electrical installer to ensure that the pump circuit is in compliance with this and all other applicable requirements of the National Electrical Code (NEC) and any other applicable installation codes.

CAUTION

Failure to provide data plate voltage (within 10%) during operation will cause the motor to overheat and void the warranty.

3.2.2 Bonding and Grounding

1. In addition to being properly grounded as described below in Sec. 3.2.3, and in accordance with the requirements of the National Electrical Code® (NEC)®, or in Canada the Canadian Electrical Code (CEC), the pump motor must be bonded to all metal parts of the swimming pool, spa or hot tub structure and to all electrical components and equipment associated with the pool/spa water circulation system.
2. The bonding must be accomplished by using a solid copper conducto, No. 8 AWG or larger. In Canada No. 6 AWG or larger must be used. Bond the motor using the external bonding lug provided on the motor frame.

WARNING

To avoid the risk of property damage, severe personal injury, and/or death, always disconnect the power source before working on a motor or its connected load.

WARNING

To avoid the risk of property damage, severe personal injury, and/or death, make sure that the control switch or time clock is installed in an accessible location so that in the event of an equipment failure or a loose plumbing fitting the equipment can be turned off. This location must not be in the same area as the pool pump, filter, and other equipment.

CAUTION

The pump must be permanently connected to a dedicated electrical circuit. No other equipment, lights, appliances or outlets may be connected to the pump circuit, with the exception of devices that may be required to operate simultaneously with the pump, such as a chlorinating device or heater.

3.2.3 Electrical Wiring

WARNING

To avoid risk of property damage, severe personal injury, or death, always ground before connecting to an electrical power supply.

1. The pump motor must be securely and adequately grounded using the green screw provided. Ground before attempting to connect to an electrical power supply. **Do not ground to a gas supply line.**
2. Wire size must be adequate to minimize a voltage drop during the start-up and operation of the pump. See Table 3 for suggested wire sizes.

3. Insulate all connections carefully to prevent grounding or short-circuits. Provide extra protection for sharp edges on terminals. To prevent wire nuts from loosening, tape them using a suitable, listed (UL, ETL, CSA) electrical insulating tape. For safety, and to prevent entry of contaminants, reinstall all conduit and terminal box covers. **Do not force connections into the conduit box.**
4. To configure the internal wiring of the pump motor for the correct voltage, refer to the diagram on the motor data plate.

3.3 Pressure Testing

WARNING

When pressure testing a system with water, air is often trapped in the system during the filling process. This air will compress when the system is pressurized. Should the system fail, this trapped air can propel debris at a high speed and cause injury. Every effort to remove trapped air must be taken, including opening the bleed valve on the filter and loosening the pump basket lid on the filter pump while filling the pump.

WARNING

Trapped air in system can cause filter lid to be blown off, which can result in death, serious personal injury, or property damage. Be sure all air is properly out of system before operating. **DO NOT USE COMPRESSED AIR TO PRESSURE TEST OR CHECK FOR LEAKS.**

WARNING

Do not pressure test above 35 PSI. Pressure testing must be done by a trained pool professional. Circulation equipment that is not tested properly can fail, which could result in severe injury or property damage.

WARNING

When pressure testing the system with water, it is very important to make sure that the pump basket lid on the filter pump is completely secure.

1. Fill the system with water, being careful to eliminate trapped air.
2. Pressurize the system with water to no more than **35 PSI**.
3. Close the valve to trap pressurized water in the system.
4. Carefully observe the system for leaks and/or pressure decay.

Section 4. Operation

4.1 Start-up

CAUTION

Never run the pump without water. Running the pump “dry” for any length of time can cause severe damage to both the pump and motor and will void the warranty.

If this is a new pool installation, make sure all piping is clear of construction debris and has been properly pressure tested. Check the filter for proper installation, verifying that all connections and clamps are secure according to the manufacturer’s recommendations.

WARNING

To avoid risk of property damage, severe personal injury, or death, verify that all power is turned off before starting this procedure.

1. Release all pressure from the system and open the filter pressure release valve.
2. Take one of the following actions:
 - If the pump is located below the water level of the pool, open the filter pressure release valve to prime the pump with water.
 - If the pump is located above the water level, remove the lid and fill the basket with water before starting the pump.
3. Prior to replacing the lid, check for debris around the lid o-ring seat. Debris around the lid o-ring seat will cause air to leak into the system, and make it difficult to prime the pump.
4. **Hand-tighten** the lid to make an air tight seal. **Do not use any tools to tighten the lid: hand-tighten only.** Ensure that the lid is secure. Make sure all valves are open and the unions are tight.
5. Restore power to the pump and then turn it on.
6. Once all the air has left the filter, close the filter pressure release valve.
7. The pump should prime. The time it takes to prime will depend on the elevation and length of pipe used on the suction supply pipe. See *Section 3.1.3.3, Installation Recommendations* for proper elevation and pipe size.
8. If the pump does not prime and all the instructions to this point have been followed, check for a suction leak. If there is no leak, repeat Steps 2 through 7.
9. For technical assistance, call Zodiac Technical Support at 1.800.822.7933.

Section 5. Service and Maintenance

5.1 Routine Maintenance

WARNING

To avoid the risk of property damage, severe personal injury, and/or death, turn off the pump and switch off the circuit breaker to the pump motor before servicing the pump.

Inspect the pump basket for debris by looking through the clear pump lid. Remove any debris, because as debris accumulates, it will begin to block the flow of water through the pump. Keep the basket clean to improve the performance of the pump.

1. Turn off the power to the pump. If the pump is located below the water level, close the isolation valves on the suction and discharge sides of the pump to prevent backflow of water.
2. Turn the lid's locking ring counter-clockwise until 'START' aligns with the ports. Carefully remove the lid.

CAUTION

A misaligned basket will cause the lid to be improperly seated, allowing an air leak, which could result in pump damage.

3. Lift the basket out of the pump. Dispose of all debris and thoroughly clean the basket, making sure all the holes are open. Using a garden hose, spray the basket from the outside to help clear the holes. Remove any remaining debris by hand.
4. Replace the basket in the pump by aligning the open section of the basket with the inlet pipe. If aligned properly, the basket will drop easily into place. **Do not force it into place.**
5. Remove the lid o-ring and remove debris around the lid o-ring seat, as this will cause air leaks into the system. Clean the lid o-ring and replace it.
6. Replace the lid with locking ring on the pump housing. Align 'START' with the ports and turn the lid's locking ring clockwise until 'LOCKED' aligns with the ports. **Hand-tighten** the lid to make an air tight seal. **Do not use any tools to tighten the lid.**
7. Verify that all valves have been returned to the proper position for normal operation.
8. Open the pressure release valve on the filter, and make sure it is clean and ready for operation.

9. Turn on the power to the pump. Once all the air has been evacuated from the filter, close the filter pressure release valve.

5.2 Winterizing the Pump

CAUTION

The pump **must** be protected when freezing temperatures are expected. Allowing the pump to freeze will cause severe damage and void the warranty.

CAUTION

Do not use antifreeze solutions in the pool, spa, or hot tub systems! Antifreeze is highly toxic and may damage the circulation system. The only exception to this is Propylene Glycol. For more information see your local pool/spa supply store or contact a qualified swimming pool service company.

1. Drain **all** water from the pump, system equipment, and piping.
2. Remove the two (2) drain plugs. Store the drain plugs in a safe location and reinstall them when the cold weather season is over. **Do not lose the o-rings.**
3. Keep the motor covered and dry. Do not cover it with plastic, as this will create condensation and this moisture will damage the pump.

- NOTE** To protect your pump, Zodiac Pool Systems LLC recommends having a qualified service technician or electrician properly disconnect the electrical wiring at the switch or junction box. Once the power is removed, the two (2) unions can be loosened and the pump stored indoors. For safety, and to prevent entry of contaminants, reinstall all conduit and terminal box covers.
4. When the system is reopened for operation, make sure all piping, valves, wiring, and equipment are in accordance with the manufacturer's recommendations. Pay close attention to the filter and electrical connections.
 5. The pump must be primed prior to starting; refer to *Section 4.1, Start-up*.

Section 6. Troubleshooting

Zodiac Pool Systems LLC strongly recommends that you call a qualified service technician to perform any repairs on the pump system. To locate a qualified technician, check your local yellow pages or visit www.zodiacpoolsystems.com and click on "Support."

6.1 Troubleshooting

Symptom	Possible Problem/Solution
The cleaning/circulating system is not operating correctly.	<p>Verify that skimmer baskets, pump basket and other screens are clean. Clean as necessary. If a filter is installed in the system, check the filter and clean as necessary.</p> <p>Check valve positions. Adjust as necessary.</p> <p>NOTE Multiple pieces of equipment operating at one time (for example, waterfalls, spa jets, and surface returns) may affect the cleaning system and prevent it from working properly.</p> <p>Check cleaning system manual to ensure the system is adjusted according to manufacturer's recommendations.</p>
Bubbles present in the pump basket.	<p>Air is in system. Check pool or spa water level to ensure it is at the proper level and air is not being drawn into suction piping. If water is at normal level, turn off pump. Turn the lid's locking ring counter-clockwise until 'START' aligns with ports. Remove lid and check for debris around lid seal seat or improper installation of lid seal, as either of these conditions will cause air leaks in the system. Clean lid seal and lid groove. Note that one (1) side of lid seal has two (2) ribs and the other has one (1). See Figure 2. Place the side with two (2) ribs into lid groove. Replace lid on pump housing. Align 'START' with ports and turn lid's locking ring clockwise until 'LOCKED' aligns with ports. Hand-tighten the lid to make an air tight seal. Do not use any tools to tighten the lid. Turn the pump back on.</p>
Air leaks are still present.	<p>Check the suction side piping union. While the pump is running, try to tighten the union. If this does not stop the air leak, turn off the pump. Loosen both unions and slide the pump out of the way. Remove, clean, and re-install both union o-rings.</p> <p>Reposition the pump next to the piping and secure the union nuts to the pump. With clean union o-rings, hand-tightening of the unions should create a seal. If the unions still do not seal, gently tighten with a large pair of tongue-and-groove pliers.</p> <p>Do not over-tighten.</p>
There is no air in the system, but the pressure is still low.	<p>It is possible that debris is caught in the pump impeller. The pump impeller moves the water, and the vanes in the impeller can become blocked with debris.</p> <ol style="list-style-type: none"> 1. Turn off the pump. Switch off the circuit breaker to the pump motor. 2. Remove the lid and basket. 3. Look inside the pump for any debris. Remove any debris found inside. 4. Replace the basket and lid. 5. Switch on the circuit breaker to the pump motor. 6. Turn on the pump, and see if the problem is solved. 7. If the impeller is still blocked with debris and it is not possible to remove the debris using Steps 2 through 4, the pump will need to be disassembled in order to access the inlet and outlet of the impeller.
There is no debris blocking the impeller and the pressure is still low.	<p>The pump impeller and diffuser are showing signs of normal wear. Have a qualified service technician check the impeller and diffuser and replace as necessary.</p> <p>If the pump is part of a relatively new installation, it could be an electrical problem. Contact a qualified service technician. Have the technician check for loose electrical connections and check the voltage at the pump motor while it is in operation. The voltage must be within 10% of the motor's data plate rating. If the voltage is not within 10%, contact a qualified electrician and/or the local power service provider.</p>
The pump is leaking water between the motor and pump body.	<p>This is caused by a damaged or failed mechanical seal. The pump seal is leaking air. Have a qualified service technician replace the seal.</p>
The pump gets hot and shuts off periodically.	<p>Ensure that there is adequate room around the motor to circulate air and keep motor cool. Have a qualified electrician check for loose connections and check voltage at the pump motor while it is in operation. The voltage must be within 10% of the motor's data plate rating. If voltage is not within 10%, contact a qualified electrician and/or the local power service provider.</p>

Section 7. Product Specifications and Technical Data

7.1 Replacement Parts List

To order or purchase parts for Jandy Pro Series pumps, contact your nearest Zodiac dealer. If the Zodiac dealer cannot supply you with what you need, contact Zodiac technical support at 1.800.822.7933, or send an e-mail message to productsupport@zodiac.com.

Key No.	Description	Model No. (HP)	Order Part No.
1	Single-speed Motor & Hardware, FHP	0.75	R0479310
1	Single-speed Motor & Hardware, FHP	1.0	R0479311
1	Single-speed Motor & Hardware, FHP	1.5	R0479312
1	Single-speed Motor & Hardware, FHP	2.0	R0479313
1	Single-speed Motor & Hardware, FHP	2.5	R0479314
1	2-Speed Motor & Hardware, FHP	1.0	R0479306
1	2-Speed Motor & Hardware, FHP	1.5	R0479307
1	2-Speed Motor & Hardware, FHP	2.0	R0479308
2	Backplate, FHP (Backplate w/Hardware, Backplate O-ring & Mechanical Seal)	All	R0479500
3	Impeller, FHP (Impeller, Screw w/O-ring & Backplate O-ring)	0.75	R0479601
3	Impeller, FHP (Impeller, Screw w/O-ring & Backplate O-ring)	1.0, 1.0-2	R0479602
3	Impeller, FHP (Impeller, Screw w/O-ring & Backplate O-ring)	1.5, 1.5-2	R0479603
3	Impeller, FHP (Impeller, Screw w/O-ring & Backplate O-ring)	2.0, 2.0-2	R0479604
3	Impeller, FHP (Impeller, Screw w/O-ring & Backplate O-ring)	2.5	R0479605
4	Diffuser, FHP (Diffuser w/O-ring, Hardware & Backplate O-ring)	0.75, 1.0, 1.0-2	R0479702
4	Diffuser, FHP (Diffuser w/O-ring, Hardware & Backplate O-ring)	1.5, 1.5-2, 2.0, 2.0-2, 2.5	R0479701
5	Mechanical Seal, Carbon and Ceramic (1 Set)	All	R0479400
6	Pump Body, FHP (Body and Backplate O-ring)	All	R0479800
7	Motor Mounting Foot, FHP	All	R0479900
8	Lid w/Locking Ring, FHP (Lid w/Locking Ring & Lid O-ring)	All	R0480000
9	Pump Debris Filter Basket, FHP	All	R0480100
10	Drain Plug w/ O-ring (Set of 2)	All	R0446000
11	Tail Piece, O-ring & Union Nut (Set of 2)	All	R0327301
12	Lid O-ring, FHP	All	R0480200
13	Backplate O-ring, FHP	All	R0480300
14	Diffuser/Impeller Hardware (Diffuser O-ring, Screws (2), Screw w/O-ring & Backplate O-ring)	All	R0480400
15	Backplate Hardware, FHP (Backplate Hardware & Backplate O-ring)	All	R0480500
16	Motor Hardware Kit	All	R0446700
17	Tailpiece O-ring (Set of 2)	All	R0337601
18	Small Base Spacer	All	R0486700
19	Large Base Spacer (optional)	All	R0546400

7.2 FHP Exploded View

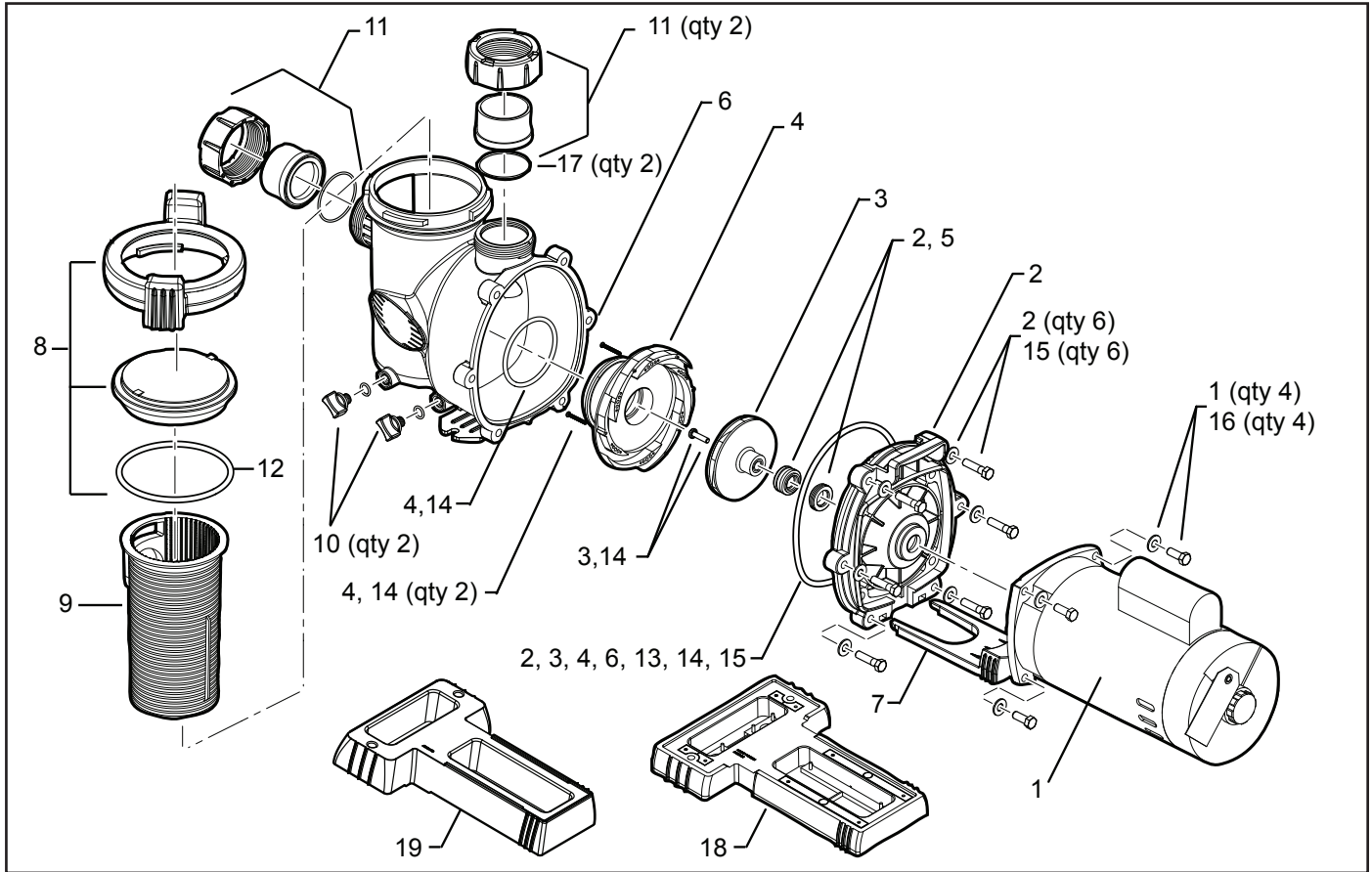

7.3 Performance Curves

Jandy FloPro Series Pumps Max-Rated (FHPM)

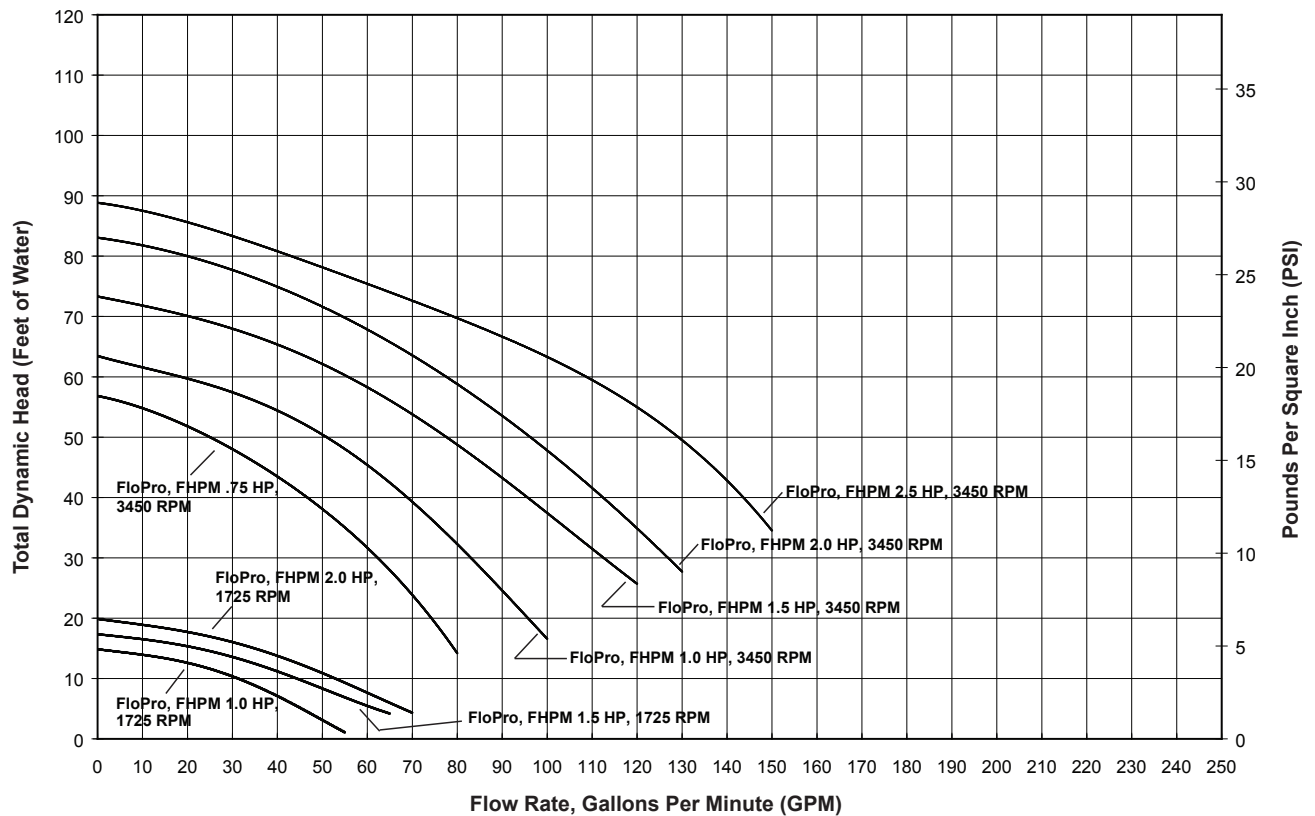

7.4 Physical and Operational Specifications

7.4.1 Specifications

Table 4. FHPM Pump Specifications

Model No.	HP	Voltage	Amps	Pipe Size	Carton Weight	Overall Length 'A'
FHPM .75	0.75	230/115	5.4/10.8	1½-2"	40.6	25 3/16"
FHPM 1.0	1.00	230/115	7.1/14.2	2-2½"	41.2	25 3/16"
FHPM 1.5	1.50	230/115	8.0/16	2-2½"	42.6	25 ½"
FHPM 2.0	2.00	230/115	11.2/22.4	2-2½"	54.6	27 3/16"
FHPM 2.5	2.50	230	11.5	2½-3"	48.6	26 3/16"
FHPM 1.0-2SPD	1.00	230	6.0/2.3	2½-3"	46.5	26 5/16"
FHPM 1.5-2SPD	1.50	230	7.2/3.0	2½-3"	48.0	26 9/16"
FHPM 2.0-2SPD	2.00	230	10.0/3.5	2½-3"	52.9	27 11/16"

7.4.2 Dimensions

Table 1 shows the height of the FHP pump in the four (4) mounting configurations listed below. Figure 3 on page 8 shows drawings of these four (4) configurations.

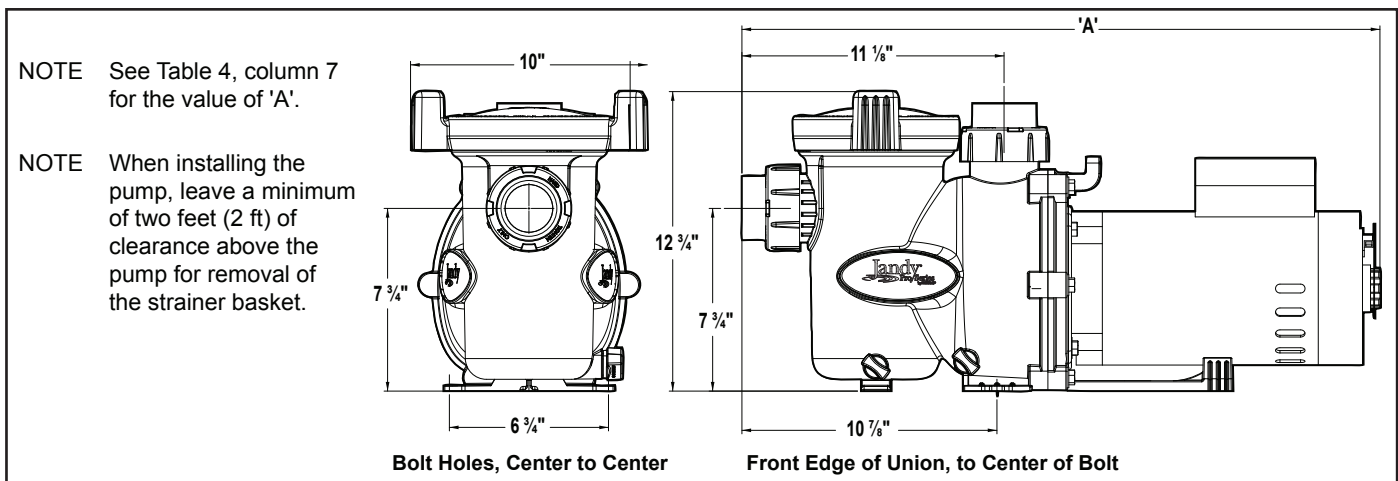

Figure 6. FHP Pump Dimensions (without Base or Spacers)



CONFORMS TO UL STD 1081
CERTIFIED TO CSA STD C22.2 NO 108



Zodiac Pool Systems LLC
2620 Commerce Way, Vista, CA 92081
1.800.822.7933 | www.ZodiacPoolSystems.com

©2017 Zodiac Pool Systems LLC. ZODIAC® is a registered trademark of Zodiac International, S.A.S.U., used under license. All trademarks referenced herein are the property of their respective owners.

H0315300 Rev R