

Model 35

Atmospheric Vacuum Breaker (1/2")



❑ Installation ❑ Maintenance Instructions

Connect the supply piping to the bottom of the WILKINS Model 35 Atmospheric Vacuum Breaker. Connect the outlet of the Vacuum Breaker to the fixture being served as shown in the diagram below.

The extreme bottom of the AVB shall be taken as the critical installation level. Therefore, the highest fixture being served shall be a minimum of 6 inches below the bottom of the AVB.

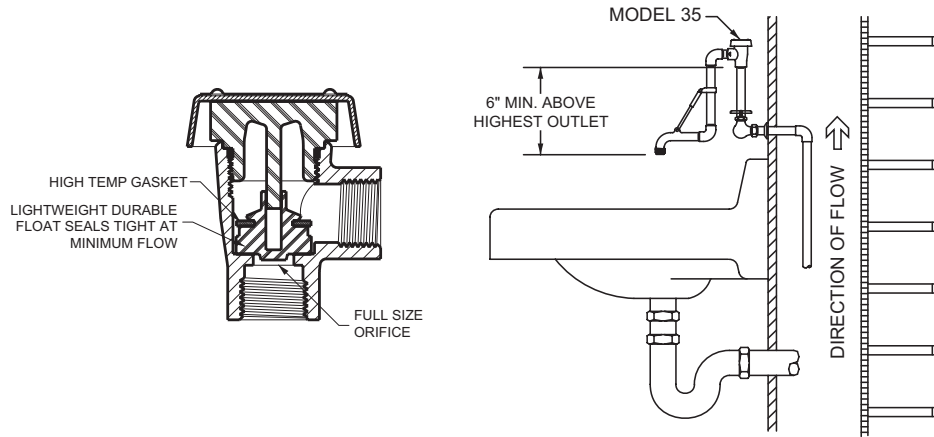

CAUTION: This device should never be used in installations that are under continuous pressure. Therefore, never place a shut-off or check valve downstream of AVB's. This device shall not be installed in a concealed or inaccessible location, nor where the venting water from the device during normal functioning may be deemed objectionable.

WARRANTY: WILKINS Valves are guaranteed against defects of material or workmanship when used for the services recommended. If in any recommended service, a defect develops due to material or workmanship, and the device is returned, freight prepaid, to WILKINS within 12 months from date of purchase, it will be repaired or replaced free of charge. WILKINS' liability shall be limited to our agreement to repair or replace the valve only.

Proposition 65 Warning This product contains chemicals known to the State of California to cause cancer or birth defects or other reproductive harm.

This product is not to be used to convey water for human consumption through cooking or drinking in California or Vermont. California H&S Code §116875, VSA §2470h



WILKINS a ZURN company

1747 Commerce Way, Paso Robles, CA 93446 Phone:805-238-7100 Fax:805-238-5766

Model 35

Atmospheric Vacuum Breaker (1/2")



❑ Installation ❑ Maintenance Instructions

Connect the supply piping to the bottom of the WILKINS Model 35 Atmospheric Vacuum Breaker. Connect the outlet of the Vacuum Breaker to the fixture being served as shown in the diagram below.

The extreme bottom of the AVB shall be taken as the critical installation level. Therefore, the highest fixture being served shall be a minimum of 6 inches below the bottom of the AVB.

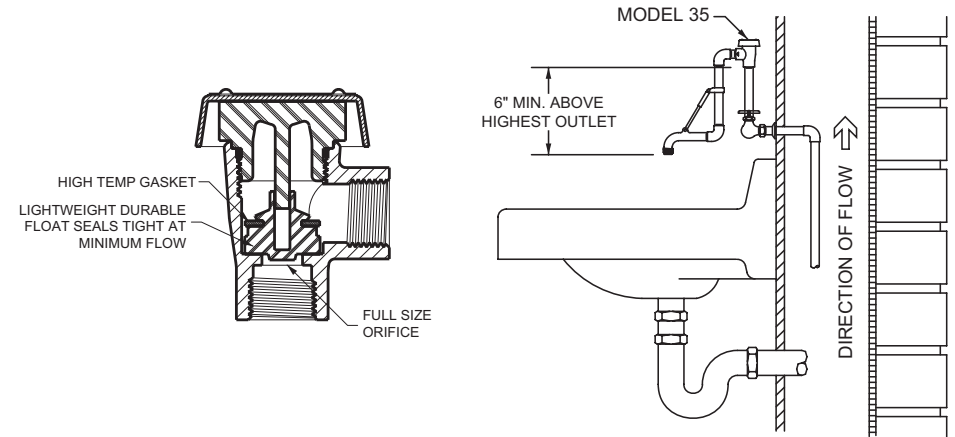

CAUTION: This device should never be used in installations that are under continuous pressure. Therefore, never place a shut-off or check valve downstream of AVB's. This device shall not be installed in a concealed or inaccessible location, nor where the venting water from the device during normal functioning may be deemed objectionable.

WARRANTY: WILKINS Valves are guaranteed against defects of material or workmanship when used for the services recommended. If in any recommended service, a defect develops due to material or workmanship, and the device is returned, freight prepaid, to WILKINS within 12 months from date of purchase, it will be repaired or replaced free of charge. WILKINS' liability shall be limited to our agreement to repair or replace the valve only.

Proposition 65 Warning This product contains chemicals known to the State of California to cause cancer or birth defects or other reproductive harm.

This product is not to be used to convey water for human consumption through cooking or drinking in California or Vermont. California H&S Code §116875, VSA §2470h



WILKINS a ZURN company

1747 Commerce Way, Paso Robles, CA 93446 Phone:805-238-7100 Fax:805-238-5766