

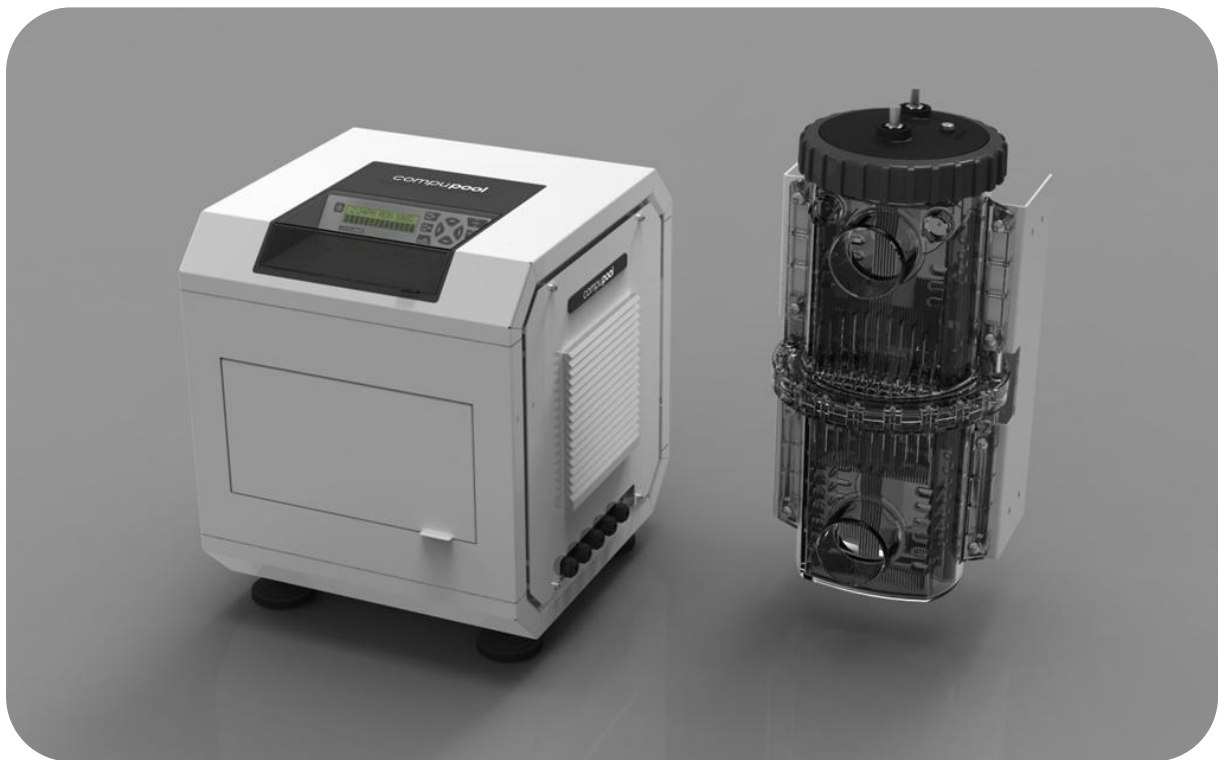

'Technology in Harmony with Nature'

E-Series Commercial
Saltwater Chlorine Generator
Owner's Manual



2012 E-Series Owners Manual AU - V2.docx

1.0 GENERAL PRODUCT SPECIFICATION

1.1 AC Input Power

1.1.1 Single Phase (220-240VAC)

1.2 Agency Approvals

1.2.1 CE - EMC Standards EN61000-3-2.

1.3 Max Chlorine Output (kg/24hrs):

1.3.1 Range: 2.4 – 12 kg/24hrs

E-S100	2.4
E-S150	3.6
E-S200	4.8
E-S300	7.2
E-S400	9.6
E-S500	12.0

1.4 General

1.4.1 For indoor or protected outdoor use.

1.4.2 Optimal Salt Level 3500 ppm / 3.5 g/L.

1.4.3 Caution: Over-purification may be hazardous and will reduce cell life.

1.5 Contact

For assistance please contact the Compu Pool:

Phone Number: +61 (0)7 5596 3773 9:00am - 5:00pm EST

Manufactured by:

Compu Pool Products

3-7 Hilldon Court, Nerang QLD 4211

Phone: +61 (0)7 5596 3773 Fax: +61 (0)7 5596 1951

www.compupool.com.au

2.0 SAFETY INSTRUCTIONS

2.1 IMPORTANT SAFETY INSTRUCTIONS, READ AND FOLLOW ALL INSTRUCTIONS. SAVE ALL INSTRUCTIONS.

- 2.1.1 Follow all aspects of the local and National Electrical Code(s) when installing this device.
- 2.1.2 NOTE: A bonding terminal is located on the metal electrical enclosure of this device. To reduce the risk of electrical shock, this terminal must be connected to the grounding means provided in the electrical supply.
- 2.1.3 WARNING: To reduce the risk of injury, do not permit children, untrained or unauthorised personnel to operate this device. Children should not use spas, hot tubs or pools without permanent adult supervision.
- 2.1.4 WARNING: Maintain water chemistry in accordance the instructions in this manual. Failure to do so will void the warranty.
- 2.1.5 WARNING: Heavy pool (and/or spa) usage, and higher temperatures may require higher chlorine output to maintain a proper level of free available chlorine residuals.
- 2.1.6 WARNING: Installation of electrical wiring should only be performed by a qualified electrician. Failure to do so could result in serious harm and electrocution.
- 2.1.7 If additional chlorine is required due to heavy bather loads, use Sodium Hypochlorite to maintain an appropriate chlorine residual in the water. NOTE: For outdoor pools, chlorine residuals can be protected from destruction by sunlight by addition of stabilizer (cyanuric acid).
- 2.1.8 Maintaining high chlorine and very high salt levels above the recommended range can contribute to corrosion of pool (and/or spa) equipment.
- 2.1.9 Check the expiration date of any water chemistry test kits as test results may be inaccurate if used after that date.



'Technology in Harmony with Nature'

E-Series Commercial Saltwater Chlorine Generator **Owner's Manual**

1.0	GENERAL PRODUCT SPECIFICATION.....	2
2.0	SAFETY INSTRUCTIONS.....	3
3.0	INTRODUCTION.....	5
4.0	GETTING STARTED.....	5
5.0	THE CHEMISTRY INVOLVED.....	6
6.0	WATER CHEMISTRY.....	6
7.0	ADDING SALT TO POOL OR SPA.....	9
8.0	INSTALLATION.....	10
9.0	INSTALLATION CHECKLIST.....	19
10.0	USING THE CONTROL PANEL.....	19
11.0	MAINTENANCE.....	21
12.0	WARRANTY.....	23

3.0 INTRODUCTION

- 3.1.1 Congratulations on the recent purchase of a Compu Pool Products E-Series Commercial Saltwater Chlorine Generator. Please take a moment to read through the entire manual before installing the new unit. The generator must be installed and operated as specified.

4.0 GETTING STARTED

- 4.1.1 **READ THIS FIRST.** As with any electrical device it is very important that the installation and service of this equipment be performed by a qualified person with the skills and experience required to install it safely and correctly. Improper installation or service can result in severe electrical shock to the installer or user of the equipment or pool. Please choose the installer with great care.
- 4.1.2 Maintenance personnel should be made familiar with all aspects of the chlorinator. Improper operation or failure to carry out correct maintenance procedures may cause damage to the unit and void the warranty.

4.2 The E-Series Chlorinator system at a glance.

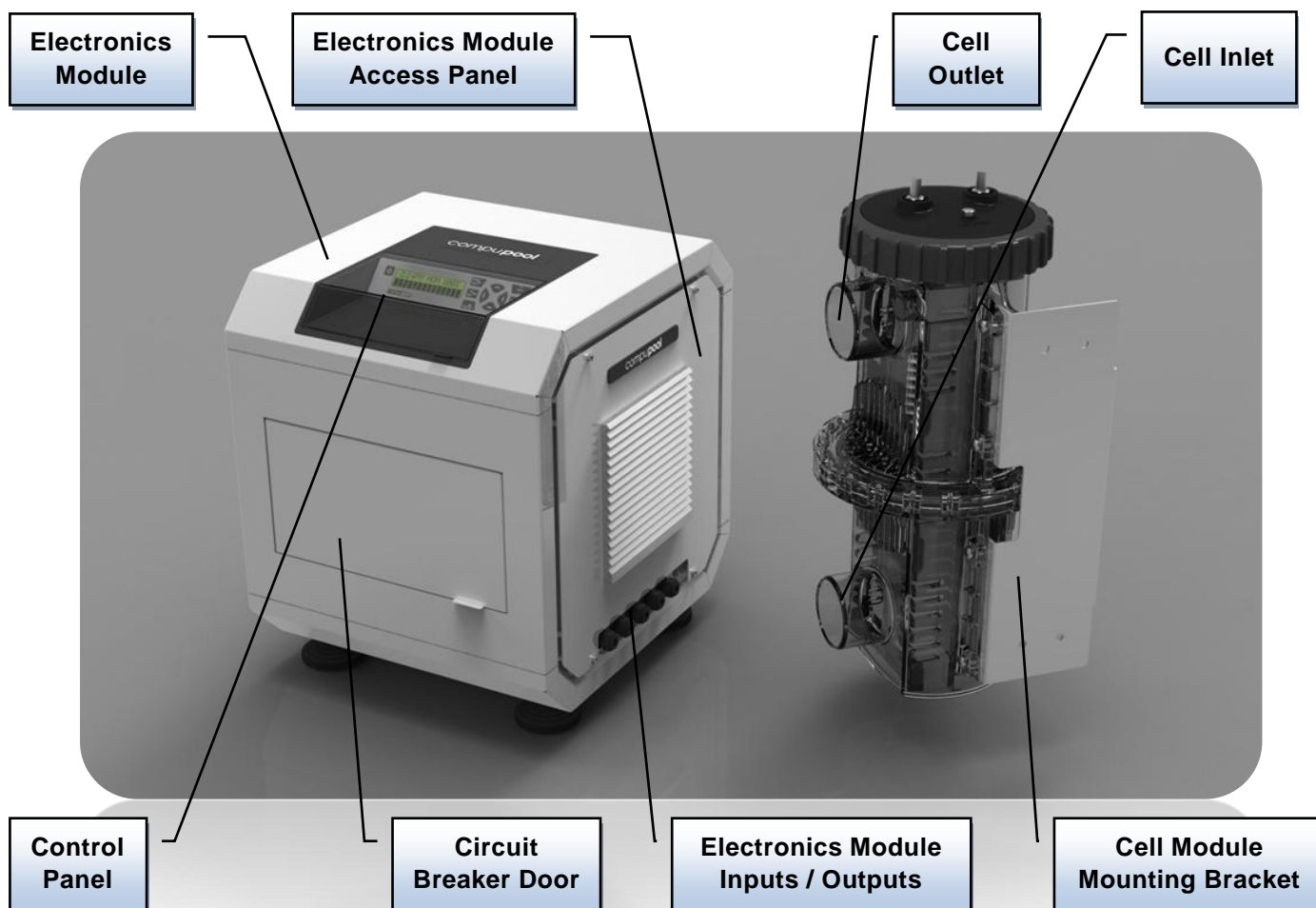

5.0 THE CHEMISTRY INVOLVED

- 5.1.1 The E-Series Commercial Chlorine Generator by electrolysis creates chlorine to sanitize the pool using the salt (NaCl) in the water. A small electric charge is applied across a set of titanium plates inside the Electrolytic Cell(s). This produces Sodium Hypochlorite (NaOCl). In water, Sodium Hypochlorite dissociates into sodium (NA+) and hypochlorite (OCl-) ions.
- 5.1.2 It is the hypochlorite ions that form with the hydrogen (H+) ions (from the water) to form hypochlorous acid (HOCl), which is the active agent that destroys bacteria and algae, and oxidizes organic matter. This form of chlorine works quickly in the pipe, leaving only a mild residual in the pool.

6.0 WATER CHEMISTRY

6.1 WARNING: Prior to turning on the E-Series Chlorine Generator for the first time (including reopening the pool for the new pool season) the water chemistry must be balanced according to the following guidelines.

- 6.1.1 With proper filtration and chemically balanced water the pool should be clear and sparkling. Unbalanced water can result in scaling, corrosion of pump equipment and inefficient operation of the E-Series system.

6.2 Recommended Salt and Pool / Spa Chemistry Readings

	Swimming Pools	Spas
Free Available Chlorine	1.0 – 3.0 ppm	3.0 – 5.0 ppm
pH	7.2 – 7.8	7.2 – 7.8
Total Alkalinity	100 – 120 ppm	100 – 120 ppm
Calcium Hardness	200 – 300 ppm	150 – 200 ppm
Stabilizer (Cyanuric Acid)	30 – 60 ppm	30 – 60 ppm
Total Dissolved Solids	< 1,200 ppm	< 1,200 ppm
Salt Residual	Optimal 3500 ppm	Optimal 3500 ppm

- 6.2.1 **pH Levels.** pH produced by a chlorine generator is close to neutral pH. However, other factors usually cause the pH of the pool water to rise. Therefore, the pH in a pool chlorinated by a chlorine generator tends to stabilize at approximately 7.8. This is within national standards. If the pool pH rises above 7.8, have a pool professional test to see if other factors such as high Calcium Hardness or Total Alkalinity are the cause, and then balance accordingly.

-
- 6.2.2 **Chlorine Stabilizer (Cyanuric Acid).** Chlorine Stabilizer is needed to maintain proper levels of chlorine. Unstable chlorine can be destroyed by the sun's UV radiation within two hours. Chlorine stabilizer must be maintained between 30 – 60 ppm.
 - 6.2.3 **Nitrates and Phosphates.** These chemicals can cause extremely high chlorine demands and will deplete chlorine from the pool. In some cases, they may even lower the chlorine levels to zero. A pool professional can test for Nitrates and Phosphates.
 - 6.2.4 **Metals.** Metals can cause loss of chlorine. Also, metals can stain the pool and tint the water. A pool professional can check for metals and recommend methods of removal.
 - 6.2.5 **Chloramines.** Chloramines should not be present in pool water. When organic materials are not fully oxidized by Free Chlorine, Chloramines are formed. This ties up the Free Chlorine in the pool, and does not allow the chlorine in the pool to disinfect. Chloramines also cloud pool water and burn the eyes. Shock the pool with chlorine to remove Chloramines at the initial startup of the pool.
 - 6.2.6 **Total Dissolved Solids (TDS).** Adding salt to pool water will raise the TDS level. While this does not adversely affect the pool water chemistry or clarity, the pool water professional testing for TDS must be made aware that salt has been added for a chlorinator system. The individual performing the TDS test will then subtract the salinity level to arrive at the correct TDS level.

6.3 Water Chemistry Helpful Hints

- 6.3.1 Proper operation of the chlorine generator can be easily verified by inspecting the Electrolytic Cell. The chlorine being produced will appear as a fog along the plates. However, if the pool remains cloudy, or the chlorine residual tests low, then the chlorine being produced is being lost due to high chlorine demand or improper water conditions. To reduce the chlorine demand, check the pH and Stabilizer (Cyanuric Acid) reading. If tests show correct, then a shock treatment with an oxidizer agent is advised.

6.4 Recommended List

- 6.4.1 Read and keep the manual in a safe place.
- 6.4.2 Increase chlorine production when temperature goes up.
- 6.4.3 Increase chlorine production when number of pool users goes up.
- 6.4.4 Use Stabilizer (Cyanuric Acid) to protect free chlorine in the pool.
- 6.4.5 Decrease chlorine production when temperature goes down.

6.5 Not Recommended List

- 6.5.1 Do not allow fertilizer anywhere near the pool. Fertilizers contain Nitrates or Phosphates which cause severe chlorine demand in pool water.
- 6.5.2 Never use dry acid to adjust pH. A build up of by-products can damage the Electrolytic Cell.
- 6.5.3 Do not add any pool water balancing chemicals (including salt) unless the Chlorinator is turned off.
- 6.5.4 Do not add any chemicals (including salt) to the skimmers (if applicable).
- 6.5.5 Do not let salinity level drop below 3500 ppm.

6.6 Definitions

- 6.6.1 **Algae.** Plant-like organisms which grow in water. Especially active in summer conditions, where chlorine disinfectant level is too low to destroy them. Algae may be green, yellow, brown or black (Black Spot) in color.
- 6.6.2 **Chlorine Demand.** The amount of chlorine that should be added to the water to provide proper bacteria and algae control.
- 6.6.3 **Chlorine Residual.** The amount of chlorine left over, after the “demand” has been met.
- 6.6.4 **Combined Chlorine.** Weak chlorine which is combined with the contaminants in the water.
- 6.6.5 **Free Chlorine.** Active chlorine in the water with the potency to destroy contaminants.
- 6.6.6 **Shock Treatment.** The removal by means of oxidation of those materials that have chlorine demand.

7.0 ADDING SALT TO POOL OR SPA

7.1 Adding Salt

- 7.1.1 DO NOT add pool/spa chemicals directly to the skimmers (if applicable). This may damage the cell. Maintaining high salt levels above the recommended range can contribute to corrosion of pool/spa equipment. If the chlorinator has already been installed, it must be turned off before adding salt. The recommended salt concentration for the E-Series is **3500 ppm**.
- 7.1.2 It is best to empty the required salt around the perimeter of the pool and run the filtration simultaneously while the E-Series chlorinator is off to circulate the water and dissolve the salt. Do not throw salt bags into the pool or spa as chemicals and inks on the bag can interfere with the water balance.
- 7.1.3 Salt may take 24 – 48 hours to dissolve in the summer and longer in the winter. Finer granules of salt will dissolve faster than compressed pellets.

7.2 Type of Salt to Use

- 7.2.1 The purer the salt the better the life and performance of the electrolytic cell. Use a salt that is at least 99.8% pure NaCl. The preferred salt is an evaporated, granulated, food quality, non-iodized salt.
- 7.2.2 Avoid using salt with anti-caking agents (sodium ferrocyanide, also known as YPS or yellow prussiate of soda) that could cause some discoloration of fittings and surface finishes in pool.
- 7.2.3 Water conditioning salt pellets are compressed forms of evaporated salt and may be used but will take longer to dissolve.
- 7.2.4 Do not use calcium chloride as a source of salt (use sodium chloride only).
- 7.2.5 Do not use Rock salt. Insoluble impurities mixed with the rock salt can shorten the life of the unit.

7.3 Salt Level

- 7.3.1 The Compu Pool E-Series chlorinator can work with a broad salinity range, from a minimum of 3000 ppm (parts per million), up to 6000 ppm. However, the ideal level for operation is 3500 ppm. To achieve this level of salinity, add 3.5kg. of salt for every 1000 litres of water. If you are unsure of the number of litres in the pool, double-check with the equations below.

Pool Shape	Litres (Measurements in Metres)
Rectangular	Length x Width x Average Depth x 1000
Round	Diameter x Diameter x 3.14 x Average Depth x 1000
Oval	Length x Width x Average Depth x 0.668 x 1000

-
- 7.3.2 The ideal salt level is 3500 ppm. A low salt level will reduce efficiency of the chlorinator and result in low chlorine production. A high salt level can cause a salty taste to the pool. In addition, operating the unit outside the recommended salt range will rapidly reduce the longevity of the cell. The salt in the pool/spa is constantly recycled and the loss of salt throughout the swimming season should be small. This loss is due primarily to the addition of extra water to replace water lost from splashing, backwashing, and draining (because of rain). Salt is not lost due to evaporation.
- 7.3.3 If salt content is too high you will need to reduce the level of water in the pool/spa and refill the pool/spa with fresh water that has not been diluted with salt.

8.0 INSTALLATION

8.1 Positioning

- 8.1.1 **WARNING: The E-Series chlorinator must be installed in a dry and well ventilated room or area that is protected from the environment, rain and direct sunlight. The chlorinator must not be installed into a location that is used for chemical storage as this will void the warranty.**
- 8.1.2 Water leaks, no matter how small should be attended to immediately. If there is water in the vicinity of the chlorinator, condensation may form on the internal electrical components which can result in malfunction. The warranty will not cover malfunction due to condensation or weather.
- 8.1.3 Positioning should allow for easy access to the Electronics Module control panel, circuit breaker door, access panels, and the Cell Module.

8.2 Electronics Module

- 8.2.1 The Electronics Module should be installed at least 1.5 metres away from the Cell Module.
- 8.2.2 The Electronics Module must be lifted and moved by two people. Lifting by one person may cause serious injury. The Electronics Module may weigh up to 40kg, depending on the model.
- 8.2.3 The Electronics Module can be installed by either the use of the wall mounting bracket, or the four articulated feet on the base of the enclosure.
- 8.2.4 To install with the four articulated feet, place the enclosure on a sturdy shelf or table. The articulated feet can be adjusted to level the unit if desired. Do not place or install the Electronics Module on the floor / ground.
- 8.2.5 To install with the wall mounting bracket, carry out the following procedure.



01. Determine the desired position for the Electronics Module on the wall. Screw the wall mounting bracket shown to the wall with the nine screws provided. If wall plugs are required, use the bracket as a template to mark the locations for drilling the holes.



02. Ensure that the four M10 screws are assembled into the rear of the electronics enclosure.



03. Check that there is a small gap (approximately 0.1" / 2mm) between the screw head and the enclosure sheetmetal. This will allow for mounting onto the bracket keyhole details.



04. With two people, lift the Electronics Module up. Carefully align the four M10 screw heads with the corresponding keyhole apertures. Push the screw heads through the apertures and let them fall into the slot. The Electronics Module should now be securely mounted.

8.3 Cell Module

- 8.3.1 The Cell Module is installed with the use of the Cell Mounting Bracket in the vertical position with the Cell Head facing upwards. To install with the Cell Mounting Bracket, carry out the following procedure.

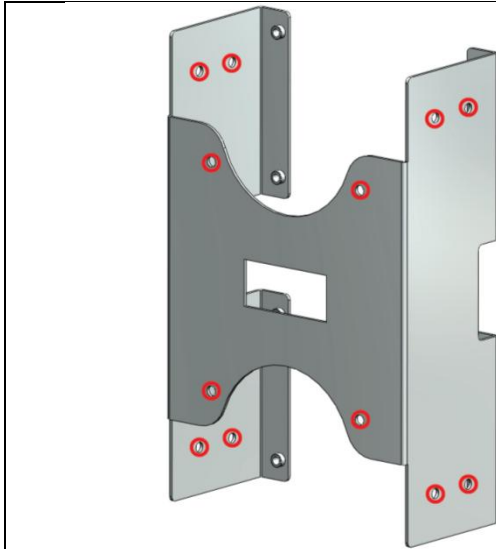

01. The Cell Mounting Bracket can be mounted to a wall or sturdy post with either of the three faces with the four holes (Ø0.40" / Ø10mm). Determine which mounting option would suit the desired plumbing configuration. Use strong screws or bolts to fasten the Bracket to the mounting surface.

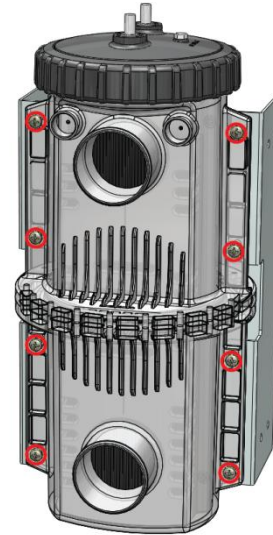

02. With two people lift and position the Cell Module onto the Mounting Bracket and assemble the eight M8 screws to firmly hold the Cell in place.

Note: To protect the Cell Module during shipping, it will be pre-assembled to the Mounting Bracket. The Cell Module will need to be removed from the Mounting Bracket to undertake this installation.

8.4 Plumbing

- 8.4.1 The chlorinator must be plumbed downstream from the filtration plant. Any heating equipment should be installed into an adjacent bypass line to the Cell Module. This will result in the Cell Module not being exposed to water from the heater, and the heater not being exposed to water from the Cell.
- 8.4.2 A branch line needs to be taken from the main filtration return line and diverted through the Chlorinator to create a bypass installation. This must be done in the manner shown in the plumbing diagram in the following section (Figure 1). Installing the Chlorinator in this manner avoids excessive pressure on the Chlorinator and filtration system. Additionally the Chlorinator can be isolated from the main flow return line to enable uninterrupted filtration.
- 8.4.3 The bypass installation must be made from 3" (80mm) or 2" (50mm) PVC pipe. The Inlet and Outlet spigots on the Cell Module take a 3" (80mm) fitting, if a 2" (50mm) installation is desired then a reducer will need to be used.
- 8.4.4 The flow sensor must be installed in the bypass line before the Chlorinator as shown in the plumbing diagram (Figure 1). Chlorine production will only occur when the flow sensor detects sufficient water flow, thus protecting the electrolytic cells. The flow sensor and the flow sensor 3" (80mm) plumbing fitting are shipped inside of the Electronics Module. To remove the sensor and plumbing fitting take off one of the Electronics Module access panels. Ensure that there is no power connected when this is done.
- 8.4.5 The M1 Valve (inlet) and M2 Valve (outlet) are used to allow the flow of water through the Chlorinator.
- 8.4.6 The M3 Valve can be used to direct a portion of the main line flow through the Chlorinator line. In most installation scenarios this valve can be left fully open.
- 8.4.7 Once the plumbing is completed the bypass line valves should be slowly opened to check for proper hydraulic sealing. Ensure that the Cell Collar is tightly assembled to the Cell Housing prior to this.
- 8.4.8 The E-Series Chlorinator has been designed to operate with a maximum working pressure of 40Psi (275kPa). Damage to the Cell Module may occur if the working pressure exceeds this limit.

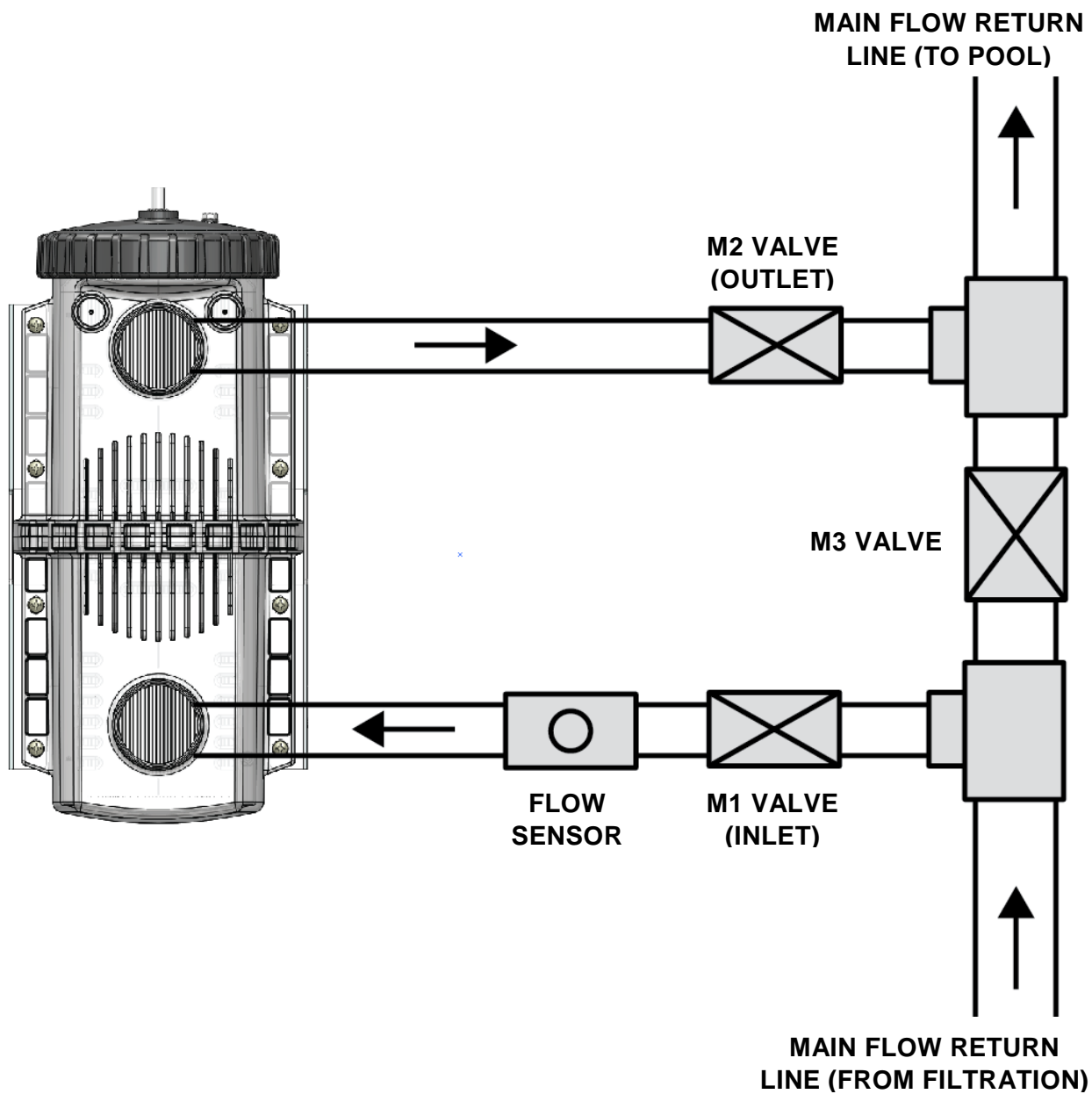

8.4.9 Figure 1: Plumbing Diagram

8.5 Wiring

- 8.5.1 **WARNING:** Before wiring ensure that the power is turned off at the source.
- 8.5.2 Power must also be shut off at the Chlorinator circuit breakers before performing any wiring. Be sure to follow local and NEC electrical codes.
- 8.5.3 The Electronics Module inputs and outputs are indicated with labels on the enclosure as shown below.

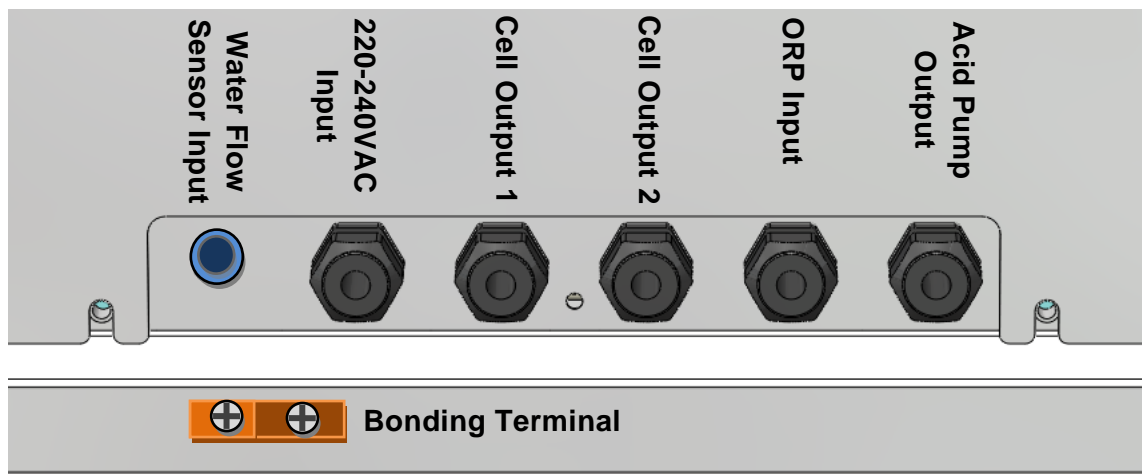

8.5.4 Figure 2: Electronics Module Inputs and Outputs

- 8.5.5 The single phase input (220-240VAC) is not provided with a pre-wired cable, this will need to be installed into the electronics module through the liquid tight cable gland provided. The E-Series unit will need to be connected to the power source with a cable that meets local and National Electrical Code(s). The 220-240VAC input must be connected by carrying out the following procedure by a qualified electrician.

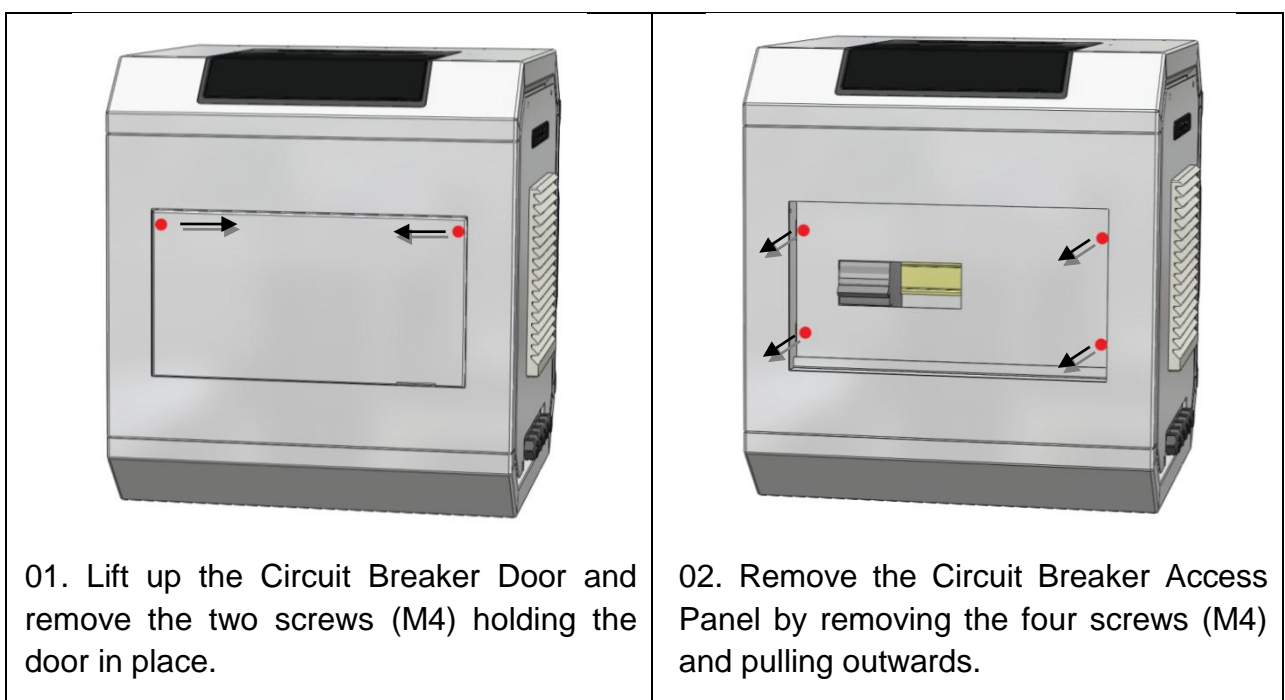



03. Remove the Electronics Module Access Panel (right side) by loosening the two bottom screws and removing the two top screws.

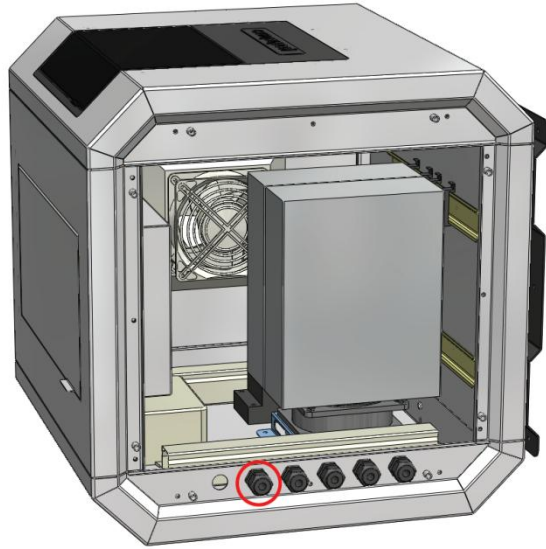

04. Feed the power cable into the Electronics Module through the appropriate cable gland (see 8.5.3).

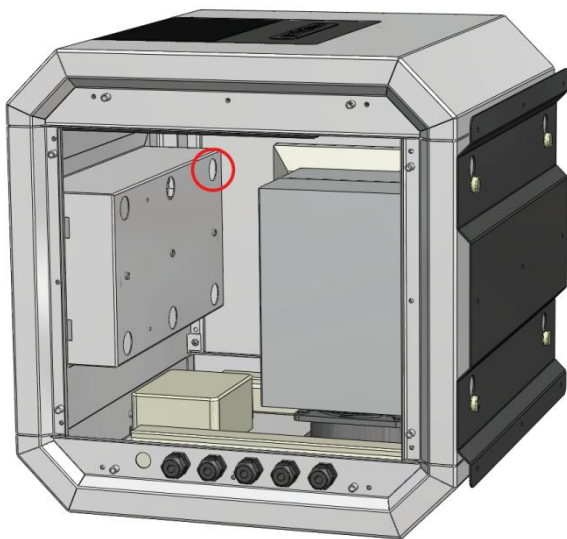

05. Feed the power cable through the Electronics Module and the top left cable aperture on the Circuit Breaker compartment.



06. With the cable entering the Circuit Breaker compartment: Connect the active wire to Supply Active (L1). Connect the neutral wire to Supply Neutral (N1). Connect the earth wire to Supply Earth In (E). Refer to Figure 3 - Terminal Wiring Diagram, for correct wiring positions.







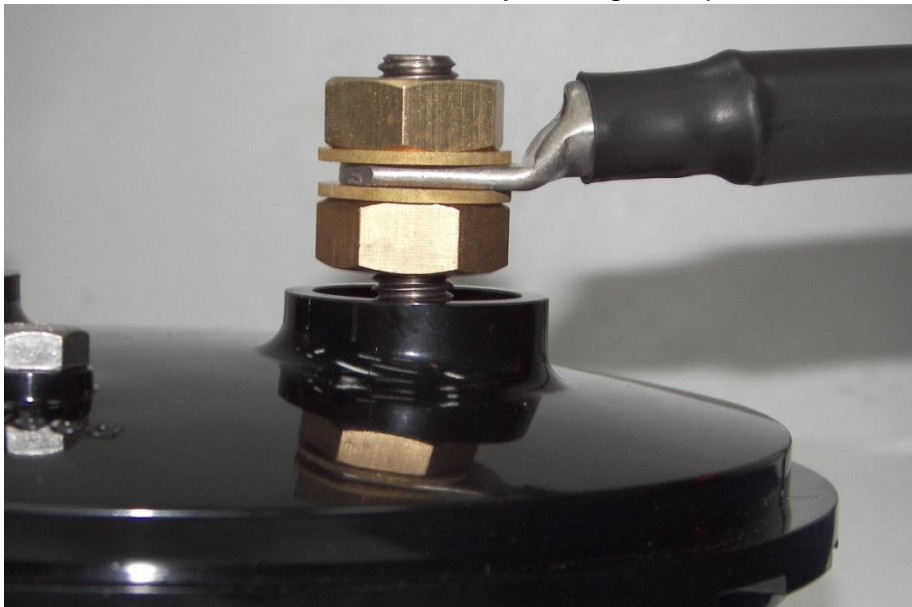



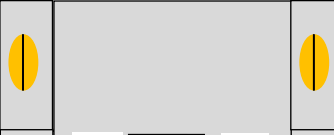
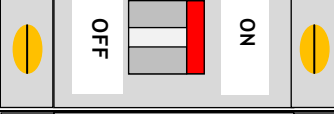
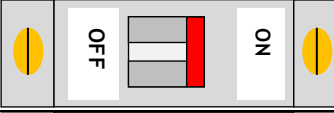
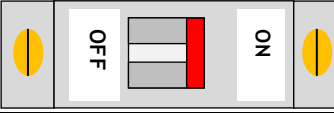
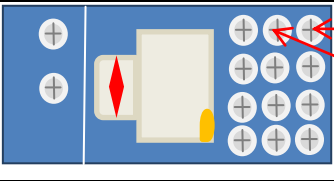
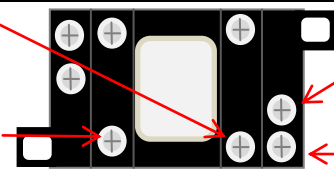

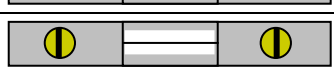
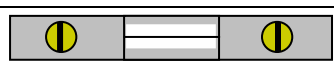
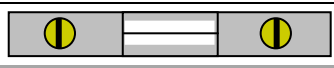
07. Replace the Circuit Breaker Access Panel and the Circuit Breaker Door. Replace the Electronics Module Access Panel (right side).

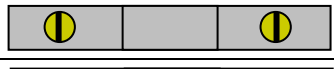
08. Check that earthing conforms to required standards and codes.

-
- 8.5.6 The ORP input is not provided with a pre-wired cable, this will need to be installed into the electronics module through the liquid tight cable gland provided if required. The wires need to be connected to the ORP 110V AC relay as shown in Figure 3. The wires can be connected to either terminal. Conversion kits for 24VAC and 240VAC ORP inputs are also available as a spare part.
- 8.5.7 Connect the two Cell Output cables to the cell head in the manner shown in the image below. Place the cable terminal between the brass washers and nuts. Using two wrenches tighten the nuts (24mm flats) together firmly with a torque of approximately 60 foot pounds (80 newton meters). Do not tighten the brass nuts down onto the cell head as this may damage the part.



- 8.5.8 Connect the Water Flow Sensor cable to the input socket.
- 8.5.9 A bonding terminal is located on the metal electrical enclosure of this device (see 8.5.3). To reduce the risk of electrical shock, this terminal must be connected to the grounding means provided in the electrical supply.
- 8.5.10 **WARNING:** Installation of electrical wiring should only be performed by a qualified electrician. Failure to do so could result in serious harm and electrocution.

220VAC	NA	Neutral to Switchmodes		Supply Neutral	N1	220VAC
	1A	Active to Switchmodes		Supply Active	L1	
	1B	Aux Circuit Breaker Active to fused inputs		Supply Active	L1A	
	NB	Aux Circuit Breaker Neutral to fused inputs		Supply Neutral	N1A	
110VAC	ORP Input			Override Output	OVR	
	ORP Input			Override Output	OVR	
220VAC	APB2	Active From Fuse Protected L1		Acid Pump Control	APR	12VAC
	APB1	Active to Acid Pump		Acid Pump Control	APR	
0V	E	Earth to Earth Stud Earth to Door Fan		Supply Earth in	E	0V
220VAC	APC	Fuse Protected L1 to Acid pump relay		L1 From AUX Circuit Breaker	1C	220VAC
	SFA	Fuse Protected L1 to Switchmode Fans		L1 From AUX Circuit Breaker	1C	
	DFA	Fuse Protected L1 to Door Fan		L1 From AUX Circuit Breaker	1C	
	TFA	Fuse Protected L1 to Transformer		L1 From AUX Circuit Breaker	1C	
	APN	Neutral to Acid Pump		Neutral From Circuit Breaker	NC	
	SFB	Neutral to Switchmode Fans		Neutral From Circuit Breaker	NC	
	DFB	Neutral to Door Fan		Neutral From Circuit Breaker	NC	
	TFB	Neutral to Transformer		Neutral From Circuit Breaker	NC	
12VAC	TO	Transformer Output		Transformer Input	TI	12VAC
	TO	Transformer Output		Transformer Input	TI	
24VDC	SWP	Switchmode Positive Out		Switchmode Positive Out	SWP	24VDC
	CP	Cell Positive Out		Switchmode Positive Out	SWP	
	SWN	Switchmode Negative Out		Switchmode Negative Out	SWN	
	CN	Cell Negative Out		Switchmode Negative Out	SWN	

8.5.11 Figure 3: Terminal Wiring Diagram

9.0 INSTALLATION CHECKLIST

- 9.1.1 Plumbing work completed as per the provided plumbing diagram.
- 9.1.2 All valves working and assembled correctly.
- 9.1.3 All valves and joints checked for correct hydrostatic sealing with no leaks.
- 9.1.4 Power and control input wired correctly as per the provided terminal diagram.
- 9.1.5 Earth wire correctly grounded to the earth terminal.
- 9.1.6 Cell lead connections are tight.
- 9.1.7 Cell Module locking collar is tight.
- 9.1.8 Circuit breakers are working correctly.
- 9.1.9 Sufficient salt has previously been added and fully dissolved into pool water.

10.0 USING THE CONTROL PANEL

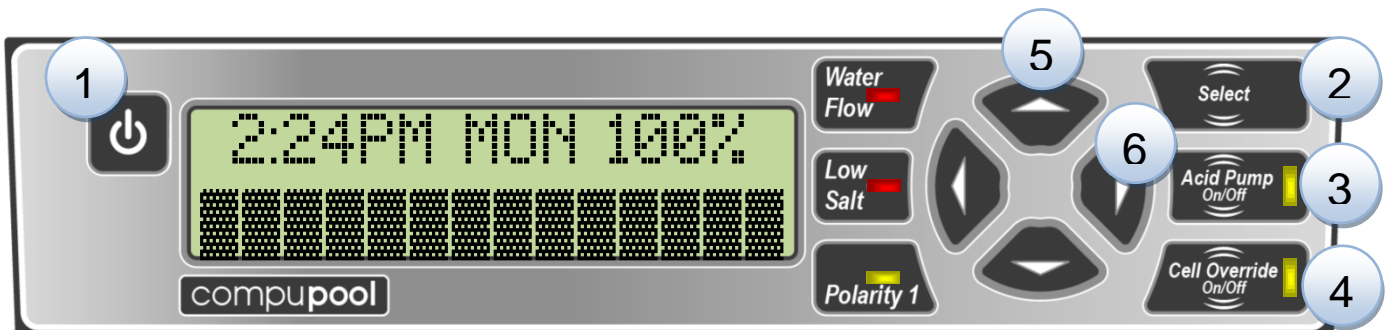

10.1 Control Panel Buttons

1. **On / Off.** For normal operation, the system should be left in the “On” position. In this position the Compu Pool E-Series will produce chlorine according to the desired output %. Simply press the button again to turn the unit off.
WARNING: Off does not electrically isolate the Power Module, the fans will operate when Off.
2. **Select Button.** Pressing this button will open the menu that provides the following options:

-
- a. Language (factory setting "English"): To change the language simply press the up or down arrow to scroll through the language options.
 - b. Which Timer (factory setting "Use External"): Use the down arrow to select "Use Internal". Press the up arrow to select "Use Trigger". The trigger option is selected when using a ORP input. When the ORP input is activated the "Cell Override" LED will turn on and chlorination will start.
 - c. Set Clock: When setting the clock time use the up and down arrow buttons to select the hour and minutes. Use the left and right buttons to move the cursor between hour and minutes. If the "Use Internal" timer option is selected the two On and Off times then need to be set. These are the running periods for chlorine production.
 - d. Low Salt Trim: This is used to adjust the "Low Salt" level.

3. Acid Pump. An Acid Wash System can be supplied as an additional accessory to the E-Series Chlorinator. Pressing the acid pump button will turn the acid pump on or off. Before using this feature ensure that the M1 and M2 valves are closed (refer to Figure 1 - Plumbing Diagram). The acid pump will not run if any water flow is detected.

Also ensure that the electrolytic cells are full of water and the acid tank has been filled to the correct levels with acid solution. If the pump is run dry damage will occur. For further instructions see the information provided with the Acid Wash system.

4. Cell Override. When this button is pressed on and the timer is set to "Use Internal" Chlorine production will commence. Press again to turn this function off.

5. Up and Down Arrows. Pressing the Up or Down arrow will enable navigation through the menu options.

6. Left and Right Arrows. Pressing the Left or Right arrow will enable parameter adjustments in the menu.

7. Output. Pressing the up or down buttons on the home screen will change the CHLORINE PRODUCTION output in 10% increments.

10.2 Control Panel LED Indicators

10.2.1 Polarity 1. For single polarity units the Polarity 1 LED will always remain on. For dual polarity units the LED will remain on for Polarity 1 and off for Polarity 2.

10.2.2 Water Flow. The water flow warning LED will be illuminated if the flow sensor detects no flow. Chlorine production will only occur when water flow is detected.

10.2.3 Low Salt. The Compu Pool E-Series will automatically let you know if the salinity concentration has fallen below acceptable levels. The warning LED will be illuminated when salt levels fall below 2500ppm. When this warning is illuminated add more salt to the pool to return the residual salt to the correct level of 3500ppm.

10.2.4 **Acid Pump.** The acid pump LED will be illuminated while the acid pump is turned on. Warning: Do not run the acid pump dry as damage will occur, do not run the acid wash cycle for more than 30 minutes.

10.2.5 **Cell override.** The cell override LED will be illuminated while this feature is turned on.

11.0 MAINTENANCE

11.1 Water Chemistry

11.1.1 It is recommended that a pool water is tested by a Pool Professional as per the following schedule and according to country / state regulatory requirements. These results should be recorded in a maintenance log.

Daily Checks		Monthly Checks	
Free Available Chlorine	1.0 – 3.0 ppm	Total Alkalinity	100 – 120 ppm
pH	7.2 – 7.8	Calcium Hardness	200 – 300 ppm
		Stabilizer (Cyanuric Acid)	30 – 60 ppm
		Total Dissolved Solids	< 1,200 ppm
		Salt Residual	Optimal 3500 ppm

11.2 Electrolytic Cell

11.2.1 The cell operates most efficiently when it is clean. As a natural result of the electrolytic process which creates chlorine, calcium build up is attracted to the titanium plates in the cell. The cell requires regular cleaning to ensure that build up does not cause individual plates to come in contact with each other. The clear housing of the cell allows easy visual inspections, however as a general rule the cell should be cleaned every 4 weeks for non reversing systems.

11.3 Cleaning the Cell Manually

11.3.1 Remove the Cell as explained in point 11.6.

11.3.2 Note: This procedure must be carried out with care in a well ventilated area. Read and observe the relevant Material Safety Data Sheet (MSDS) and always wear Hydrochloric Acid resistant protective clothing. Observe all relevant occupational health and safety procedures.

11.3.3 With the cell removed use a high pressure hose nozzle to spray off as much loose scale and debris as possible.

11.3.4 Do not use any sharp or metallic objects to remove scale. Scraping or scratching the cell plate's edge or surface will allow chemical attack of the plate, cause premature failure of the cell and will void the warranty.

-
- 11.3.5 If further cleaning is required the cell needs to be cleaned in a mixture of one (1) part Hydrochloric (Muriatic) Acid into five (5) parts water (always add acid to the water).
 - 11.3.6 **WARNING:** When using the acid ensure to use rubber gloves and appropriate eye protection.
 - 11.3.7 Mix the acid and water in a suitable container and place the cell into the container . Cell cleaning tubes are available from Compu Pool as an additional accessory. Ensure that the acid solution fill line is below the Cell Head area, submersion of this area will damage the cells electronics and void the warranty.
 - 11.3.8 Clean the cell until the foaming action stops (typically 5 to 10 minutes). Rinse the cell with fresh water and re-install into the plumbing line.
 - 11.3.9 Note: Excessive cleaning will reduce the lifespan of the cell.

11.4 Cleaning the Cell with the Acid Wash System

- 11.4.1 Follow the instructions provided with the Acid Wash System to carry out this procedure.

11.5 Replacing the Cell

- 11.5.1 When the titanium blades inside the Electrolytic Cell have reached the end of their lifespan, replacements are available so that the whole system does not have to be removed. Replacements are easily switched out. To ensure quality and value, only genuine Compu Pool replacement parts may be used.

11.6 Removing the Cell for Replacement or Cleaning

- 11.6.1 Turn off the power to the unit. Disconnect the nuts clamping the cell leads to the cell heads with the appropriate sized wrench / socket (24mm).
- 11.6.2 Turn valves M1 and M2 to the closed position.
- 11.6.3 Unscrew the air bleed bolt at the top of the cell head. The air bleed bolt should only be removed and re-assembled by hand. Over tightening the bolt will crack the cell head.
- 11.6.4 Unscrew the cell head collar.
- 11.6.5 With a large flat bladed screwdriver carefully leverage the cell out of the housing enough so that it can be lifted out by hand. Carefully remove the cell.
- 11.6.6 Insert the new cell in the reverse manner. Check that the Cell Head o-rings are in good condition and apply a suitable o-ring lubricant if they are dry. Ensure that the cell head collar is screwed down tightly and that the nuts clamping the cell leads to the cell head are tight (see 8.5.7).

12.0 WARRANTY

12.1 Warranty Terms

- 12.1.1 Compu Pool E-Series chlorine generators carry the following **two year warranty** should fault occur due to faulty manufacturing or materials.
- 12.1.2 Compu Pool warrants the original purchaser that the equipment shall be free of manufacturer defects at the time of sale and upon examination, shall provide replacement parts or repair in accordance with the following schedule:
- 12.1.3 **First Year.** Parts supplied from our facility or returned for repair to our facility at no cost. Compu Pool reserves the right to determine whether or not a part will be replaced with a new or refurbished part or repaired.
- 12.1.4 **Second Year.** Parts supplied from our facility or returned for repair to our facility at no cost. Compu Pool reserves the right to determine whether or not a part will be replaced with a new or refurbished part or repaired.

12.2 Void Warranty

- 12.2.1 The warranty may be void if the following occurs:
- 12.2.2 Damage to the unit beyond Compu Pool's control.
- 12.2.3 Damage due to improper pool chemistry.
- 12.2.4 Damage due to improper installation.
- 12.2.5 Damage due to failure to properly maintain unit.
- 12.2.6 Damage due to improper service.
- 12.2.7 Damage caused by insects or natural elements.

12.3 Warranty Coverage

- 12.3.1 This warranty is applicable to workmanship and materials only and Compu Pool, its agents, employees, and affiliates expressly disclaim responsibility for loss, damage, or injuries to persons or property arising from warranty failure, or installation of equipment. Warranty claims must be initiated in a timely manner by calling:

+61 (0)7 5596 3773

12.4 Customer Warranty Information

12.4.1 Please complete the information below at time of installation and retain in the event you need to file a warranty claim.

Model Number	
Voltage	
Electronics Module Serial Number	
Cell Module Serial Number(s)	
Purchase Date	
Purchased From	
Installation Date	
Installer	
Installation Address	