

PORTABLE ASPEN

Part Number 42643



SPECTRUM[®]
Aquatics

A PLAYCORE Company

7100 Spectrum Lane ~ Missoula MT 59808
800.791.8056 ~ www.spectrumproducts.com

You have purchased a Spectrum Products Portable Aspen Lift. Providing the unit is installed correctly and properly maintained, it will furnish you with many years of trouble free use. It is important to read this entire manual prior to beginning assembly or operation of the unit.

Shipping Information:

Each Portable Aspen will arrive partially assembled in two separate units, a box containing the lifting components and a pallet containing the mobile base. Before accepting the Portable Aspen from the carrier, inspect for visible damage and match the contents with those listed below. Although we take every effort to ensure a timely and complete delivery, Spectrum is not responsible for lost or damaged freight.

The following is a list of the components included with your shipment from Spectrum. Use Components and Hardware Figure, pages 2-3, as a reference to identify each item listed (* indicates not shown on pages 2-3)

Pallet		Box	
1	Mobile Base Assembly	1	Mast Assembly
15	Weight Pellet Bags*	1	Adjustable Footrest Assembly
1	Handle	1	Seat Pole Assembly
2	Stabilizer Arms	2	Wireless Transmitters*
		1	Charger *
		2	Armrests (1 ea. Right and Left)
		1	Seat Belt Assembly
		1	General Hardware Pack*
		2	Seat Halves
		1	Battery
		1	Portable Aspen Cover*
		1	Headrest

Components and Hardware

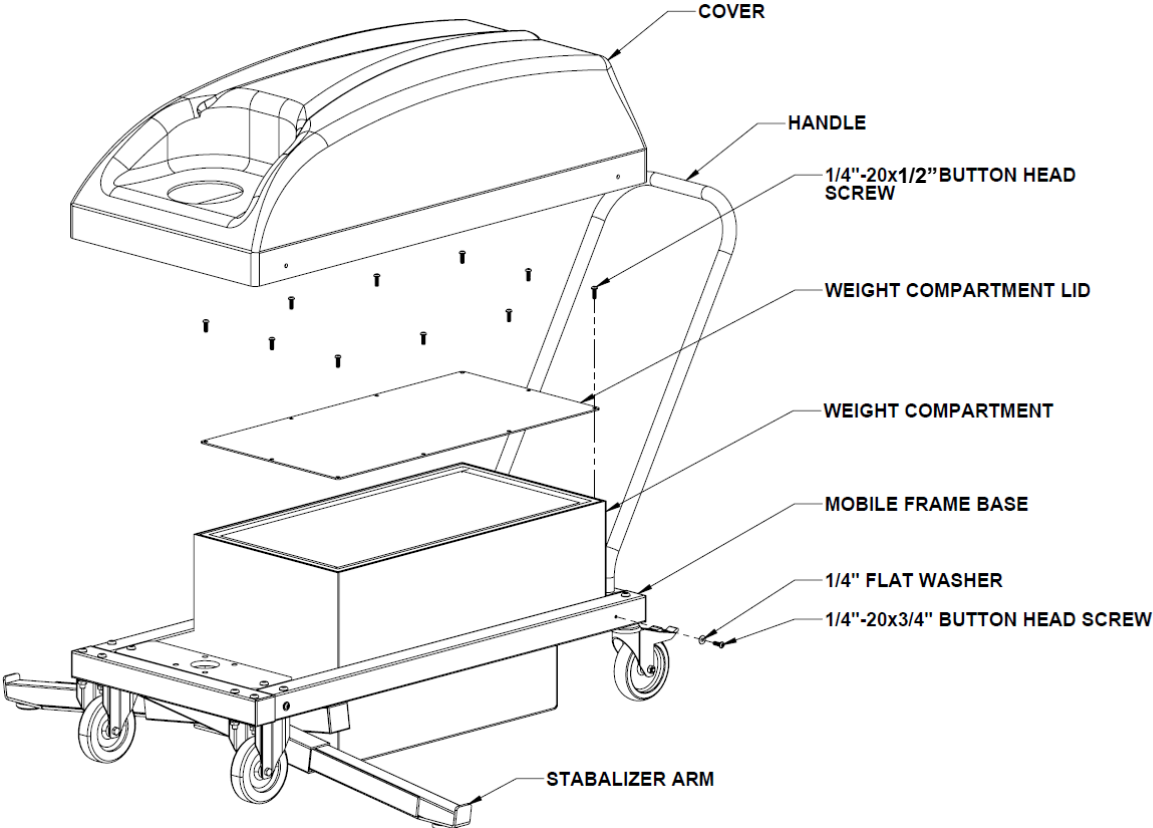

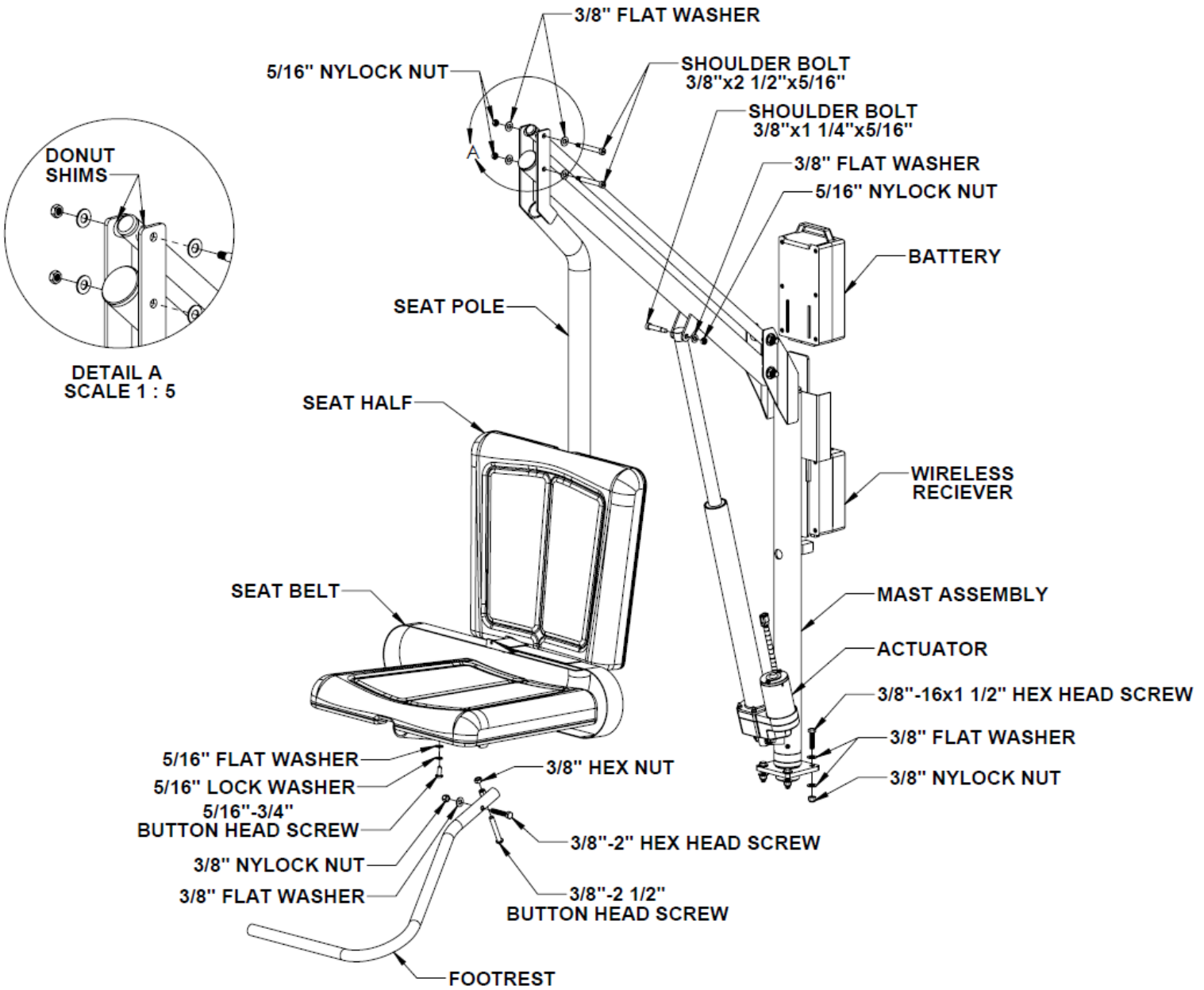

PRODUCT OVERVIEW

Spectrum Products introduces the new Portable Aspen aquatic lift.

The Portable Aspen allows for the flexibility of use and ease of installation around the pool deck, into storage or from pool to pool. The Portable Aspen is safe and easy to operate. It has two high performance locking casters and two pull-out locking stabilizers for added safety and stability.

ASSEMBLY

The following tools will be required to complete assembly and installation of the Mobile Base and Aspen Lift:

- 9/16" ratchet and open-end wrench
- 1/2" ratchet or open-end wrench
- 3/16" socket wrench (Allen wrench)
- 5/32" socket wrench (Allen wrench)

Mobile Base Assembly

Read all instructions before attempting to assemble or install the Portable Aspen lift.

Before you begin assembly of the Portable Aspen lift, determine where it will be located. It is recommended that the Portable Aspen Mobile Base has the weight added at the deck level intended for use, as it is difficult to relocate due to the weight of the base unit.

1. Remove all parts from crate.
2. Install stabilizer arms if they are not already in place (ensure that rubbers pads face the deck when inserting stabilizer arms)
3. Remove cover and weight compartment lid
4. Carefully empty bags of weight pellets into the weight bin on the Mobile Base.

!Caution! Weight bags are heavy handle carefully

5. Using (10) 1/4-20 x 3/4 button head screws reinstall the weight compartment lid onto the weight compartment. Ensure that the flange is free from weight pellets that would prevent the gasket from sealing the weight compartment.
6. Attach the cover with the included hardware and insert the handle into the holes on the rear of the Mobile Base.

Aspen Lift Assembly

NOTE: All steps reference the exploded view on page 3.

- a. Stand the mast assembly on the mobile base stand as shown below and secure with (4) 3/8" x 1 1/2" hex head bolts, 8 3/8" Flat Washers, and (4) 3/8" Nylock nuts.

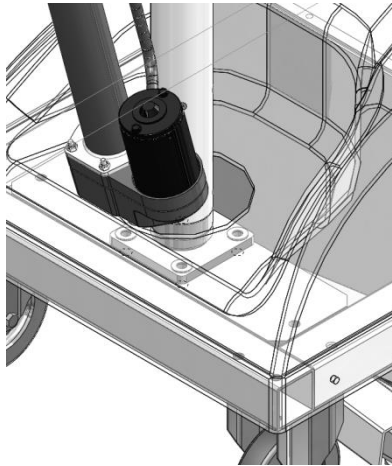

- b. Carefully remove shrink wrap holding the actuator to the mast assembly
- c. Attach the actuator end fitting as shown on page 3 using:
 - (1) - 3/8" Shoulder Bolt 1 1/4" x 5/16" - 18
 - (1) - 3/8" Flat washers
 - (1) - 5/16" - 18 Nylock nut
- d. Slide the battery down until it mates with the Wireless Receiver, and locks into place. Connect the battery cable to the receiver. When properly installed the battery will sit flush against the top of the Wireless Receiver. The Control Box battery indicator light should indicate a fully charged Battery (Green Light). If the battery indicator light does not illuminate, ensure that the battery is turned on by pressing the push button on the front of the battery case to the on (in) position. If the battery indicator light shows amber or red, charge battery before moving to the next step.
- e. Test lift operation by pushing the up and down toggle switch on the Wireless Receiver to ensure the lift is operational (See page 8 for instructions on using Wireless Transmitter). Then run the actuator into the fully extended position by pressing the up button until the actuator stops moving. Leave the lift in this position for the next steps.
- f. Join the seat arm to the mast assembly using:
 - (2) - 3/8" Shoulder 2 1/2" x 5/16" Thread

(4) - 3/8" Flat washers

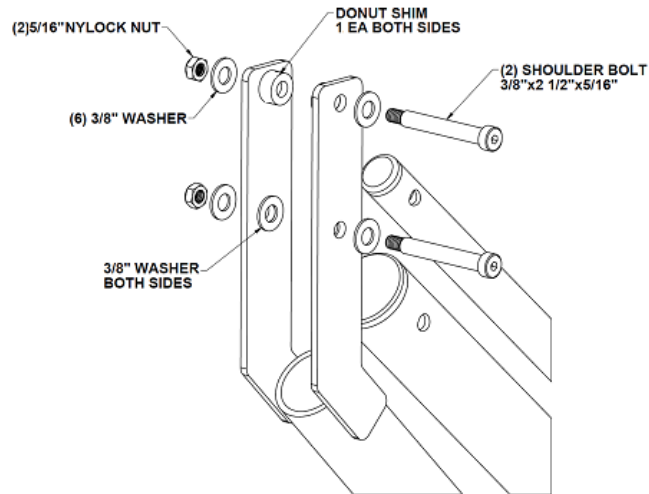

(2) - 5/16" - 16 Nylock nut
(2) - Donut Shims

g. Attach the seat half and the seat belt to the mounting plate of the seat arm using:

(2) - 5/16"-18 x 1"
(2) - 5/16"-18 x 3/4"
(4) - 5/16" Flat Washers
(4) - 5/16" Lock Washers

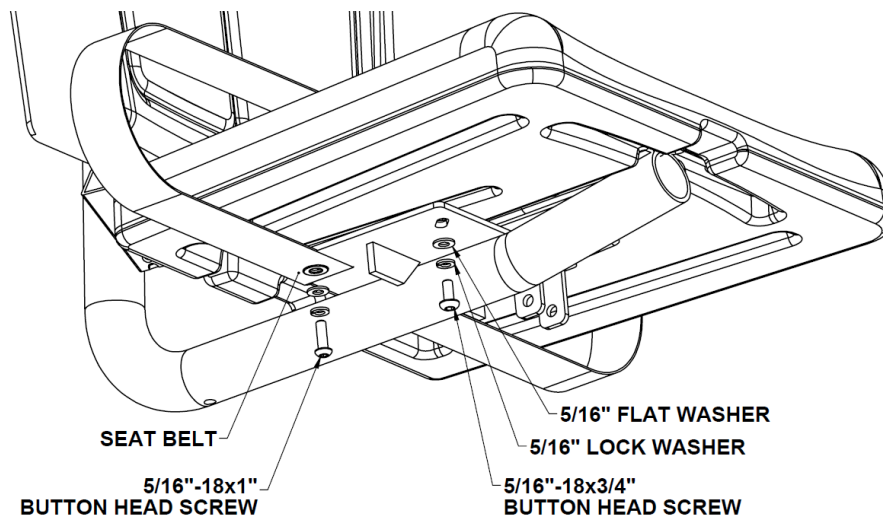

When attaching the seat belt use 5/16"-18 x 1" as shown below.

h. *Note:* Remove hardware on Headrest Assembly. Fasten to seat pole as shown. Do not tighten hardware. Adjust Headrest to desired position. Tighten hardware.

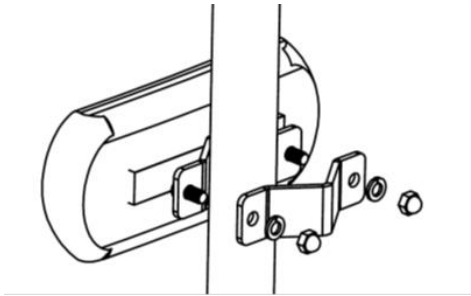

- i. Slide both armrests into their respective receivers behind the seat back; if the armrests are not running parallel with the seat (or look angled down), switch them.
- j. Install the adjustable footrest using the following hardware:
 - (1) - 3/8"-2" Hex Head Screw
 - (1) - 3/8" Flat Washers
 - (1) - 3/8" Nylock Nut
 - (1) - 3/8"-2" Button Head (Adjustment Bolt)

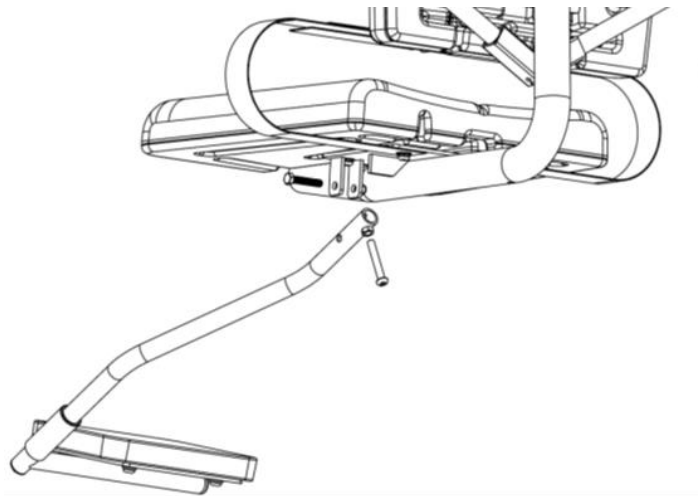

Tighten the bolt until the flat washers are snug, and then back off until the Footrest pivots freely. Adjust footrest to desired height using installed 3/8" - Button Head Bolt.

- k. The below image shows the proper way to assemble the seat belt.

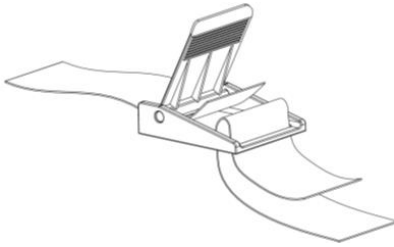

- l. Attach the other seat half to the back rest mounting plate using:

(4) - 5/16" - 18 x 3/4"

(4) - 5/16" Flat Washers

(4) - 5/16" Lock Washers

- m. Test the lift for proper operation.

- n. Install the Charger as shown on page 12 and charge the Battery for at least 8 Hours prior to use. The battery will reach full capacity after the first three charge/discharge cycles.

Operator's Guide

PRODUCT OPERATION

Use extreme caution when positioning the Portable Aspen. The Portable Aspen is heavy and once the unit is moving, it becomes hard to stop quickly.

Use caution when operating on sloped decks. **Do not use on deck area that has a slope greater than 1:48.**

Position the Portable Aspen at least 6" from the edge of the pool. Before each use of the Portable Aspen inspect the unit to ensure that all rear casters are locked and both stabilizer bars are tight to the deck in the fully extended position.

WARNING! Read all operating instructions before operating the unit. Make sure that all individuals using the unit have read the instructions and have been made aware of all safety precautions.

WARNING! DO NOT exceed the maximum lifting capacity of 300 lbs. This may result in damage to the lift or personal injury.

IMPORTANT OPERATION RULES

Position the Portable Aspen at least 6" from the edge of the pool.

Rear wheels **MUST** be locked **BEFORE USE!!**

Stabilizers **MUST** be touching on both sides and tight to the deck!!

Caution! Max weight of 300 #

Use extreme caution when transferring to or from the lift; it is the responsibility of the user to allow for safe operation of this lift.

To enter the Pool or Spa:

- A. Unlock remote by holding the Lock button on the transmitter for 3 seconds (lift will be operational for 2 minutes)
- B. Position the chair of the lift in the deck loading range (as shown in the diagram at right) using the directional buttons on the transmitter
- C. Carefully transfer into the lift seat from mobility device
- D. Fasten seatbelt
- E. Rotate the lift over the water (as shown, right: Enter/Exit water position) where it will not come into contact with the pool edge or any obstruction using the left or right buttons on the transmitter
- F. Lower the lift into the water until buoyant, by pushing the down button
- G. Unfasten seatbelt and carefully move away from the lift

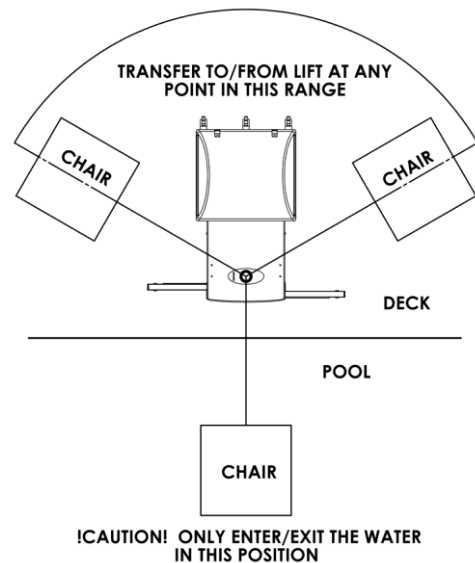

Using the directional buttons on remote return lift chair to a position in the deck loading range. To Exit the Pool or Spa:

- A. Unlock remote by holding the Lock button on the transmitter for 3 seconds
- B. Recall lift chair into water (as shown, right: Enter/Exit water position) to the previous depth upon transferring from the lift seat using directional arrows
- C. Carefully transfer into the lift seat
- D. Fasten seatbelt
- E. Lift the seat straight up using the up directional arrow on the transmitter until top of lifting stroke is reached
- F. Rotate the chair into the Transfer Range (As shown, right)
- G. Unfasten Seatbelt
- H. Carefully Transfer from lift seat into mobility device

WARNING! Read all operating instructions before operating the unit. Make sure that all individuals using the unit have read the instructions and have been made aware of all safety precautions.

Lift Operation

WARNING! Read all operating instructions before operating the lift. Make sure that all individuals using the lift have read the instructions and have been made aware of all safety precautions.

WARNING! Operate the lift exactly as described in the instructions above. Failure to do so may result in damage to the lift or personal injury.

WARNING! Do not exceed the maximum lifting capacity of 300 lbs. This may result in damage to the lift or personal injury.

WARNING! Do not rotate the lift directly into the deck or pool/spa wall. This may result in damage to the lift or personal injury.

WARNING! Unless operating in an emergency, Lift should not be forced to rotate. This could cause damage to the rotational components of the lift.

Basic Principals of Lift operation

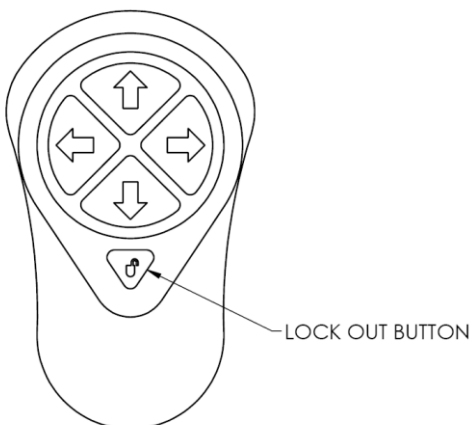

Activation of the Transmitter (Bottom Button, with a lock on it)

As a safety feature of this transmitter, there is a lockout button that is just below the four directional arrows. To activate the transmitter (wake from sleep mode), the lockout button needs to be pushed and held for a full 2 seconds. If

the transmitter is not used within two minutes after the transmitter has been activated, it will go back into sleep mode.

Lifting (UP)(▲):

Pressing the (▲) button causes the seat to rise. The seat will continue to rise as long as the button is pressed, or until the lift reaches its highest extent. Releasing the button at any time during travel will also cause the lift to stop.

Lowering (DOWN)(▼):

Pressing the (▼) button causes the seat to lower. The seat will continue to lower as long as the button is pressed, or until the lift reaches its lowest extent. Releasing the button at any time during travel will also cause the lift to stop.

Rotation (CLOCKWISE)(▶):

Pressing the (▶) button causes the lift to rotate clockwise. The lift will continue to rotate in this direction as long as the button is pressed. Releasing the button at any time during rotation will stop the lift from rotating.

Rotation (COUNTERCLOCKWISE)(◀):

Pressing the (◀) button causes the lift to rotate counterclockwise. The lift will continue to rotate in this direction as long as the button is pressed. Releasing the button at any time during rotation will stop the lift from rotating.

***Note: If the lift is overloaded at the seat, a clutch in the actuator will ratchet, this will be evident by a very noticeable clanking noise and the lift will shake but not move. After weight is taken off of the seat, the lift will resume normal operation. If this happens check the lift and pivots for structural damage before resuming a safe lifting procedure at or under the 300# working load limit.**

PROGRAMMING A NEW TRANSMITTER TO THE RECIEVER

***Note – The Transmitter will be programmed to the lift when you receive it; the only time you will have to follow this procedure is if you replace a Transmitter or buy an extra Transmitter.**

To Program a new transmitter to the lift, first disconnect the battery from the receiver. Hold the lockout button on the transmitter for two full seconds. Then press and hold the up button on the Transmitter to be programmed, while reconnecting the battery to the receiver. Continue holding the up button on the Transmitter until the lift clicks once or moves up (the lift is most likely at the top of its range, so you may try either rotation button and watch for lift movement). If the lift does not work with the new transmitter, try the procedure again; making sure that the transmitter is unlocked. If you are not able to program the new Transmitter to your lift, please call Spectrum Customer Service at 406-532-6321.

BATTERY CHARGING & INSTALLATION

The battery comes fully charged, but will need charging after the first several hours of use. Charging time is approximately twelve hours for the first few charges, four hours after the first two full battery cycles at which point the battery will reach maximum capacity. The lift comes with a battery charger for use in dry locations. Charge the battery as follows:

- Plug the battery charger into a standard* outlet. The green LED on the charger will light up, indicating that the charger is on.
- Plug the charging cable into the charging port on the back of the battery. If the battery is up to the charged voltage, the LED on the charger will stay green. If the charger determines that the battery needs to be charged, the LED on the charger will change to red.
- The red LED will turn green when the battery is fully charged. This charger has internal monitoring circuitry that will not overcharge the battery, if the battery is left on the charger for extended periods of time the charger will go into short charging cycles at intervals to keep the charge level at optimal.

***Charger accepts 110 VAC**

When the battery is fully charged, remove it from the battery charger and install the battery on the lift. The Battery Capacity Indicator on the receiver will show a green LED, indicating that the battery is fully charged and installed properly. When the LED changes to amber the lift is still OK to use. However when the LED changes to red, or an audible tone is heard during a lift cycle, the battery pack needs to be recharged.

To keep the battery from discharging to the point of causing damage, it is important to charge the battery at least once every 3 months, even if the battery has not been installed on the lift.

When the lift is not in use, and the battery is installed on the lift, the battery will hold a charge much longer if the push button switch is placed in the off (out) position. This electrically disconnects the battery from the unit, and will allow the battery to go up to 3 months without a charge cycle. If the switch is left on continuously, the battery may need to be charged weekly.

It is important to note that with this switch in the off (out) position, the battery capacity indicator light on the receiver will be off, and the lift will not work.

After initial break in, the battery should last approximately 90 cycles at the full 350# load rating of the lift before it needs recharging. The battery will need to be replaced after 500 to 800 charge cycles or 3-4 years if properly maintained (approximately 20,000 lifting cycles).

To activate the Emergency Up/Down rocker switch (located on the left side of the receiver), rock the switch and the lift will move in the direction indicated. These buttons can be used if the transmitter battery dies, or in the event of an emergency.

CHANGING A TRANSMITTER BATTERY

To change the transmitter battery, turn the transmitter over and unscrew four small Phillips head screws. Carefully open the transmitter case and remove the battery. This battery is stocked at most stores where coin batteries are sold, it is a 3V lithium Type 2032. Under normal operating conditions this battery should last at least two years.

Care and Maintenance

The following should be performed periodically to ensure safe and dependable use.

1. Remove any discoloration with a 3M scratch pad (stainless steel components only). Wipe clean with a sponge dampened with Spectra Clean. Repeat these steps several times to passivate the stainless steel. Spectra Clean kits are available from Spectrum (Part Number 202050-00). Do not spray with high-pressure water, only clean with non-chlorinated water.
2. Check all electrical connections – Check any external electrical cables for wear and/or breakage in the outer insulation.
3. Check all mechanical connections – inspect the Nylock Nuts on all moving parts and make sure they are snug. Lubricate all pivot points with light oil (3-1).
4. To maintain the battery properly, the battery must be fully charged at least every 3 months. If the battery goes for longer than 3 months without a charge, the battery will have reduced capacity.
5. Apply Dielectric grease to the battery connections and receiver connections where the battery and receiver meet. Any dielectric grease will work however Grote silicone dielectric grease is applied at the factory.

Troubleshooting

Problem:	Cause:	Solution:
1. Lift will not operate at all:	<p>Low Battery (Lift) – Red or amber LED on the receiver</p> <p>Damaged Battery (Lift) – Red LED on the receiver</p> <p>Dead Battery (Transmitter)</p> <p>Remote Locked</p> <p>Battery Fuse blown</p> <p>Battery Push button Switch in the off (out) position</p>	<p>Recharge Battery</p> <p>Replace Battery*</p> <p>Replace Battery</p> <p>3V Lithium 2032</p> <p>Push unlock button for 2 seconds</p> <p>Replace Battery Fuse</p> <p>Depress push button switch into the on (in) position</p>
2. The seat will not raise or lower.	<p>Low battery (Amber LED on Receiver)</p> <p>Battery not installed properly</p> <p>Receiver malfunction</p>	<p>Recharge battery</p> <p>Reinstall battery</p> <p>Replace Receiver*</p>
3. The seat's motion isn't smooth or sticks at a certain point during travel.	<p>Excessive wear to bearings</p> <p>Excessive wear to Actuator</p>	<p>Replace bearings*</p> <p>Replace Actuator*</p>
4. The seat travels much slower than normal.	<p>Low battery</p> <p>Defective or worn-out battery</p>	<p>Recharge battery</p> <p>Replace battery*</p>
5. The lift makes much more noise or unusual noises during operation.	<p>Excessive wear to bearings</p> <p>Pivot points galling</p>	<p>Replace bearings*</p> <p>Oil pivots with light oil (3-1)</p>
6. Battery will not charge:	<p>Charger Fuse Blown</p> <p>Bad Battery (red LED on charger – not turning orange or green in 4 hours or less)</p>	<p>Replace Charger Fuse</p> <p>Replace Battery*</p>

*Please contact your local distributor or Spectrum Customer Service to order parts 406.532.6321