



-
- SAVE INSTALLATION TIME AND AVOID CALL-BACKS •
 - READ THIS MANUAL BEFORE MOUNTING COLLECTORS •

SWIMMING POOL SOLAR HEATING SYSTEMS INSTALLATION MANUAL FOR AQUATHERM INDUSTRIES SOLAR COLLECTORS

FOR MODEL NUMBERS:

10001-5	10204-12	16104-12	16204-12	16404-12
10001-2	10204-10	16104-10	16204-10	16404-10
10001-1	10204-08	16104-08	16204-08	16404-08

MANUAL CONTENTS

This manual provides a detailed step-by-step procedure for the installation of an Aquatherm Industries solar pool heating system. If the directions are followed correctly and only recommended Aquatherm Industries hardware and components are used, the installed system should provide years of trouble free service, savings, and enjoyment.

CAUTION: SOLAR COLLECTORS ARE OFTEN INSTALLED ON THE ROOFS OF BUILDINGS. UNLESS YOU ARE VERY FAMILIAR WITH WORKING ON ROOFS AND HAVE THE PROPER LADDERS AND SAFETY EQUIPMENT FOR SUCH WORK, YOU SHOULD HIRE SOMEONE WITH THE NECESSARY EXPERIENCE TO DO THE INSTALLATION. FAILURE TO OBSERVE SAFE PRACTICES ON A ROOF OR OTHER ELEVATED STRUCTURE MAY RESULT IN FALLING, LEADING TO SERIOUS INJURY TO YOU.

MOUNTING COMPONENTS DIAGRAM

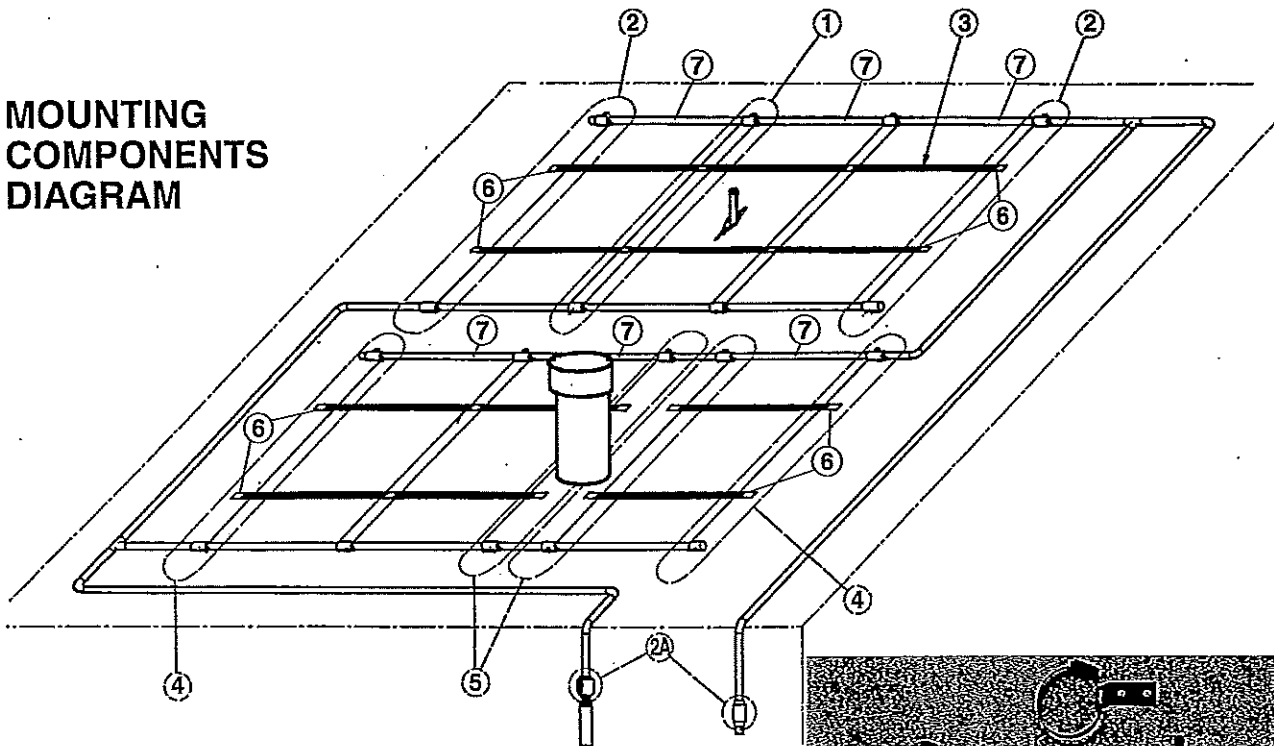

MOUNTING COMPONENTS

This section provides descriptions and part numbers of the Aquatherm Industries Installation Kits required for each solar pool heating system. The mounting location of each kit component is shown by the corresponding circled number in the 'Mounting Components' diagram, shown above.

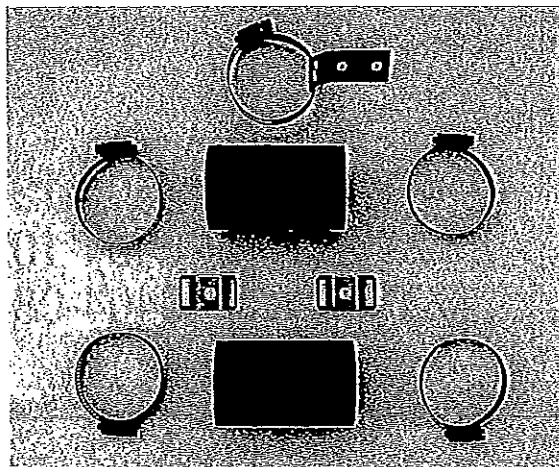

① The Collector Installation Kit (Part #12034-1 for 1 1/2" kit; #12034-2 for 2" kit) contains the parts needed to fasten a single solar collector to a supporting surface and to make water connections from one collector to another. Hold-down strap is not included and must be ordered separately. Use one (1) kit per collector.

Part No	Qty 1 1/2"	Qty 2"	Description
10008-1	1	—	Outlet header hold-down bracket assembly
10008-2	—	1	Outlet header hold-down bracket assembly
50006	2	2	Hold-down strap bracket
60648-1	2	—	Collector connector hose (3 3/4" long)
60648-2	—	2	Collector connector hose (3 3/4" long)
60546-1	4	—	Hose clamp, stainless steel
60546-2	—	4	Hose clamp, stainless steel

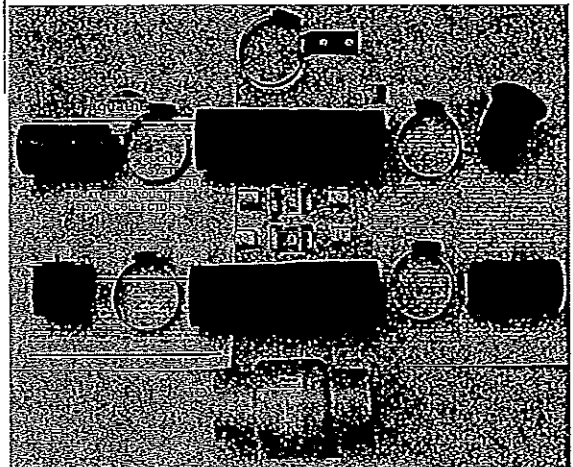

② The System Kit (Part #12135-1 for 1 1/2" kit; #12135-2 for 2" kit) contains additional hold-down hardware, connection parts and adapters needed to complete water connections from the collectors to the system feed and return line. The pipe adapters that connect the system piping to the collectors are high temperature CPVC. The system check valve is 1 1/2" - 2" PVC. Installation and homeowner manuals are also included. Use one (1) kit per system.

Part No	Qty 1 1/2"	Qty 2"	Description
10003-1	1	—	Vacuum Relief Valve
10003-2	—	1	Vacuum Relief Valve
10008-1	1	—	Outlet header hold-down bracket assembly
10008-2	—	1	Outlet header hold-down bracket assembly
10011	4	4	Hold-down strap clamp assembly
30061-1	1	—	End cap
30061-2	—	1	End cap
30089-1	2	—	Pipe adapter
30089-2	—	2	Pipe adapter
50006	2	2	Hold-down strap bracket
60649-1	2	—	System connector hose (7" long)
60649-2	—	2	System connector hose (7" long)
60546-1	4	—	Hose clamp, stainless steel
60546-2	—	4	Hose clamp, stainless steel
60019-2	1	1	Check Valve (1 1/2" & 2")
19001	1	1	Installation Manual
-----	1	1	Owner's Manual

②A The Optional Supplemental System Isolation Kit (Part #12033-5) includes a 1 1/2" - 2" PVC union ball valve and a 1 1/2" - 2" PVC check valve to permit manual isolation of the solar system from the pool or spa filtration system. Use one (1) kit per system.

③ Hold-Down Strap is required to secure collectors to the mounting surface. Use strap 10035-1 (54') for rows of up to 6 collectors or strap 10035-2 (107') for rows of up to 12 collectors. Available in bulk, 1400 ft. roll. Part #10040.

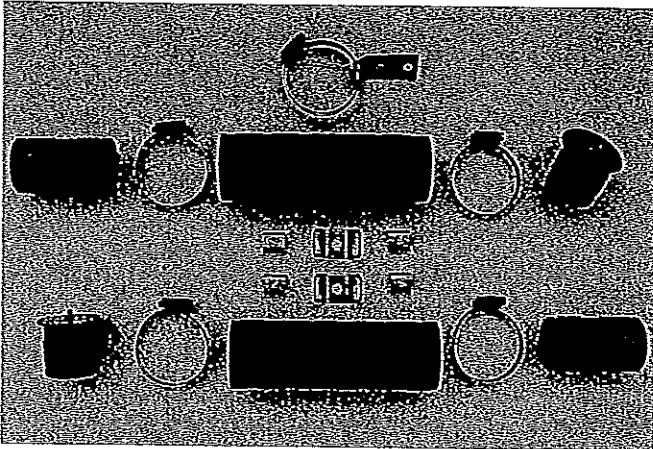

④ The Add-A-Row Kit (Part #12043-1 for 1 1/2" kit; #12043-2 for 2" kit) is used when more than one row of collectors is to be installed. Use one (1) kit for each collector row after the first.

Part No	Qty 1 1/2"	Qty 2"	Description
10003-1	1	—	Vacuum Relief Valve
10003-2	—	1	Vacuum Relief Valve
10008-1	1	—	Outlet header hold-down bracket assembly
10008-2	—	1	Outlet header hold-down bracket assembly
10011	4	4	Hold-down strap clamp assembly
30061-1	1	—	End cap
30061-2	—	1	End cap
30089-1	2	—	Pipe adapter
30089-2	—	2	Pipe adapter
50006	2	2	Hold-down strap bracket
60649-1	2	—	System connector hose (7" long)
60649-2	—	2	System connector hose (7" long)
60546-1	4	—	Hose clamp, stainless steel
60546-2	—	4	Hose clamp, stainless steel

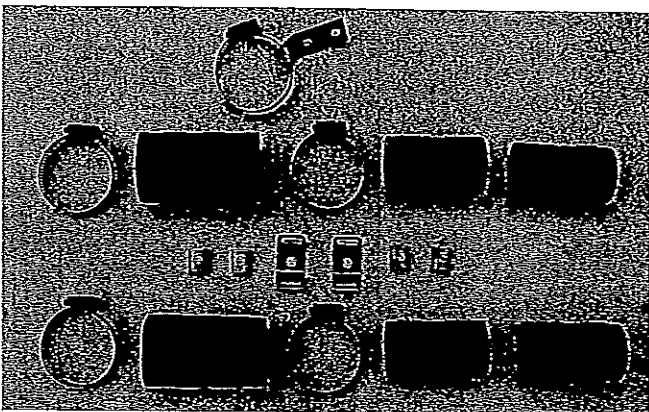

⑤ The Row Spacer Kit (Part #12017-1 for 1 1/2" kit; #12017-2 for 2" kit) is used when a row of collectors must be interrupted by a space to allow for obstructions such as a chimney or roof vent. It contains the hardware needed to space around any width obstructions by connecting appropriate lengths of PVC pipe to the pipe adapters at the inlet and outlet headers of the two collectors on either side of the obstructions. Use when required.

Part No	Qty 1 1/2"	Qty 2"	Description
10008-1	1	—	Outlet header hold-down bracket assembly
10008-2	—	1	Outlet header hold-down bracket assembly
10011	4	4	Hold-down strap clamp assembly
30089-1	4	—	Pipe adapter
30089-2	—	4	Pipe adapter
50006	2	2	Hold-down strap bracket
60648-1	2	—	Collector connector hose (3 3/4" long)
60648-2	—	2	Collector connector hose (3 3/4" long)
60546-1	4	—	Hose clamp, stainless steel
60546-2	—	4	Hose clamp, stainless steel

⑥ Double Hole Outlet Header Bracket (Part #50069) may also be used to terminate a strap run in high wind areas where extra hold-down strength is required.

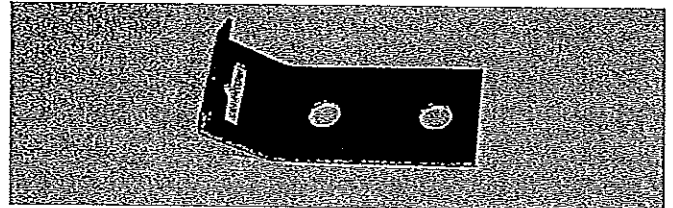

⑦ Aluminum Mounting Bracket & Header Clamp Assembly

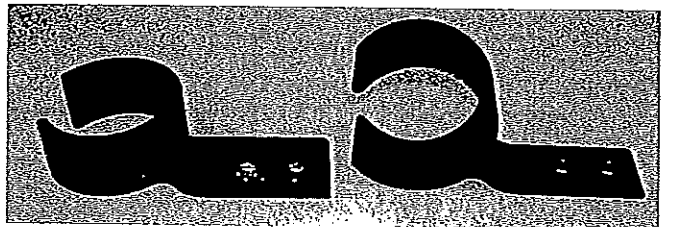

The Aluminum Header Clamp Assembly (Part #30171-1 for 1 1/2" only) is used as supplemental outlet header mounting in conjunction with the Outlet Header Hold-Down Bracket assembly (Part #10008-1). The bracket is designed for installations that require more flexibility for the outlet header mounting hardware location, such as barrel tile roofs or installations that require additional mounting hardware to be anchored into rafters or beams.

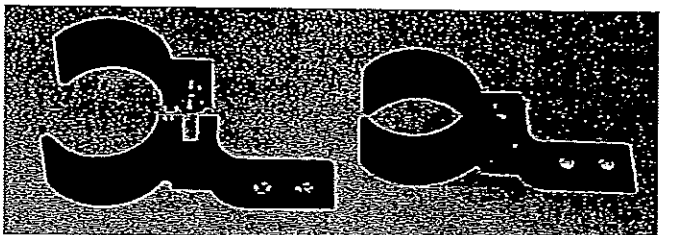

The Aluminum Header Clamp Assembly (Part #10117-1 for 1 1/2"; #10117-2 for 2") is used the same as the Aluminum Header Bracket (Part #30171-1) and allows for collector replacement without disturbing the roof penetrations.

⑧ Header Inserts (Part #50055-1 for 1 1/2"; #50055-2 for 2") are used in special situations where unusually high stagnation temperatures are expected, such as in a desert climate or where abnormally high system pressures may occur. Use four (4) inserts per collector.

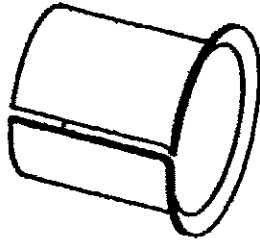

⑨ The Optional Supplemental High Wind Area Collector Hold-Down Kit (Part #12035-1 for 1 1/2", #12035-2 for 2") used in addition to the basic collector installation kit in regions where high winds are prevalent. Requires twice the amount of hold-down strap.

MOUNTING THE SOLAR COLLECTORS

Refer to Figure 1 throughout this section. When mounting the collectors, always make provisions for inlet connections at the bottom header and outlet connections at the top. The outlet headers must be pitched a vertical distance of at least 8" (20cm) above the inlet headers to assure uniform flow and proper drainage to prevent freezing. Plan the collector location to allow at least one foot on all sides of the row of collectors for mounting brackets and piping. The outlet pipe for each row of collectors must be connected diagonally opposite the inlet pipe. Refer to Figure 2.

Figure 2

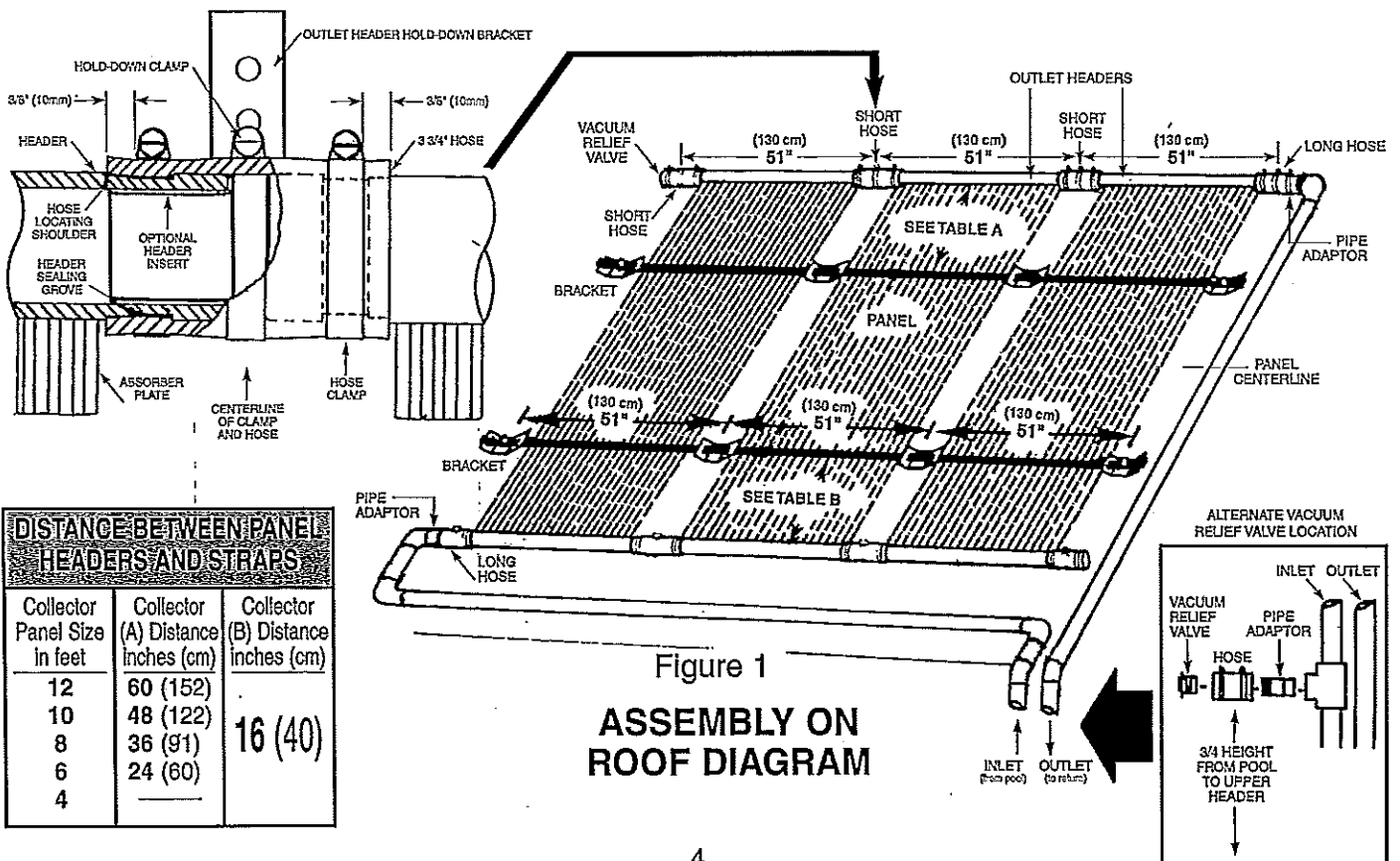
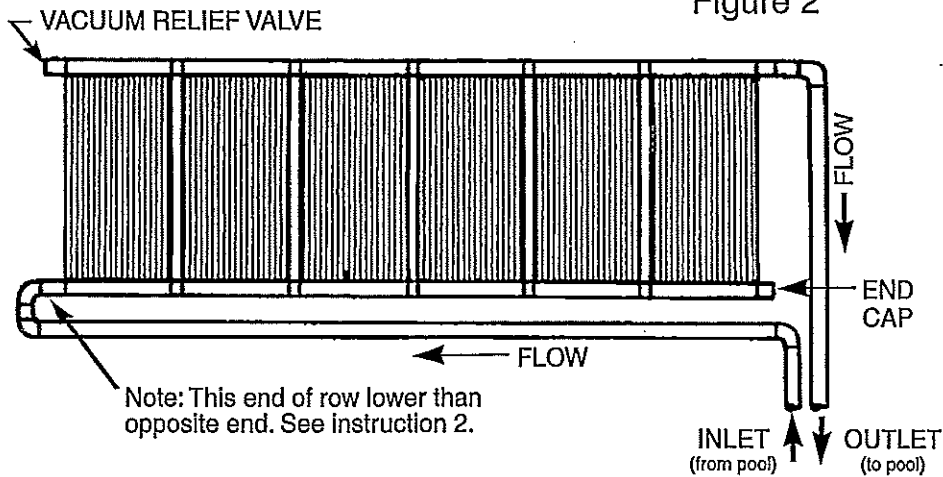

DISTANCE BETWEEN PANEL HEADERS AND STRAPS

Collector Panel Size in feet	Collector (A) Distance inches (cm)	Collector (B) Distance inches (cm)
12	60 (152)	16 (40)
10	48 (122)	
8	36 (91)	
6	24 (60)	
4		

1) Determine the position of the last outlet header hold-down bracket for the row of collectors. Mark this point on the roof. The collector outlet headers will be located approximately 1" (25mm) below this mark. Refer to Figure 3.

Figure 3

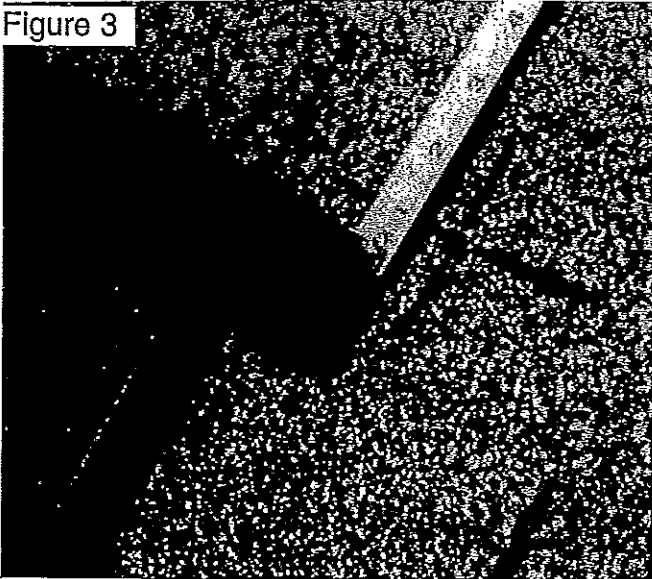

2) Using this point, snap a chalkline to the opposite end of the row. Slope this line down the roof toward the inlet approximately 1" (25mm) for each 6 collectors in the row. Using a 1/8" (3mm) drill bit (for 1/4" (6mm) diameter screws) drill a hole for the first outlet header bracket on the first roof mark. Measure up 1" on center from the first pilot hole and drill pilot hole for second screw. Repeat this process all along the chalkline for the total number of collectors to be installed.

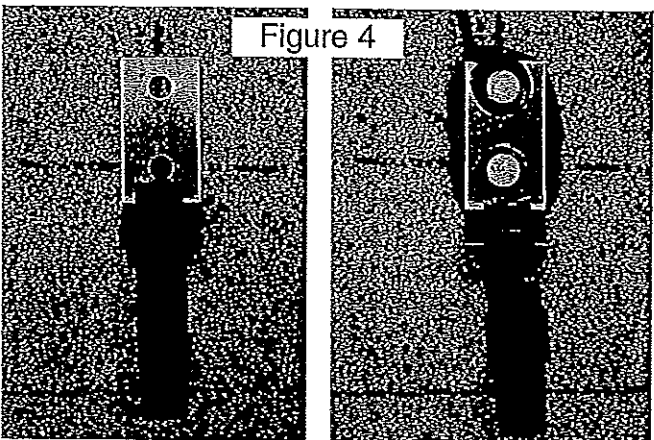
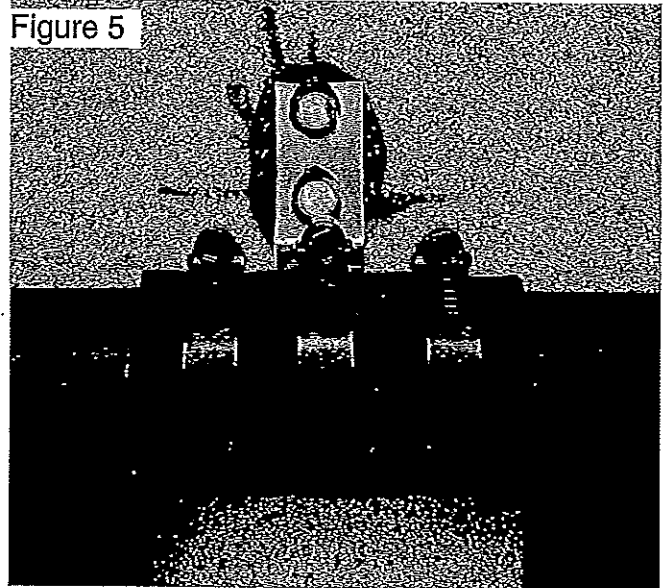

Figure 4

3) Inject a generous amount of high quality sealant into each hole and onto the surrounding roof surface. Bolt all the outlet header hold down brackets to the roof as shown in Figure 4.

4) Locate the hold-down strap bracket holes using the information in Fig. 1, Table A. Measuring from the top

Figure 5



outlet header bracket chalk line, snap another chalk line parallel to this line using the "A" dimension. The "B" dimension is the same for all collector sizes, which is 16" (40cm) up from the outside of the bottom header and can be measured after the collectors are installed. Wait to install the hold-down strap brackets until after the collectors are installed so as not to damage the collectors when you are bringing them to the roof for installation.

5) Bring the first collector to the roof and slip the proper hoses over both ends of the inlet and outlet headers on the last return collector. Make sure that the side of the collector with the serial number label on it is facing down. The long hoses go on the outlet of the last collector and the inlet of the first collector. Push UP TO the hose locating shoulder, but NOT OVER it. Locate a hose clamp 3/8" (10mm) from the end of the hose in order to center it on the header groove. This clamp must face up so as to be accessible for tightening and will not rub against the mounting surface. Make sure you securely tighten each clamp with a nutdriver. If a nutdriver is not available, a 'hex' wrench or screwdriver will suffice. THE HOSE CLAMPS MUST BE LOCATED OVER THE GROOVES IN THE HEADER.

6) Position the collector on the roof so that the center of the outlet connection hoses are directly beneath the secured outlet header brackets and slip the bracket hold-down clamps over the connection hoses. Lightly tighten the clamp around the header hose. Refer to Figure 5. Continue to install all the collectors in the array, coupling them side to side.

7) If the Aluminum Header Clamp Assembly is to be used for supplemental mounting hardware, install them after both the outlet header brackets and the collectors have been installed.

7) Proceed to the lower chalk line previously snapped on the roof for the hold-down strap brackets. Mark a hole 2" (5cm) to the side of the first collector and continue marking holes on the chalkline centered exactly between the absorber surfaces until you reach the last collector. Mark the last hole the same 2" (5cm) to the side of the last collector. Drill a pilot hole and apply sealant at each of these locations. Bolt the hold-down strap brackets on the roof. Refer to Figure 6. It is OK to step on the collectors as long as you stay one foot away from the top and bottom headers. Mark the holes for the bottom hold-down strap by measuring up 16" (40cm) from the outside of the bottom header and again centering them between the absorbers and 2" (5cm) away from the first and last collector.

Figure 6

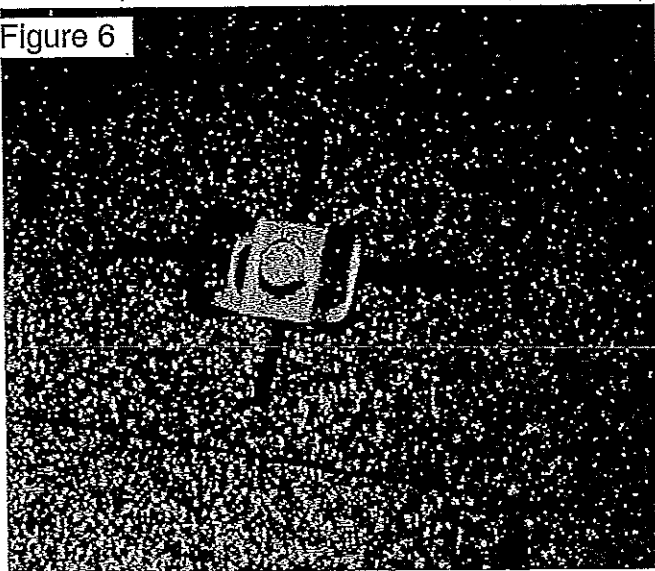

Slip one end of a hold-down strap through the slot in the hold-down strap bracket at the end of the row, then through the strap clamp and out through the other slot in the hold-down bracket. Pull about 3" (7-8cm) of the strap through

Figure 7

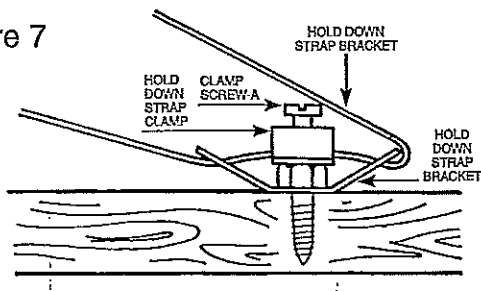

and bend it back toward the clamp. Refer to Figure 7. Slip the loose end of the strap through the strap clamp and pull it tight. Clamp screw (A) should be tightened securely, but not over-tightened to the point where the clamp is distorted. Refer to Figure 8. Bring the remaining strap end across the collector face, passing through

Figure 8

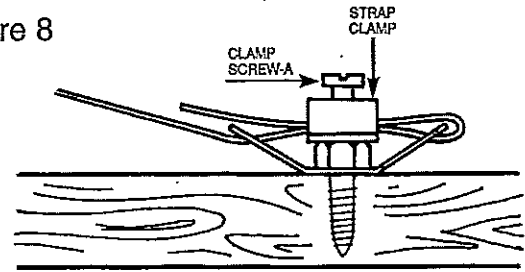

both slots in the bracket located on the other side of the collectors. Pull the straps taut against the face of the collector. Repeat this procedure for the remaining hold-down strap. Refer to Figure 9.

Figure 9

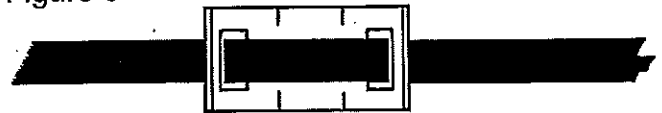

8) Install the vacuum relief valve in the outlet header of each row. This will be located at the opposite end of the row that is connected to the collector outlet pipe. Refer to figure 2, 11, and 12.

9) Install an end cap in the inlet header of each row, opposite the end that is connected to the collector inlet pipe. Refer to Figures 2, 11, and 12.

10) INSPECT THE INSTALLATION AND CHECK ALL CLAMPS FOR PROPER POSITION AND TIGHTNESS.

Installation Over Roof Vent Pipes

Collector models with intermittent sonically welded plates can be installed over or around different diameter roof vent pipes or other obstructions up to 2" (63mm) in diameter. After snapping the top chalk lines but before marking and pre-drilling for your outlet header brackets, locate the seam in the collector nearest to where the vent pipe is to come through. Separate by pulling up on top plate, and pushing down on the lower plate. Should the vent pipe protrude near a sonic tack weld, it will have to be cut apart. Using a sharp utility knife, cut through the weld while pulling the two plates apart. Lay the collector over the vent pipe, keeping the vent pipe at least 12" (30.5cm) away from a header. It will be easier to complete an installation by mounting this collector first and then working away from it.

With a roof vent pipe of 3" (8cm) in diameter, the collectors can be positioned on either side of the vent. Two system connector hoses (Part #60649-1/-2) can be employed to couple the collectors together for vent pipes or other obstacles up to 7" (17cm) in diameter. Mark your 51" (1.3m) centers wherever the outlet header brackets 'fall' on the upper chalk line. With obstructions of over 7" (17cm), such as attic fans and skylights, lay out the collectors on either side of the obstruction using a Row Spacer Kit (Part #12017-1 for 1 1/2"; #12017-2 for 2").

System Piping

Refer to Figures 10 & 11, throughout this section. The most common piping configurations use a pressure filter. The pump draws the water from the skimmer and/or a main drain, forcing it through the filter and sending it back to the pool through the return lines.

If a fuel-fired heater is installed, it is located between the filter and the return line to the pool. The pipes to and from the solar collectors are connected to the return line to the pool before the water enters the fuel-fired heater, if one is used.

Whenever there is more than 40 gpm (151.6ℓ) required flow rate to the collectors or more than 100' (12m) of piping used in a system, install 2" (63mm) piping to and from the collectors.

Piping to and from the collectors should be the same type of plastic piping and fittings approved for use with swimming pool filters and pumps. It is recommended to always use Schedule 40 PVC pipe and fittings. Although PVC pipe is generally white, black is also available but may be difficult to find locally. If for aesthetics black pipe is desired it can always be painted black. Use a PVC cutter or a PVC wide-blade saw (not a hacksaw) for cutting pipe. It is important to use both a quality cleaner/primer and solvent in gluing a PVC joint. For more detailed information on PVC gluing refer to Engineering Bulletin No. 8701. Finally, use a cloth while either gluing or painting to keep the job a clean one. Piping should also be supported at intervals of 5' (1.5m) for horizontal pipe and 8' (2.5m) for vertical pipe. Use either galvanized or plastic pipe clamps. Aquatherm Industries outlet header bracket assemblies (Part #10008-1/-2), which are made of stainless steel, are also excellent pipe hangers.

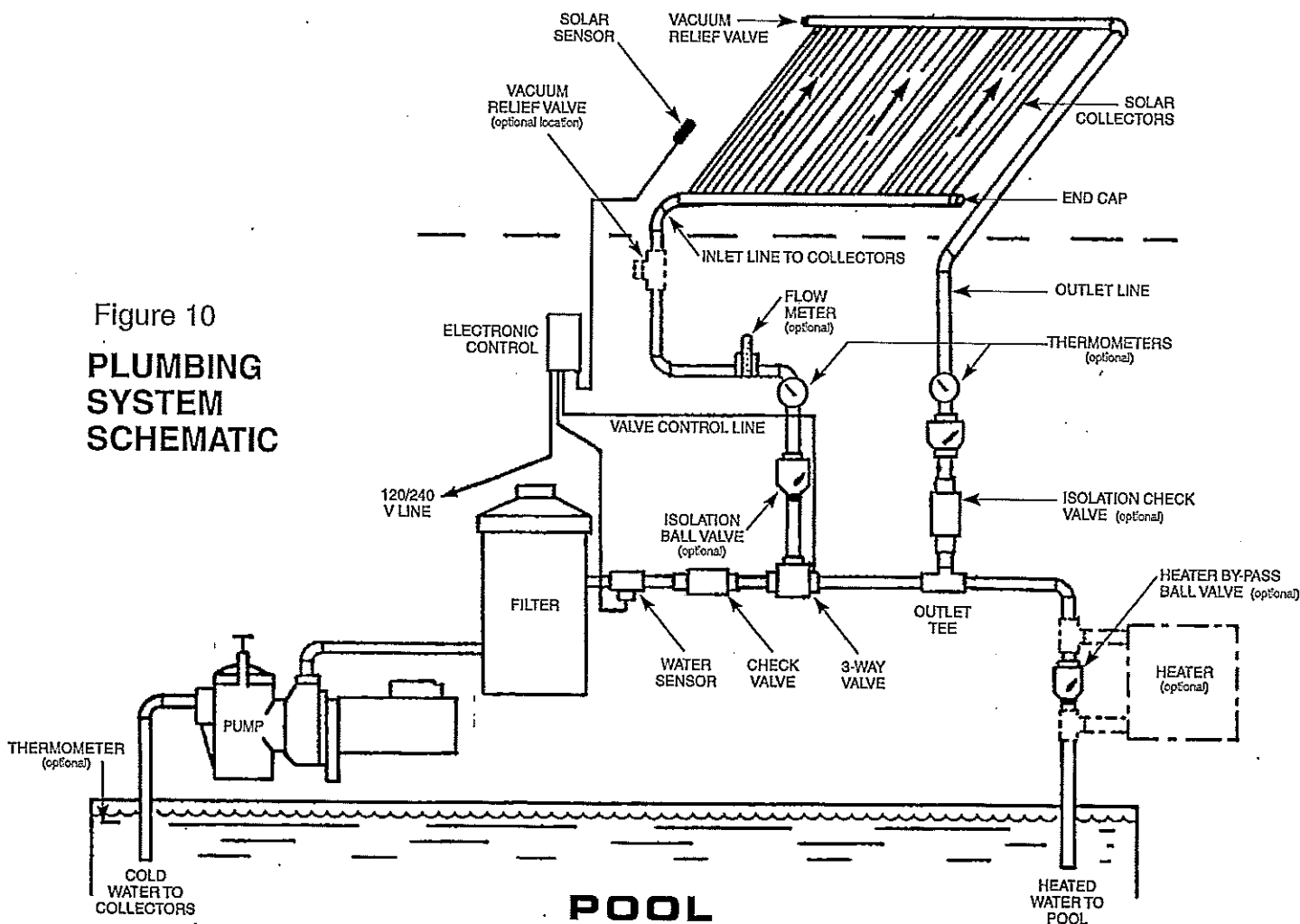

Figure 10
PLUMBING
SYSTEM
SCHEMATIC

Manual Systems

Some systems can employ a manual control valve to control the flow of water thru the solar collectors, although this may reduce the overall heating capacity of the system. The manual control valve usually consists of a non-positively sealed 3-way valve as shown in Diagram 10. Water continuously flows through the solar collectors when the filter pump is on, but can be diverted manually by the pool owner if the pool becomes too warm or during extended cloudy weather. During a threat of freezing conditions it can also be diverted, by first shutting off the pool pump, allowing the collectors to drain, diverting the 3-way manual valve to the "bypass collector" position and shutting the isolation valves on the collector feed and return lines. A lower end cap on the collector's or any of the connecting hoses can be removed to make sure there is no standing water in the collectors. The filter pump can then be restarted to allow for normal pool filtration.

During normal operation of the system when the 3-way valve is in the 'bypass collector' position all the water in the collectors should drain back through the 3-way valve (non-positively sealed) when the filter pump shuts off. An alternate way to protect against sudden freezes can be accomplished by running a bypass line (1/8"-1/4", 3-6mm) between the collector feed and return line above the isolation valves, if any. It is possible that a small amount of water may be present in the collectors when a non-positively sealed 3-way valve is used and the filter pump is on. If a positively sealed 3-way valve is used, a bypass line as mentioned above is mandatory to allow for collector drainage.

AUTOMATIC CONTROL SYSTEMS

The performance of a solar pool heating system can be improved with the use of an electronic control and motorized 3-way valve. The control activates the motorized valve and either sends water thru the collectors for heating (or nocturnal cooling) or automatically bypasses the collectors when the pool is warm enough or insufficient sunlight is available. Refer to the manufacturer's instructions included with the automatic control you use.

Other Equipment

Some pools employ an automatic pool cleaner. This should be plumbed before the control valve to assure positive flow to the cleaner at all times. If the pool uses an automatic chlorinator, this should be plumbed after the outlet tee on the return to the pool.

Flow Rates

In order to receive optimum results from Aquatherm Industries collectors, the following recommended flow rates and number of collectors per row should be followed. When the system is running, all the collectors should feel

Table B

	COLLECTOR SIZE		
	4x12	4x10	4x8
Recommended flow rate per collector, gpm/ℓ	5.0/18.9	4.0/15.1	3.25/12.5
Minimum flow rate per collector, gpm/ℓ	3.0/11.4	2.5/9.5	2.5/9.5
Maximum # collectors per row	10	12	14

uniformly cool to the touch, and there should be no residual air left in the pool return lines. If either of these two conditions persist, chances are that the flow rates thru the collectors are inadequate or the system is not properly balanced. A flow meter can be installed in the collector feed line to check on the flow rate. If the flow rates are within the limits as shown in Table B, then the systems may not be properly balanced, especially with systems requiring multiple banks of collectors. Refer to the following section on Special System Layouts.

If the flow rate is below the minimum as shown in the table above, then the pool pump horse power or pipe size should be increased, or a booster pump installed in some cases. If the long hoses on the inlet and outlet piping connections "suck in", then slip a piece of 1 1/2" (50mm) pipe into the hose to prevent this. And also, if the flow rate is excessive (more than 10 GPM/(37.9ℓ collector), or if the system pressure is greater than 30 psi, a bypass line should be installed between the collector feed and return lines above the 3-way valve to prevent problems with the collectors and connection hoses.

If there is residual air in the pool return lines and the collectors do feel cool to the touch, refer to the section concerning the vacuum relief valve test on page 10.

Optional Isolation Valves

Isolation valves may be installed in the collector piping so that the pool may be operated while the collectors are being serviced or during freezing weather. Install a manually operated ball valve in the collector inlet line and a check valve on the collector return line. Both valves, available in the **Optional Supplemental System Isolation Kit (Part #12033-1)** are made to accept either 1 1/2" or 2" PVC pipe. Make sure that the arrow on the check valve is pointing away from the collectors, and that the ball valve and check valve are located close to the control valve and outlet 'T', respectively. For further precautions in warm climates where pools are operated year round and periodic freezes can occur, a bypass line (small diameter tubing) can be located above the ball and check valve so as to prevent any accidental trapping of water in the collectors by the pool owner. To make sure no water is left in the collectors for servicing or during freezes, remember that the pool pump should be shut off, allowing the collectors to drain naturally, before the optional isolation valves are used.

Special System Layouts

Use a divided system when installing more than the recommended maximum number of collectors per row, when avoiding roof obstructions, or where limited space dictates. This provides uniform distribution of water through all the collectors. If water distribution through the collectors is non-uniform, the heating capacity of the system will be reduced.

WHEN INSTALLING A DIVIDED SYSTEM, THE OUTLET HEADERS FROM EACH OF THE LOWER (OR CLOSEST) ROWS OF COLLECTORS MUST BE CONNECTED TO THE HIGHEST (OR FURTHEST) POINT IN THE SYSTEM. Refer to Figure 11.

A divided system requires an **Add-A-Row Kit** (Part #12043-1/-2) for each row of collectors.

A more complex divided system is shown in Figure 12. This also illustrates the application of the Row Spacer Kit to clear a roof obstruction.

Booster Pump System

In some cases, the pool filter pump may not be able to circulate water at a high enough flow rate to allow for proper collector operation. If so, it may be necessary to replace the filter pump with a larger one or add a booster pump. If the pump size is increased, it may also be necessary to upgrade the filter with one with greater flow ratings.

Supplemental Gas, Oil-Fired, or Electric Heaters

It is desirable to pipe the stand-by heater in a bypass loop. Refer to Figure 10. Fuel-fired heaters often create a large pressure drop. By placing a heater in a by-pass

loop, pump size, and electrical energy requirements may be reduced.

SYSTEM START-UP AND TEST

System Start-up and Checkout for Automatic Systems

To check out the system for proper operation turn on the filter system. Set the temperature control to its highest level. Switch the control to the "flow through collector" mode. The "flow through collector" light should come on. The 3 way valve will then be sending water thru the collectors, and air will be purged out of the collectors into the pool return line for several minutes, and should then clear. The collectors should feel uniformly cool to the touch. Switch the control to the "bypass collector" mode. The corresponding light will go on and the 3 way valve will be sending water directly back to the pool, bypassing the solar collectors. After about 5-10 minutes, feel the solar collectors again. They should have begun to warm up. Now switch back to the automatic mode. If the sun is still shining on the solar collectors, the "flow thru collector" light should go on again. Adjust the temperature control lower.

When you reach the actual temperature of the pool water, the light will turn off. The flow bypass collector light will go on again. Move the temperature control to maximum and leave there. The "flow through collector" light will go back on. For more detailed information on the system startup, trouble shooting and valve/control installation, follow the manufacturers' instructions included with the automatic control system.

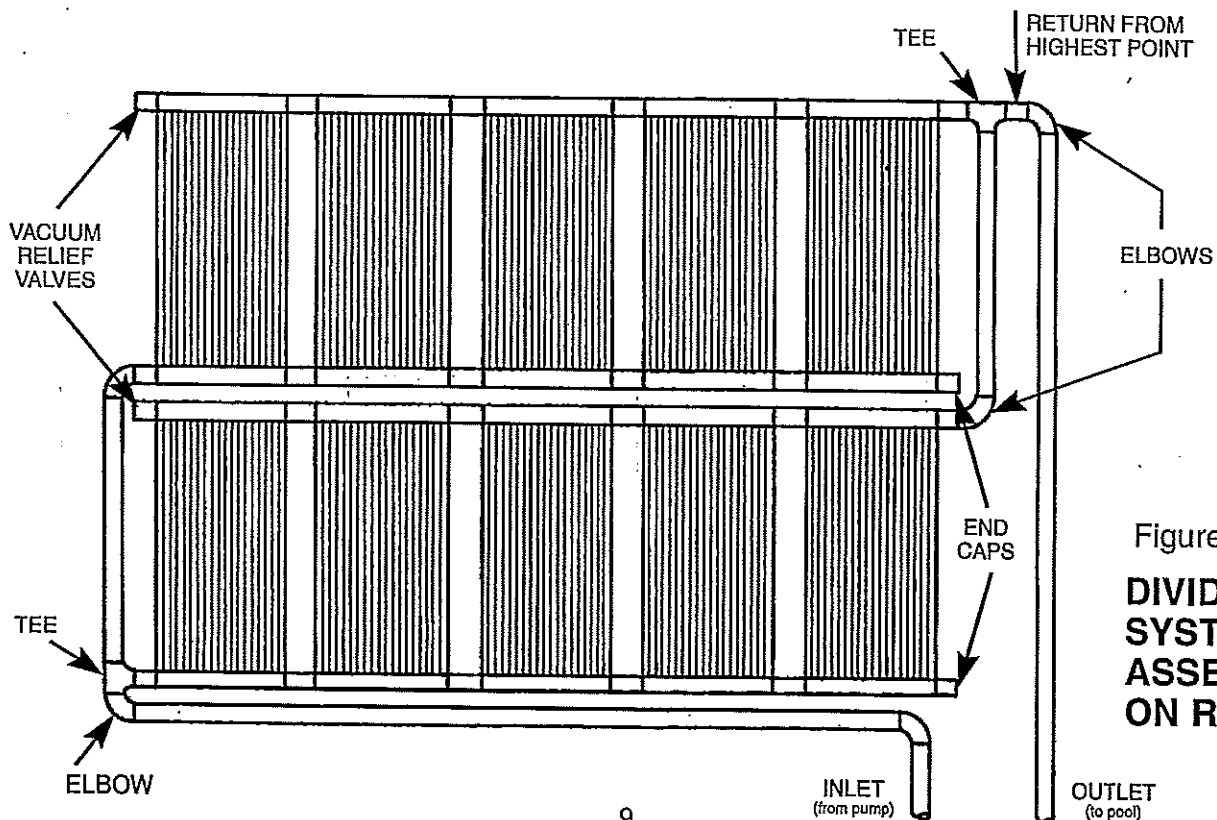
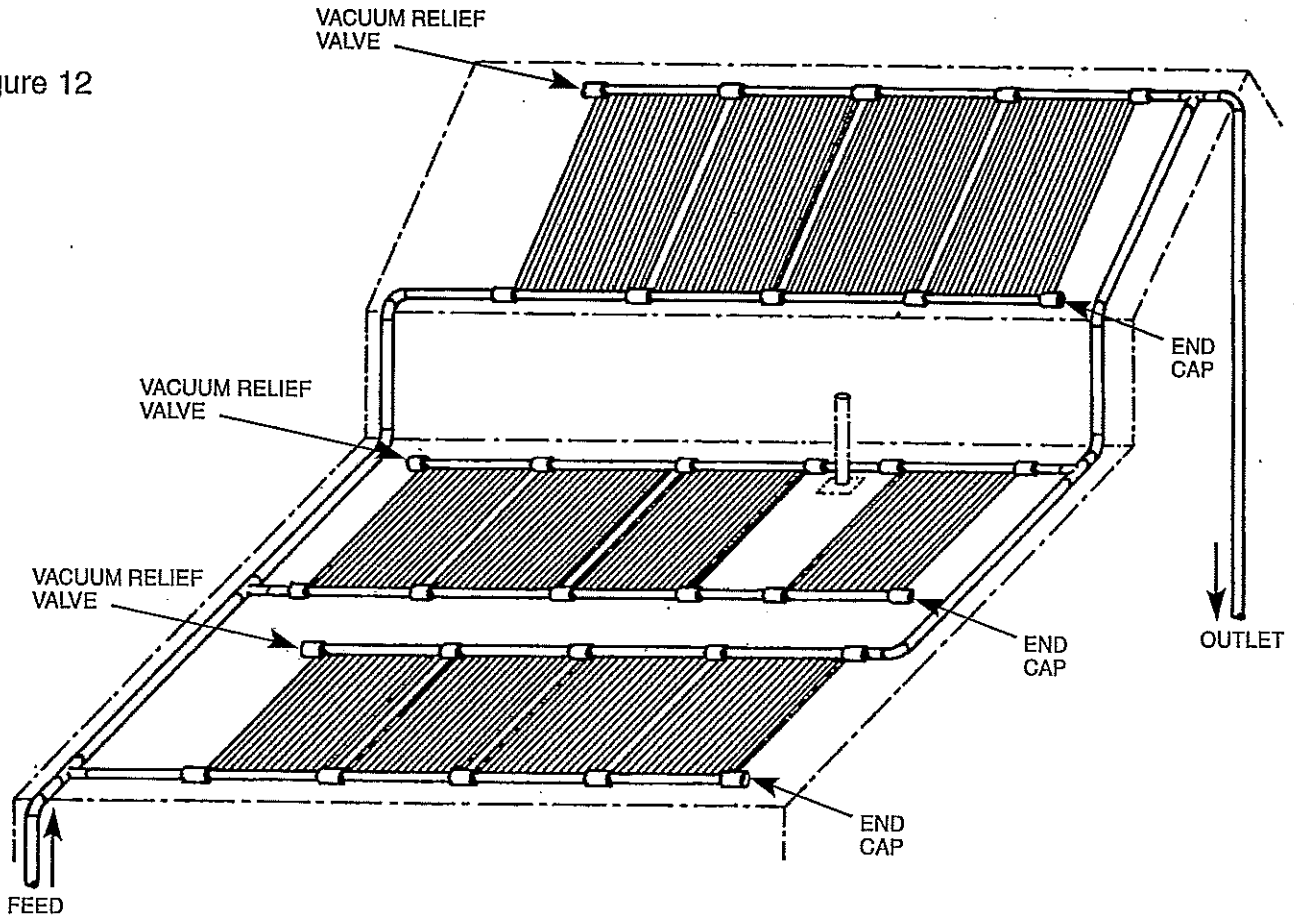

Figure 11
**DIVIDED
SYSTEM
ASSEMBLY
ON ROOF**

Figure 12



Manual Control of System

To test collector operation, follow either the flow-rate or temperature-rise procedure. Divert water through the collectors. Turn on the pump and either observe flow rate or temperature rise. The flow rate or temperature rise would be the same as that specified in the "System Start-Up and Test" section. If it is not, then check for the indicated probable causes and make necessary corrections.

Flow Rate Test Method

The preferred system test method is flow rate. This is also the easiest and quickest method. To check flow rate, install a flow meter in the inlet line to the collectors (follow installation instructions provided with the flowmeter).

Temperature Rise Test Method

An alternate test method is temperature rise. To prepare the system for testing, obtain two accurate thermometers. Aquatherm Industries dial thermometers (Part #60054-2) are excellent for this application. One of these thermometers is installed in the outlet line from the collectors as shown in Figure 10. The other is used to check the temperature of the pool water, to compare it with that of the water leaving the solar collectors. Before installing the thermometer in the outlet line, immerse both thermometers in the pool water for several minutes to compare the temperature readings. If they are not identical,

make a notation of the difference and add or subtract (as appropriate) this difference to or from the reading taken while you are testing. This is necessary in order to provide an accurate indication of the temperature rise of the water passing through the solar collectors.

Turn the pump on and move the flow switch to the "COLL" position. Observe valve action...it should divert water through the collectors. After flow through the collectors has continued for a least fifteen minutes, compare the pool water temperature with the temperature of the water flowing through the outlet line. On an average sunny day, with the air temperature approximately 70°F (21°C) the water leaving the collectors should be 1 to 7°F (1 to 4°C) higher than that in the pool. If the water rise is greater than this, insufficient water is flowing through the collectors. This may be caused by a clogged filter, undersized piping, to many elbows in the piping or an inadequate pump. **It is important that the temperature rise through the collectors be kept as low as possible in order to deliver the maximum amount of heat to the pool.**

Vacuum Relief Valve Test

When the solar system is first turned on, air in the collectors will be expelled into the pool and bubbles will appear. The appearance of bubbles in the pool should stop after a few minutes. If, after a few minutes, bubbles continue to be discharged at the return to the pool, remove the vacuum

relief valve(s) and replace it with an end cap. Relocate a vacuum relief valve to a position in the inlet piping which is at a height of approximately three-fourths of the elevation of the collectors above the pool. Refer to Figure 1.

(A quicker alternate method is to first try to reverse the end cap and the vacuum relief valve on the collector array to see if this stops the bubbles in the return lines. Sometimes the end cap is about 3/4 of the elevation of the collectors and this is a lot quicker than cutting in a tee in the supply pipe.)

MAINTENANCE

Winterizing Procedures

The solar collectors should drain automatically each time the pump cycles off. There are no special requirements for winterizing the solar collectors. The pool piping should be winterized as per your normal practice. In southern parts of the country pool owners operate their pools throughout the winter although light freezing conditions may occur. The accepted procedure for avoiding freezing of the pool piping and filtration system has been to continuously circulate the water. When solar heaters are used on a pool under these conditions, anti-freeze precautions should be taken. In order to protect the collectors as well as appurtenant components such as end caps and pipe fittings and against unusual or severe freezing conditions, one of the following two procedures should be followed when freezing weather is imminent.

1. Turn circulating system off and allow solar collectors and piping to drain. Isolate collectors with gate or ball valve in collector feed line and a check valve in the collector return line. Switch the solar control to the bypass position. The pool filtering system may then be turned back on. When freezing conditions have passed, open isolation valves and switch the solar control to "AUTO".

2. Switch the solar control to the "COLL" position so that water circulates through the collector. When freezing conditions have passed, switch the solar control to "AUTO". THIS METHOD IS NOT RECOMMENDED WHERE TEMPERATURE LEVELS MAY DROP SEVERELY.

Annual Service Collector Clamps:

In particularly hot climates, such as Arizona and Southern Florida, the clamps which are used to connect the solar collectors may become loose. If you notice leaks around the hose couplings, use a nutdriver to tighten clamps. Do not tighten to the extent that the pipe collapses or the clamp gears strip. In areas where unusually high stagnation temperatures are prevalent or where abnormally high system pressures occur, use header insert (Part #50055-1/-2).

COLLECTOR REPAIR

This method allows for an easy and permanent on site repair of a collector by isolating the leaking riser tube. Referring to the figure below, locate the tube to be isolated. (End tube has been shown for clarity.) Using a sharp utility knife, very carefully cut away approximately 1" of the tube at both headers. Drive a #10 - #12 sheet metal screw, preferably stainless, into the hole in the header. The screw must be between 1/2" and 3/4" long. DO NOT OVERTIGHTEN! If the screw strips out, or if the repair leaks, use a larger screw. This repair method will not void the collector warranty.

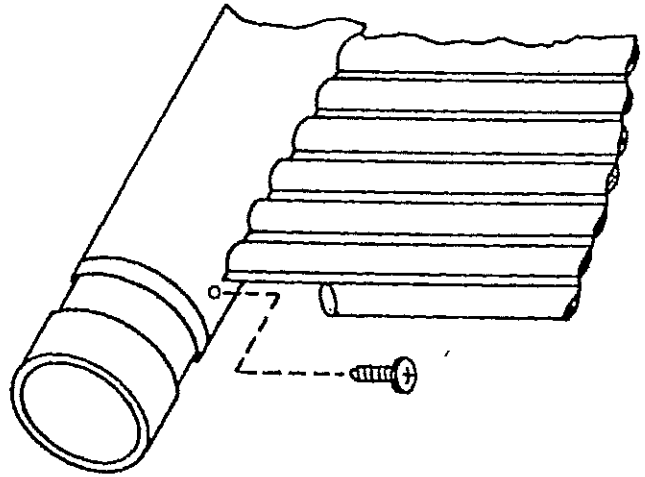
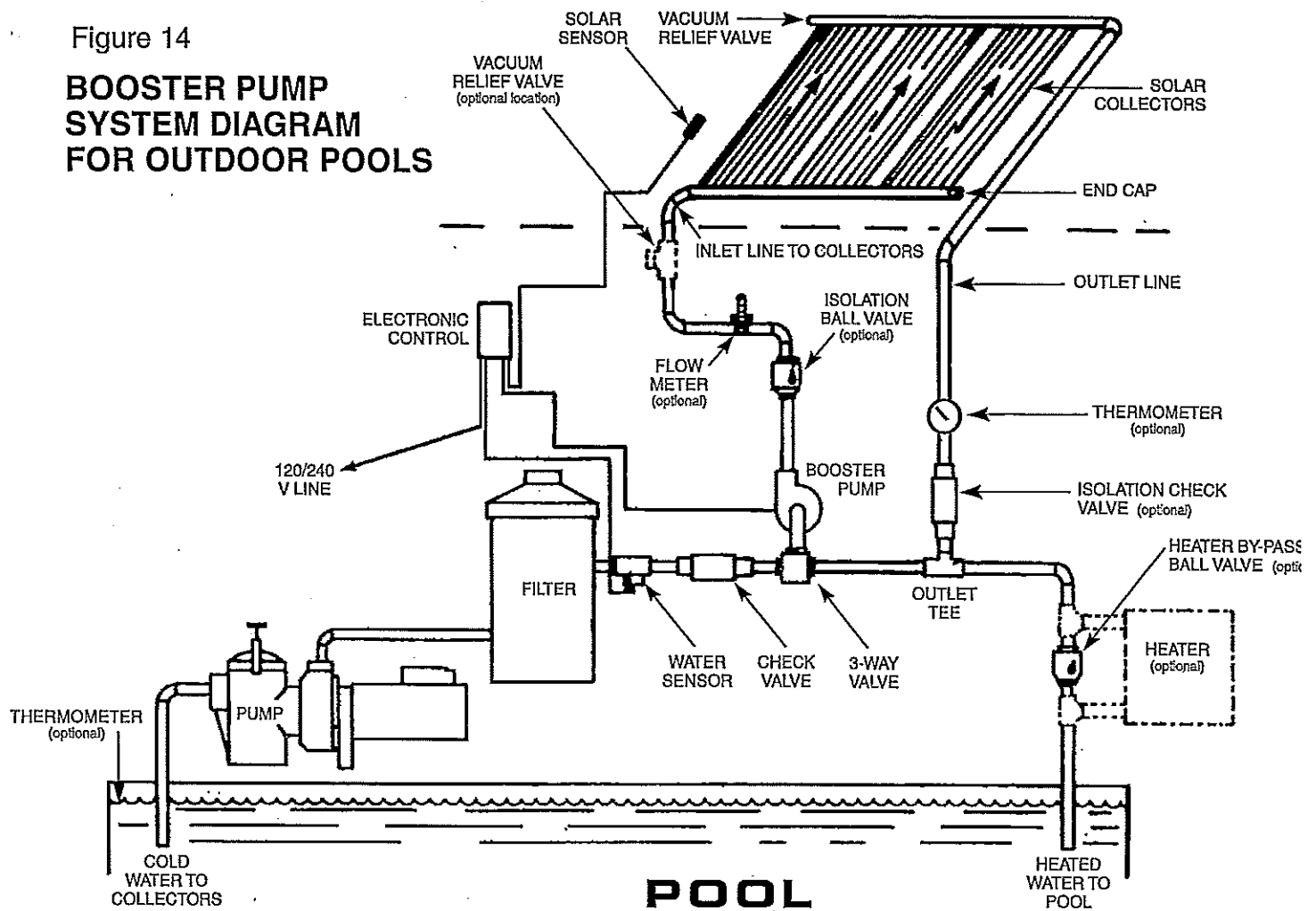

Figure 14

BOOSTER PUMP SYSTEM DIAGRAM FOR OUTDOOR POOLS



1940 Rutgers University Blvd. • Lakewood, New Jersey 08701 • 1-732-905-9002