

# FACTORY REBUILD KIT

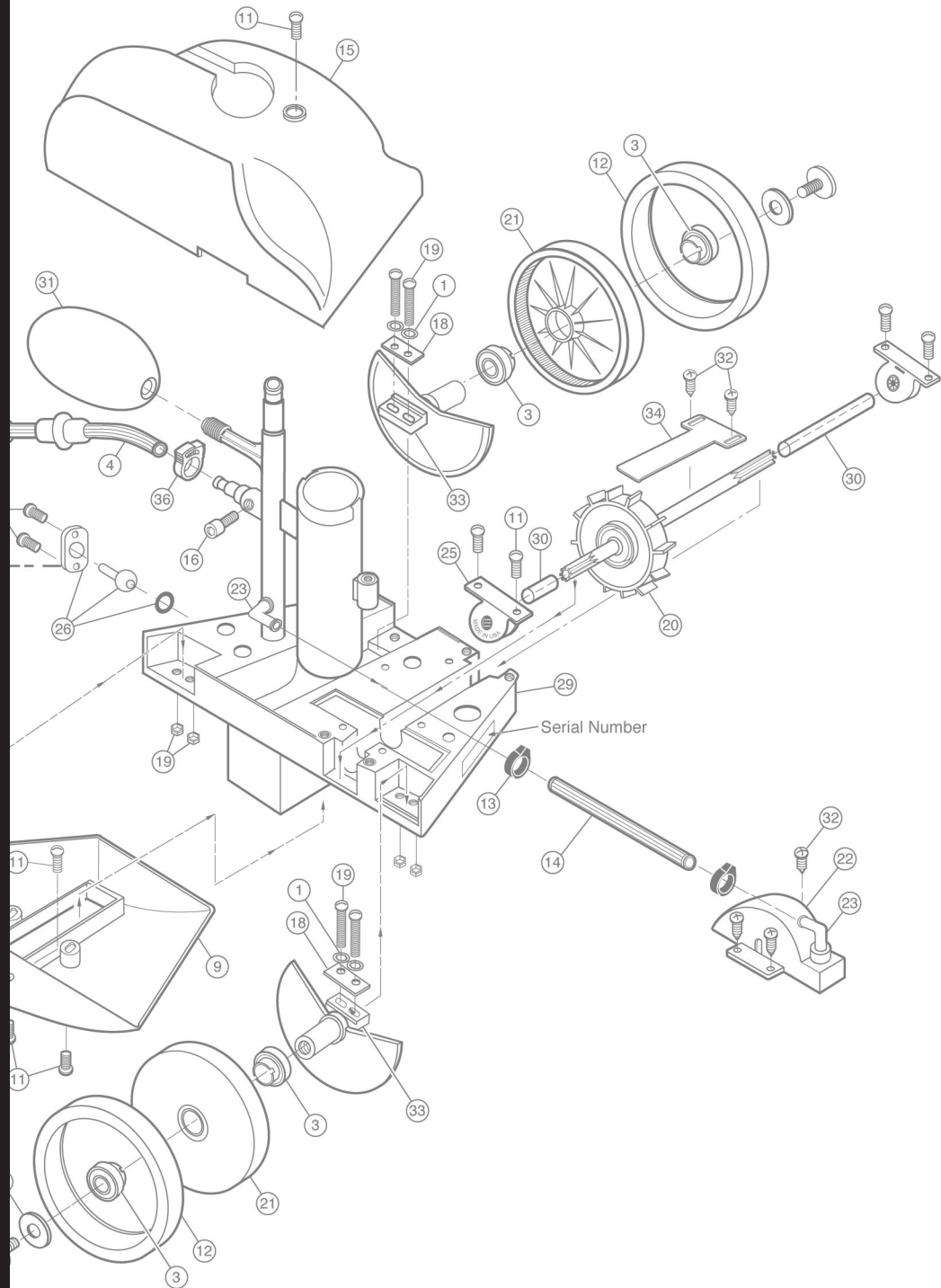

 **Polaris180**

INSTALLATION INSTRUCTIONS

## Tools Needed:

Philips screwdriver

Needle nose pliers

Small flathead screwdriver

## Disassembly

1. Mark the position of the head float on the feed mast. Remove and discard the head float.
2. Remove and discard the bag, sweep hose, and attach clamp. Remove and retain the sweep hose adjustment screw.
3. Remove the blue top and discard. Retain the screw.
4. Label the single-side wheel and the front double-side wheel so that once removed you can tell them apart. Remove the axle screws and the wheel assemblies for the three large wheels. Set the screws and axle plates aside for reassembly.
5. Remove the clamps and turbine hose from the feed mast elbow and discard. Remove the turbine cover. Set the screws and turbine cover aside for reassembly.
6. Remove the turbine shaft shield. Retain the shield and screws.
7. Remove the two turbine bearings, drive shaft assembly, and turbine shaft tubes. Retain the screws.
8. Remove and discard the bottom and idler wheel. Retain the screws.
9. Remove and retain the six loose axle block nuts. If they are not in the bottom, they are still in place in the frame.
10. Remove the thrust jet kit (2 screws, plate, thrust jet and o-ring). Retain the screws.

## Reassembly

**Please note: Do not over tighten the screws, they only need to be installed hand-tight.**

1. Install the new thrust jet kit (o-ring, thrust jet, plate and screws). Position the thrust jet straight back and tighten screws.
2. Place the new turbine bearings and drive shaft assembly into position and replace the four screws. **Please note: Do not remove the clear covers on the drive shaft, they are designed to ensure proper turbine spacing.**

3. Reinstall the turbine cover using three of the screws. Attach the new turbine hose to the feed mast elbow and turbine cover. Install a new hose clamp at each end of the hose. Pull the clamp tight and cut off the excess length.
4. Using two screws, reinstall the turbine shield. Note: The lip on the turbine shield goes under the turbine cover.
5. Lay the old front double-side wheel next to a new wheel/sand guard assembly. Point the axle on each wheel in the same direction (see drawing). Use needle-nose pliers to remove a notch from the new wheel in the same place as the old wheel.

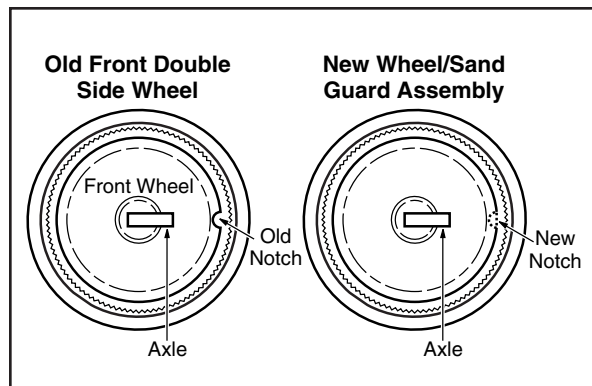

6. Install the new front double-side wheel with the axle plate, lock washers, and screws. Make sure the grooves in the axle line up with the ribs on the frame. Leave the screws loose enough to adjust the wheel position.
7. Adjust the wheel so the spline of the drive shaft assembly engages 3/4 of the wheel gear teeth (see drawing). It is easier to see

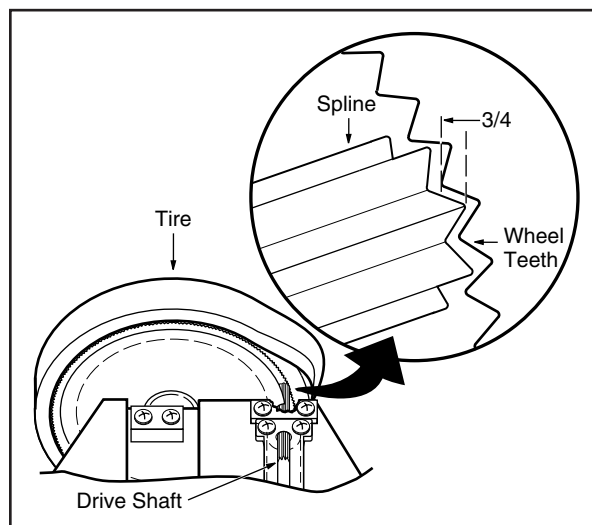

the engagement if you peel back the tire. To test the wheel placement, spin the wheel; it should spin freely. Also, hold the wheel and quickly rotate it back and forth. The gears should not slip or chatter.

8. Repeat steps 5-7 for the single-side wheel.
9. Align the threads on the frame and install the rear wheel assembly (this wheel does not have a sand guard) using the axle plate and lock washers. The longest part of the wheel axle should point toward the rear of the cleaner. Leave the screws loose enough to adjust the wheel position.
10. Install the new idler wheel onto the swing axle on the bottom. Use the new wheel washer and plastic wheel screw. Do not overtighten the screw; the wheel should spin freely.

11. Install the new bottom with idler wheel onto the frame.
12. Slide the rear wheel forward until it just contacts the idler wheel and tighten the axle block screws. When you spin the rear wheel, it should slip slightly against the idler wheel. When you spin the front wheel, all the wheels should spin freely.
13. Install the new blue top. Do not overtighten the screw.
14. Screw the sweep hose adjustment screw into place. Attach the new sweep hose with the attach clamp.
15. Position the new head float to the mark on the feed mast.
16. Attach the new all-purpose bag.

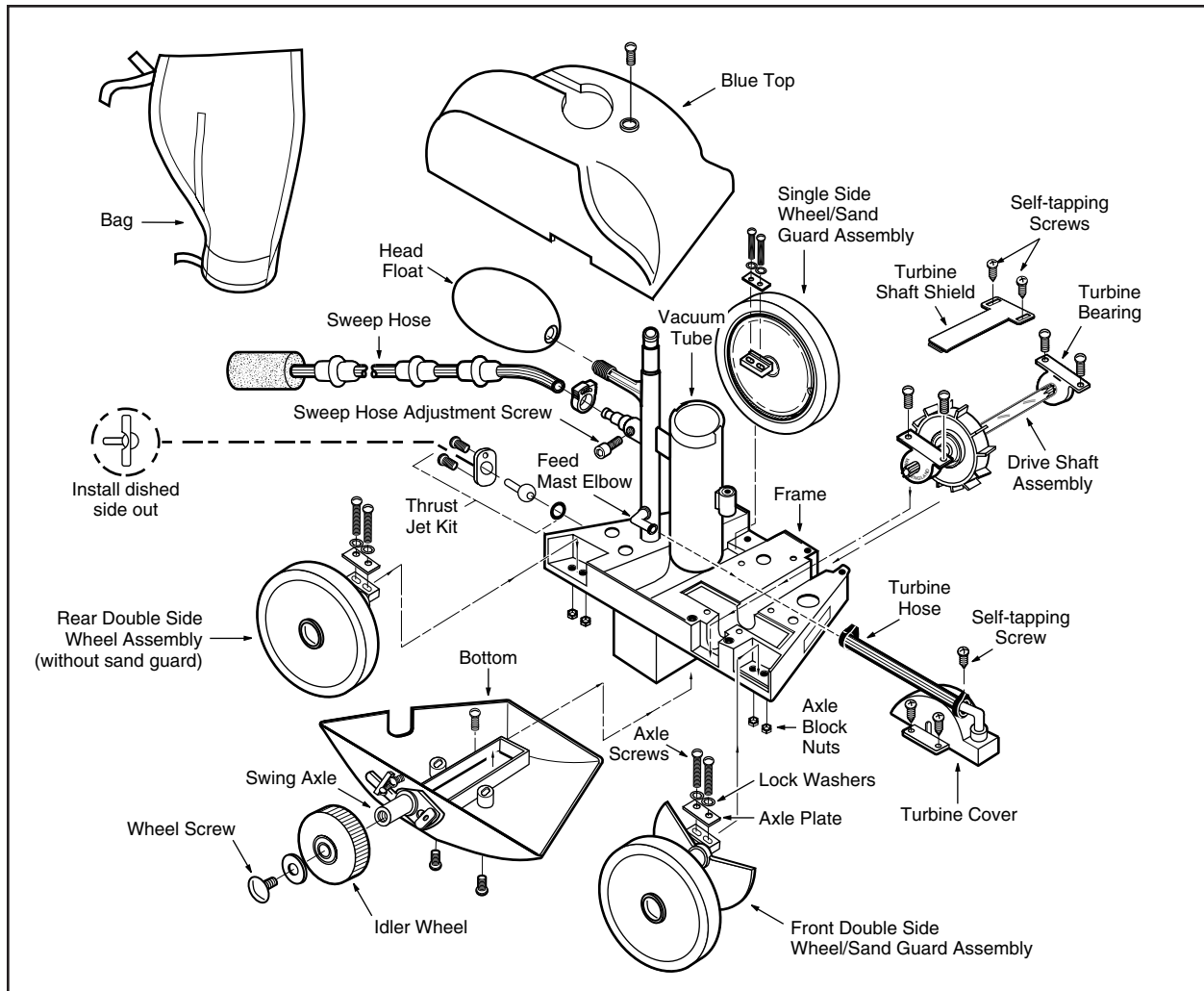

**If you have any additional questions, please contact our Customer Service Department toll-free at 1-800-VAC-SWEEP.**

## Limited Warranty Polaris 180 Factory Rebuild Kit

This limited warranty is extended to the original consumer purchaser of this Polaris 180 Rebuild Kit manufactured by Polaris Pool Systems, Inc., 2620 Commerce Way, California 92081-8438, USA. This warranty is in effect only if a pool professional installs this kit and a completed warranty registration card is received at Polaris.

Polaris warrants the parts in this kit to be free of defects in material and workmanship. We do not cover bags, tires, sweep hoses, or sweep hose scrubbers which have been worn out by use. These are normal replacement items. We do not cover damage caused by improper installation of the parts in the Rebuild Kit. If you have a question regarding your Polaris 180 Rebuild Kit or your Polaris Vac-Sweep 180 Cleaner, please feel free to call or write us. Be sure to provide the serial number, which can be located on the rear of the frame of your unit.

EXAMPLE: C 1 2 3 4 5 6

The Polaris 180 Factory Rebuild Kit is warranted for a period of one year from date of manufacture, or one year from date of purchase with proof of purchase, whichever is later. The date of manufacture is established by the date of installation recorded on the Registration Card submitted to Polaris by your pool professional.

This limited warranty does not apply if the failure is caused or contributed to by any of the following: improper handling, improper usage, improper storage, winter freezing, abuse, improper installation, removal of the UWF filter screen, unsuitable application of the unit, improper maintenance, lack of reasonable and necessary maintenance, damage in transit or during installation, or damage from repairs/alterations made or attempted by anyone other than Polaris or one of its Authorized Service Centers. Polaris will repair or replace, at its option, a part proved to be defective within the warranty period and under the conditions of the warranty.

In order to make a claim under this warranty, the consumer must deliver or ship the unit or warranty parts freight prepaid to the nearest Polaris Authorized Service Center or return it freight prepaid (after proper authorization) to the plant of manufacture. Authorization to return a unit or parts to the plant of manufacture must be obtained from the Polaris Customer Service Department. Check with your dealer for the local procedure before exercising this warranty. If further directions or instructions should be required, contact the Customer Service Department at 1-800-VAC-SWEEP (USA and Canada only) or (760) 599-9600. Be sure you insure your shipments against loss or damage in transit.

Polaris is not responsible for the cost of removal of the unit or parts, damages during or due to removal, any other expenses incurred in shipping the unit or parts to or from the factory or its Authorized Service Centers, or damages during the installation of the repaired or replacement unit. The consumer must bear these expenses.

This warranty does not cover repair or replacement of a unit or part except at our plant of manufacture or Polaris Authorized Service Center. This warranty does not cover pattern removal, abrasion or markings on a vinyl liner.

**THIS LIMITED WARRANTY IS IN LIEU OF ALL OTHER WARRANTIES, EXPRESS OR IMPLIED, INCLUDING THE IMPLIED WARRANTIES OF MERCHANTABILITY AND FITNESS FOR A PARTICULAR PURPOSE, AND ALL SUCH OTHER WARRANTIES ARE DISCLAIMED EXCEPT TO THE EXTENT ANY IMPLIED WARRANTY MAY BE IMPOSED BY STATE CONSUMER LAW. ANY SUCH IMPLIED WARRANTY IMPOSED BY STATE CONSUMER LAW IS LIMITED IN DURATION TO ONE (1) YEAR FROM DATE OF PURCHASE.**

**IN NO EVENT SHALL POLARIS BE LIABLE FOR INCIDENTAL OR CONSEQUENTIAL DAMAGES OF ANY NATURE OR KIND OR FOR DAMAGES TO PERSONS OR PROPERTY, INCLUDING ANY DAMAGE RESULTING FROM THE USE OF THE POLARIS VAC-SWEEP 180 AUTOMATIC SWIMMING POOL CLEANER WITH A SUBSTANDARD POOL CIRCULATION SYSTEM.**

Some states do not allow limitations on how long an implied warranty lasts, or the exclusion or limitation of incidental or consequential damages, so the above limitations may not apply to you.

This limited warranty is valid only in the United States of America, Canada and Australia, and it does not apply to Polaris 180 Factory Rebuild Kits sold or installed in any other country.