



## CMARSHA SERIES SALT CHLORINATION SYSTEM



## INSTALLATION AND OPERATION MANUAL

READ AND FOLLOW ALL INSTRUCTIONS  
SAVE THESE INSTRUCTIONS

Thank you for your purchase of a CaliMar® CMARSHA Salt System. Our salt systems are designed to meet or exceed specifications, for optimal performance and reliability.

<b>CaliMar® Part Number</b>	<b>Pool Volume in Gallons</b>
CMARSHA15	15,000
CMARSHA25	25,000
CMARSHA40	40,000

### **IMPORTANT SAFETY INSTRUCTIONS**

When using electrical equipment, basic safety precautions should always be exercised, including the following:

#### **READ AND FOLLOW ALL INSTRUCTIONS**

- Disconnect all AC power during installation.
- Do not permit children to use this product.
- A green colored screw is located inside the wiring compartment, against the back panel. To reduce the risk of electric shock, this terminal must be connected to the grounding means provided in the electric supply service panel with a continuous copper wire equivalent in size to the circuit conductors supplying the equipment.
- One bonding lug for US models (two for Canadian models) is provided on the external surface. To reduce the risk of electric shock, connect the local common bonding grid in the area of the swimming pool, spa, or hot tub to these terminals with an insulated or bare copper conductor not smaller than 8 AWG US/6 AWG Canada.
- All field-installed metal components such as rails, ladders, drains, or other similar hardware located within 10 feet (3 meters) of the pool, spa or hot tub shall be bonded to the equipment grounding bus with copper conductors not smaller than 8 AWG US/ 6 AWG Canada.

# TABLE OF CONTENTS

OPERATION .....	4
WATER CHEMISTRY .....	4
CONTROLS .....	8
MAINTENANCE .....	10
INSTALLATION .....	11
MOUNTING .....	12
PLUMBING .....	12
WIRING .....	15
TROUBLESHOOTING .....	18
WARRANTY .....	20

## OPERATION

The CMARSHA is an automatic chlorine generation system for pool & spa sanitation. The operation requires a low concentration of salt (sodium chloride) in the pool water at levels low enough that it normally cannot be tasted. The CMARSHA system automatically sanitizes your pool by converting the salt into free chlorine, which kills bacteria and algae in the pool through a process called electrolysis.

CMARSHA is designed to handle the purification needs of the average residential swimming pool. The actual amount of chlorination required to properly sanitize a pool varies depending upon bather load, rainfall, air temperature, pool water temperature, pool exposure to sunlight, pool's surface, and cleanliness.

Note: It is not recommended using the CMARSHA system to generate Bromine.

If your pool has natural stone as coping or decking, please check with a stone installation specialist for the maintenance of the stone before installing the SPS.

## WATER CHEMISTRY

As with any pool, it is important that you maintain proper water chemistry of the pool water, including pH, alkaline content, and calcium levels. The only special requirement for CMARSHA is to maintain proper levels of salt and stabilizer. It is important to maintain these levels in order to prevent corrosion or scaling and to ensure maximum enjoyment of the pool. Test your water periodically. It is recommended that the pool water be professionally tested a minimum of twice per season. Your local pool store can provide you with the chemicals and procedures to adjust the water chemistry. Be sure to tell the pool store that you are using a salt chlorine generator.

### **IDEAL CHEMICAL LEVELS**

<b>Salt</b>	<b>3200 to 4000 ppm</b>
<b>Free chlorine</b>	<b>1.0 to 3.0 ppm</b>
<b>pH</b>	<b>7.2 to 7.6</b>
<b>Cyanuric Acid (Stabilizer)</b>	<b>50 to 100 ppm</b>
<b>Total Alkalinity</b>	<b>80 to 120 ppm</b>
<b>Calcium Hardness</b>	<b>200 to 400 ppm</b>
<b>Metals</b>	<b>0 ppm</b>
<b>Saturation Index</b>	<b>-.2 to .2</b>

### **SATURATION INDEX**

The saturation index (Si) relates to the calcium and alkalinity in the water and is an indicator of the pool water "balance". Your water is properly balanced if the Si is  $0 \pm .2$ . If the Si is below  $-0.2$ , the water is corrosive and plaster pool walls will be dissolved into the water. If the Si is above  $+0.2$ , scaling and staining will occur. Use the chart below to determine the saturation index.

$$\text{Si} = \text{pH} + \text{Ti} + \text{Ci} + \text{Ai} - 12.1$$

°C	°F	Ti	Calcium Hardness	Ci	Total Alkalinity	Ai
12	53	.3	75	1.5	75	1.9
16	60	.4	100	1.6	100	2.0
19	66	.5	125	1.7	125	2.1
24	76	.6	150	1.8	150	2.2
29	84	.7	200	1.9	200	2.3
34	94	.8	250	2.0	250	2.4
39	103	.9	300	2.1	300	2.5
			400	2.2	400	2.6
			600	2.4	600	2.8
			800	2.5	800	2.9

*How to use:* Measure pool pH, temperature, calcium hardness, and total alkalinity. Use the chart above to determine Ti, Ci, and Ai from your measurements. Insert values of pH, Ti, Ci and Ai into the above equation. If Si equals .2 or more, scaling and staining may occur. If Si equals -.2 or less corrosion or irritation may occur.

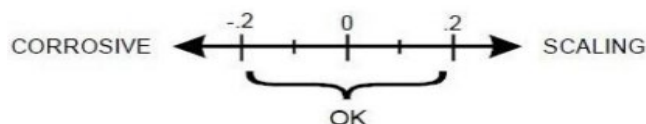

### SALT LEVEL

Use the chart below to determine the amount of salt needs to be added to reach the recommended levels. Use the equations below to determine the size of your pool.

	Gallons (pool size feet)	Liters (pool size in meters)
<b>Rectangular</b>	Length x Width x Average Depth x 7.5	Length x Width x Average Depth x 1000
<b>Round</b>	Diameter x Diameter x Average Depth x 5.9	Diameter x Diameter x Average Depth x 785
<b>Oval</b>	Length x Width x Average Depth x 6.7	Length x Width x Average Depth x 893

- The ideal salt level is between 3200-4000 ppm (parts per million) with 3600 ppm being the optimal level. Calculate the number of gallons in the pool and add salt according to the chart on page 3.
- A LOW salt level will reduce the efficiency of the CMARSHA and result in low chlorine production.
- Excessively HIGH salt levels will cause the CMARSHA to shut down, making pool water unsafe for bathers. LOW salt levels can cause the CMARSHA not to operate efficiently, causing the same

### Type of Salt to Use

It is important to use only sodium chloride (NaCl) that is 99% pure. This is common food quality or water softener salt available in 40-80 lb/bag at your local store. It is also acceptable to use water conditioning salt pellets; however it will

take longer for them to dissolve. Do not use rock salt, salt with more than 1% yellow prussiate of soda, salt with more than 1% of anti-caking additives, or iodized salt.

### **How to Add or Remove Salt**

- IN GROUND POOLS: Turn the filter pump on and add the salt directly into the pool at the shallow end.
- ABOVE GROUND POOLS WITH MAIN DRAINS: Add directly in front of the return jet to pool. Run the filter pump for 24 hours with the suction coming from the main drain (use the pool vacuum if there is no main drain) to allow the salt to evenly disperse throughout the pool.
- ABOVE GROUND POOLS WITHOUT MAIN DRAINS: Add directly into the pool. Brush the salt to speed up the dissolving process. Do not allow the salt to sit in a pile on the bottom of the pool.

ON ANY POOL, DO NOT ADD SALT DIRECTLY TO THE SKIMMERS OR DIRECTLY ONTO THE MAIN DRAIN. THIS WILL SHUT DOWN OR SHORTEN THE LIFE OF THE CELL DUE TO HIGH SALT CONCENTRATION AND REDUCED FLOW TO THE PUMP

If added incorrectly, immediately turn off CMARSHA for 24 hours with the pump and filter operating this will help to evenly distribute the salt. The salt display may take 24 hours to respond to the change in salt concentration.

### **SALT DOES NOT EVAPORATE FROM POOL**

The only way to lower the salt concentration is to partially drain the pool and refill with fresh water.

**Pounds and (Kg) of Salt Needed For 3200 PPM**

Gallons and Liters of Pool/Spa Water

<b>Current salt level ppm</b>	<b>Gallons Liters</b>	<b>6,000 22,500</b>	<b>8,000 30,000</b>	<b>10,000 37,500</b>	<b>12,000 45,500</b>	<b>14,000 37,500</b>	<b>10,000 37,500</b>	<b>10,000 37,500</b>
<b>0</b>	Gallons	180	239	301	360	419	481	540
	Liters	82	109	136	163	190	218	245
<b>200</b>	Gallons	170	226	284	340	396	454	510
	Liters	78	103	129	154	180	206	232
<b>400</b>	Gallons	160	213	267	320	373	427	480
	Liters	73	97	121	145	170	194	218
<b>600</b>	Gallons	150	200	250	300	350	400	450
	Liters	69	91	114	136	159	182	205
<b>800</b>	Gallons	140	187	233	280	327	373	420
	Liters	64	85	106	127	148	170	191
<b>1000</b>	Gallons	130	173	217	260	303	347	390
	Liters	59	79	98	118	138	158	177
<b>1200</b>	Gallons	120	160	200	240	280	320	360
	Liters	55	73	91	109	127	145	164
<b>1400</b>	Gallons	110	147	183	220	257	293	330
	Liters	51	67	83	100	117	133	150
<b>1600</b>	Gallons	100	133	167	200	233	267	300
	Liters	46	61	76	91	106	121	136
<b>1800</b>	Gallons	90	120	150	180	210	240	270
	Liters	41	55	68	82	95	109	123
<b>2000</b>	Gallons	80	107	133	160	187	213	240
	Liters	36	48	61	73	85	97	109
<b>2200</b>	Gallons	70	93	117	140	163	187	210
	Liters	32	42	53	64	74	85	95
<b>2400</b>	Gallons	60	80	100	120	140	160	180
	Liters	27	36	45	55	64	73	82
<b>2600</b>	Gallons	50	67	83	100	117	133	150
	Liters	23	30	38	45	53	61	68
<b>2800</b>	Gallons	40	53	67	80	93	107	120
	Liters	18	24	30	36	42	48	55
<b>3000</b>	Gallons	30	40	50	60	70	80	90
	Liters	14	18	23	27	32	36	41
<b>3200</b>	Gallons	20	27	33	40	47	53	60
	Liters	9	12	15	18	21	24	27
<b>3400</b>	Gallons	10	13	17	20	23	27	30
	Liters	4	6	8	9	11	12	14
<b>3600+</b>		Ideal	Ideal	Ideal	Ideal	Ideal	Ideal	Ideal
<b>3800</b>		OK	OK	OK	OK	OK	OK	OK
<b>4000</b>		OK	OK	OK	OK	OK	OK	OK
<b>4200</b>		High	High	High	High	High	High	High
<b>4400</b>		Dilute	Dilute	Dilute	Dilute	Dilute	Dilute	Dilute

### **STABILIZER (CYANURIC ACID)**

Always test for stabilizer (cyanuric acid) level, when testing for salt. This test should be done at least once per month. Use the chart below to determine how much stabilizer must be added to raise the level to 80 ppm.

#### **Pounds and (Kg) of Stabilizer (Cyanuric Acid) Needed For 80 PPM**

Gallons and Liters of Pool/Spa Water

Current Stabilizer Level ppm)	Gallons Liters	6,000	8,000	10,000	12,000	14,000	16,000	18,000
		22,500	30,000	37,500	45,000	52,500	60,000	67,500
0 ppm	Gallons	4.0	5.3	6.7	8.0	9.4	10.7	12.0
	Liters	1.8	2.4	3.0	3.6	4.3	4.9	5.4
10 ppm	Gallons	3.5	4.7	5.8	7.0	8.2	9.4	10.5
	Liters	1.6	2.1	2.6	3.2	3.7	4.3	4.8
20 ppm	Gallons	3.0	4.0	5.0	6.0	7.0	8.0	9.0
	Liters	1.4	1.8	2.3	2.7	3.2	3.6	2.2
30 ppm	Gallons	2.5	3.3	4.2	5.0	5.9	6.7	7.5
	Liters	1.1	1.5	1.9	2.3	2.7	3	3.4
40 ppm	Gallons	2.0	2.7	3.3	4.0	4.7	5.4	6.0
	Liters	0.9	1.2	1.5	1.8	2.1	2.4	2.7
50 ppm	Gallons	1.5	2.0	2.5	3.0	3.5	4.0	4.5
	Liters	0.7	0.9	1.1	1.4	1.6	1.8	2
60 ppm	Gallons	1.0	1.3	1.7	2.0	2.4	2.7	3.0
	Liters	0.5	0.6	0.8	0.91	1.1	1.2	1.4
70 ppm	Gallons	0.5	0.7	0.8	1.0	1.2	1.4	1.5
	Liters	0.2	0.3	0.4	0.45	0.54	0.64	0.68

### **POLYMERS:**

It is advised to use polymers (commonly sold as poly algaecide) on saltwater sanitizing systems. The poly algaecide is sold in 30% and 60% concentrations.

Application rate is 1 quart of Poly30 (or Y, quart of Poly 60) per 15,000 gallons (60,000 liters) of pool water, per month. Apply directly in front of the return jet.

## **CONTROLS**

### **MAIN SWITCH**

- **AUTO:** For normal operation, the Main switch should be left in the AUTO position. In this position the CMARSHA will produce chlorine according to the "Desired Level %" adjustment setting for the entire filtering / pumping cycle.
- **SUPER CHLORINATE:** When you have an abnormally high bather load, heavy rainfall, cloudy water conditions, or any other condition which requires that a large amount of purification be introduced, set the Main Switch in the SUPER CHLORINATE position. This electronically "super chlorinates" (shocks) the water for 24 hours (filter pump must be on during this time) or until the power has been turned off, whichever comes first. At the end of the super chlorination period, be sure to put the switch back into the AUTO position.



- **OFF:** The OFF position prevents the CMARSHA from energizing the electrolytic cell. In this position there is no chlorine generation.

**NOTE:** In times of servicing, the OFF switch is not to be used. To service the SPS, turn power off the circuit breaker.

#### **DESIRED LEVEL ADJUSTMENT KNOB**

This setting is used to control the amount of chlorine the CMARSHA generates. Adjust this setting to increase or decrease the chlorine output level. The reading is from 5 percent output to 100% output capacity of the SPS.

#### **INDICATOR LED**

- **POWER:** When illuminated, the CMARSHA has input power.
- **GENERATING:** This LED is on steady during normal operation. When flashing, the pool water is too hot or cold to operate.
- **SUPER CHLORINATE:** Illuminates during Super Chlorination. See description above.
- **REMOTE CONTROLLED:** The part is controlled by a remote-control system.
- **NO FLOW:** When illuminated, the flow switch has detected no flow and CMARSHA is NOT generating chlorine. A flashing LED indicates that the flow is restored, but there will be a 60 second delay before generation is reestablished.
- **CHECK SALT:** When flashing, the salt level is low (below 2500ppm) and CMARSHA is generating at low efficiency. When illuminated steady, the salt level is too low and CMARSHA has shut down.

**Note:** Before adding large quantities of salt, it is advisable to have your salt level professionally checked.

- **HIGH SALT:** When illuminated, the salt level is too high and CMARSHA has shut down. The pool water must be diluted with fresh water before operation is restored.
- **INSPECT CELL:** If flashing, either the cell efficiency is reduced, or it is time for regularly scheduled cell inspection. In either case, inspect the cell and clean if necessary. Pressing the "diagnostic" button next to the display for 3 seconds will stop the flashing LED. When illuminated steady, cell efficiency is greatly reduced and CMARSHA has stopped producing chlorine. Inspect, clean or replace if necessary.

#### **SALT DISPLAY**

The Salt Display shows the current salt concentration of the pool water. Readings are in ppm (parts per million). If Metric units (grams per liter) are preferred, push the "diagnostic" button next to the display once. The display will now show the pool water temperature in degrees Fahrenheit. With the temperature displayed, move the main switch from AUTO to SUPER CHLORINATE to AUTO. **The temperature display will instantly change to degrees Celsius. Repeat this process to switch back to USA units (Fahrenheit).**

#### **DIAGNOSTIC DISPLAYS**

Sequential pushes of the small "diagnostic" button next to the LCD display will cause the Aqua Rite to display the following information:

1. Pool temperature (xx degrees Fahrenheit or Celsius)
2. Cell voltage (typically **21.0 to 27.0 volts** when chlorine is being generated, **otherwise I6-25V**)
3. Cell current (typically **2.50 to 7.80 amps** when chlorine is being generated, otherwise 0 amps)
4. Desired Output % ("OP" -- "I OOP" depending on knob position or input from remote pool automation controller)

5. Instant salinity ( -xxxx ppm or -x.xx grams/Liter)
6. Product name sent to the pool automation control display
7. Software revision level
8. Cell type

On the 8th push of the button the display will revert back to the default salt display. Also, if the button is not pushed for 30 seconds, the display will revert back too.

### **OPERATION**

By familiarizing yourself with the operation of the CMARSHA generator, you can achieve maximum performance for your pool. When chemical levels are in the recommended range, there are FOUR factors that you can control which directly contribute to the amount of chlorine the CMARSHA will generate:

- Filter time each day (hours)
- The amount of salt in the pool
- The "Desired Level %" setting
- Stabilizer level in the water.

To find the optimum "Desired Level %" setting, start at a fairly high setting and work downward. It will take a few days of adjustments to find the ideal setting for your pool. Once determined, it should only take minor adjustments. The CMARSHA control will not produce chlorine at temperatures below 50°F. If the pool water is colder than 50°F, you must chlorinate manually.

## MAINTENANCE

### **Maintaining the System**

To maintain maximum performance, it is recommended that you remove and visually inspect the cell every 3 months. The CMARSHA will remind you to do this by flashing the "Inspect Cell" LED after approximately 500 hours of operation. After you inspect the cell (and clean, if necessary) press the small "diagnostic" button next to the display for 3 seconds to stop the flashing "Inspect Cell" LED and start the timer for the next 500-hour inspection period.

The CMARSHA electrolytic cell has a self-cleaning feature incorporated into the electronic control's logic. In most cases this self-cleaning action will keep the cell working at optimum efficiency. In areas where water is hard (high calcium and/or mineral content) and in pools where the water chemistry has gotten "out of balance", the cell may require periodic cleaning. The "Inspect Cell" LED remains on after a thorough cleaning, the cell may be worn and may require replacement.

### **Servicing and Cleaning the Cell**

- Turn off power to the CMARSHA before removing the CELL.
- Once removed, look inside the cell and inspect for scale formation (light colored crusty or flaky deposits) on the plates and for any debris that has passed through the filter and gotten caught on the plates.
- If no deposits are visible, reinstall. If deposits are seen, use a high-pressure garden hose and try to flush the scale off. If this is not successful, use a plastic or wood tool to scrape deposits off of the plates. DO NOT USE A METAL SCRAPER AS THIS WILL SCRATCH THE FINISH AND DAMAGE THE PLATES. Note that a buildup on the cell indicates

that there is an unusually high calcium level in the pool (old pool water is usually the cause). If this is not corrected, you will need to clean the cell more frequently. The simplest way to avoid this is to bring the pool chemistry to recommended levels, as specified.

### **Mild Acid Washing**

Use only in severe cases where flushing and scraping will not remove the majority of deposits. To acid wash:

- Turn off power to SPS.
- Remove cell from piping.
- In a clean plastic container, carefully mix a 4: 1 solution of water to muriatic acid (one gallon of water to one quart of muriatic acid).

**ALWAYS POUR ACID INTO WATER-NEVER POUR WATER INTO ACID. BE SURE TO WEAR PROTECTIVE GLASSES, CLOTHING AND CHEMICAL RESISTANT GLOVES.**

- The level of the solution in the container should just reach the top of the cell so that the wire harness compartment is NOT submerged. It may be helpful to coil the wiring before immersing the cell.
- The cell should soak for FIVE minutes, then rinse with a high-pressure garden hose.
- If any deposits are still visible, repeat soaking and rinsing.
- Replace cell and inspect again periodically.

### **Winterizing**

The CMARSHA electrolytic cell and flow detection switch will be damaged by freezing water, similar to other pool components that require proper winterization. In areas of the country that experience severe or extended periods of freezing temperatures, be sure to drain all water from the pump, filter, and supply and return lines before any freezing conditions occur. The electronic control is capable of withstanding any winter weather and should not be removed.

### **Spring Start-up**

DO NOT turn CMARSHA on, until the pool water chemistry has been balanced to proper levels.

## **INSTALLATION**

*Installation must be performed in accordance with Local NEC codes.*

### **Preparing Pool Water**

The pool's chemistry must be balanced BEFORE activating the SPS. It is recommended that you consult a pool professional for the initial balancing each season.

NOTE: At the beginning of each season, add metal remover and polymer based (non copper) algaecide to the pool, per manufacturer's instructions. This ensures a quick, trouble free transfer to the CMARSHA system.

## MOUNTING

The CMARSHA is contained in a rain tight enclosure that is suitable for outdoor mounting. The control must be mounted a minimum of 5 ft. (2 meters) horizontal distance (or more if local codes require) from the pool/spa.

The control is designed to mount vertically on a flat surface with the knockouts facing downward. Because the enclosure also acts as a heat sink (disperses heat from inside the box), it is important not to block the four sides of the control.

Do not mount the CMARSHA in a panel or tightly enclosed space.

## PLUMBING

Ensure that the CMARSHA installation does not constitute a cross connection with the local potable water supply. Consult local plumbing codes.

The cell and flow switch are plumbed in the return line to the pool. Install after (downstream) all the pool equipment (filter, heater, solar, etc.). The kit included in the CMARSHA provides the necessary plumbing components for:

- 2" (51mm) rigid PVC piping installation for in ground pools
- 1-1/2 or 1-1/4" (38-32mm) flexible hose connections for above ground pools For proper plumbing, refer to the overview diagram below

### Flow Switch

**IMPORTANT:** To insure proper operation, verify that the arrow on the flow switch (located **on the side**) points in the same direction of water flow.

### Electrolytic Cell

Install using the unions provided. Tighten by HAND for a watertight seal. For pool/spa combination systems with spillover, use configurations #2 or #3 above to allow chlorination for both the pool and spa during spillover but preventing over chlorination when operating the spa only.

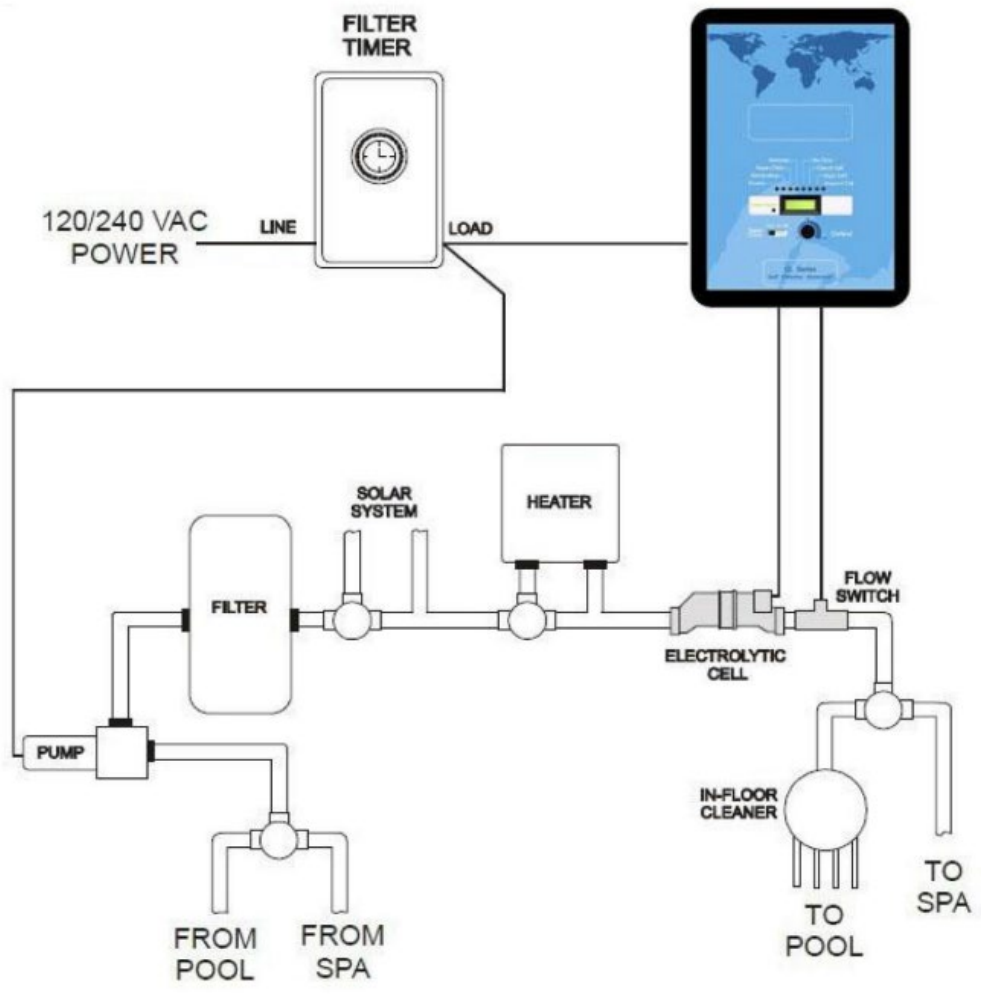

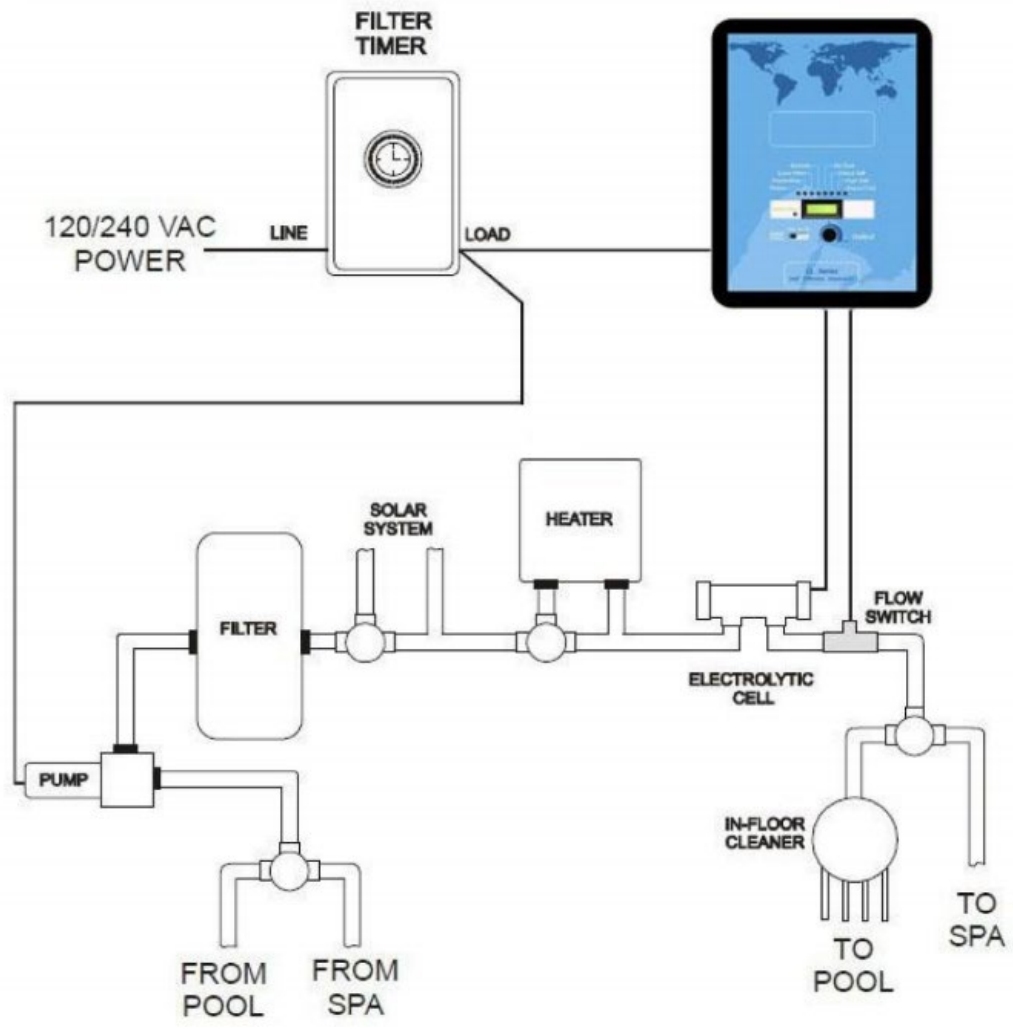

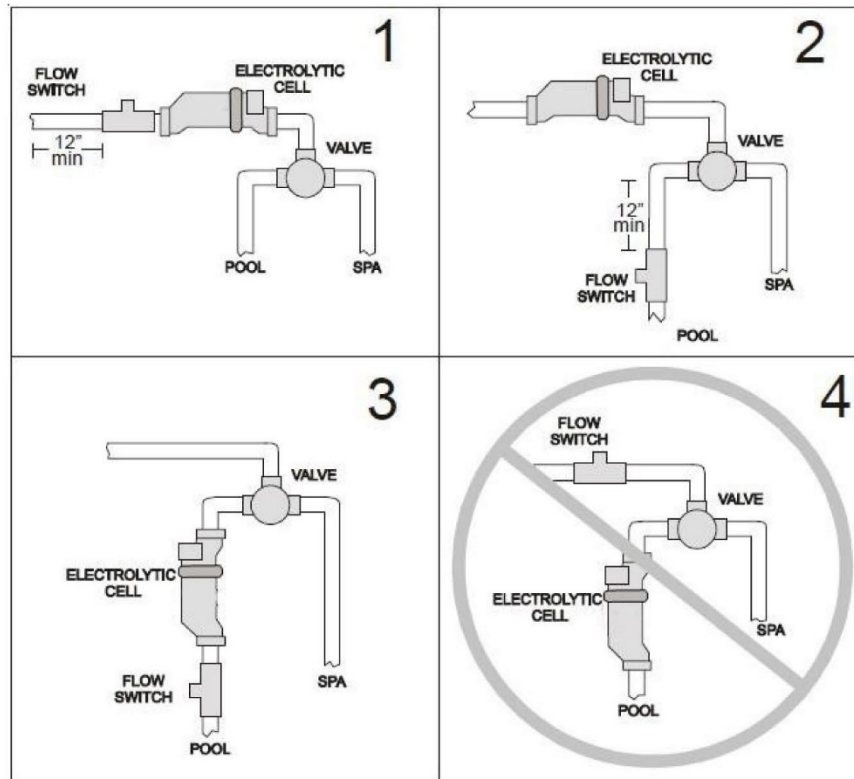

## WIRING

Power must be turned off at the circuit breaker before performing any wiring. Be sure to follow Local and NEC electrical codes. To provide safe operation, CMARSHA must be properly grounded and bonded.

### **INPUT POWER FOR STAND-ALONE OPERATION**

Wire the CMARSHA to the LOAD SIDE of the filter pump timer. It is very important that the CMARSHA is powered only when the pump is running.

Refer to the wiring label on CMARSHA as well as the diagram below to determine correct wiring connections. The CMARSHA is shipped from the factory with the configuration jumpers in a separate bag. Until the jumpers are installed for the desired voltage, the unit should NOT be turned on.

- For Canadian models, the CMARSHA shall be connected to a circuit protected by a class A ground fault interrupter. Be sure to connect the GROUND wire to the green ground screw terminal located on the INSIDE WALL of the enclosure.

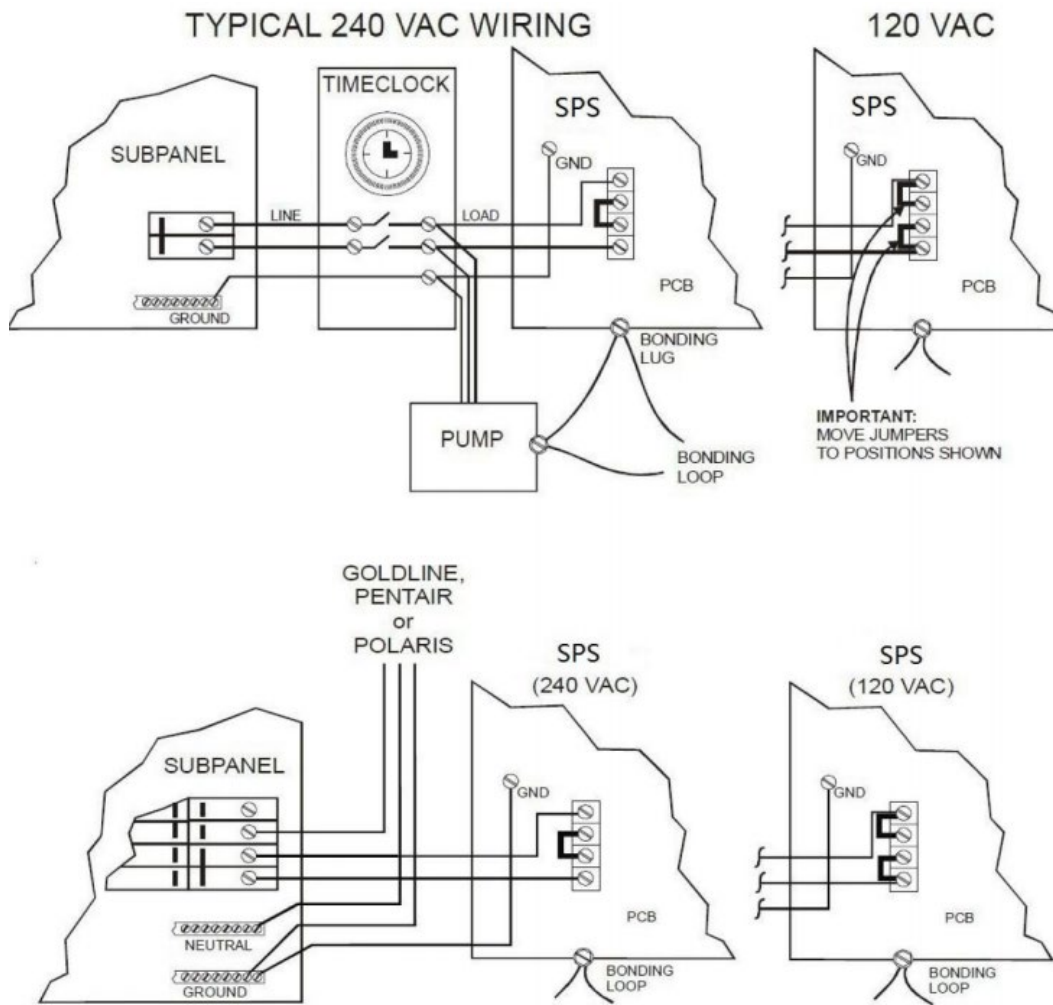

**Note:** Wire the pump directly to the time clock-do not use the CMARSHA as a junction box.

***BONDING***

A lug used for bonding is attached to the bottom of the CMARSHA enclosure (see diagram below). The CMARSHA must be bonded with an 8 AWG copper wire (6 AWG Canada) to the pool bonding system.

**Electrolytic Cell and Flow Switch**

The electrolytic cell and flow switch cables are terminated with connectors that plug into the CMARSHA for easy attachment and removal. The door of the CMARSHA must be open to access the cell cable connector. The flow switch plugs into a connector (similar to a telephone jack) located outside on the bottom of the enclosure. Refer to the diagram below for the location of these connections.



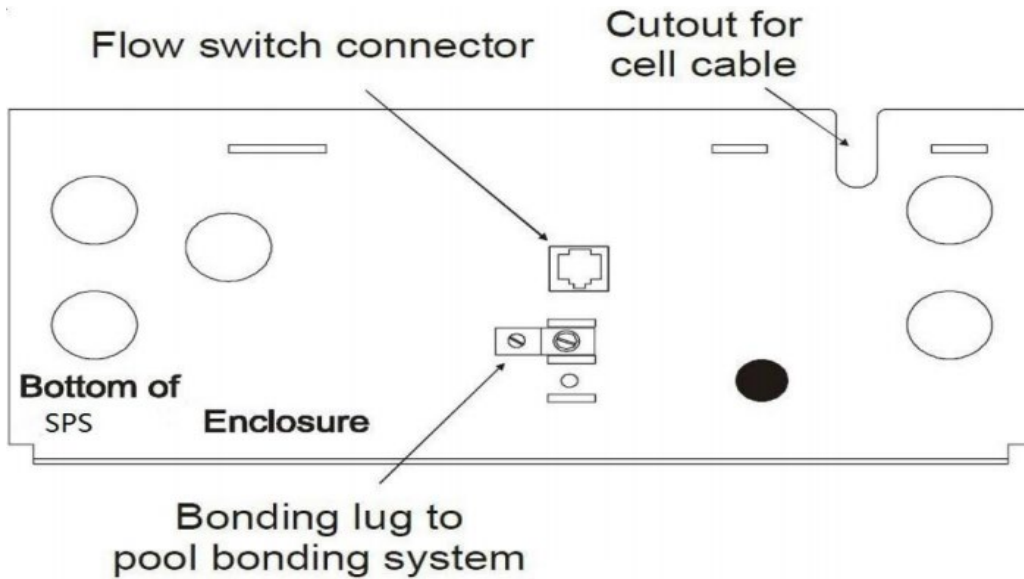

**Input Power for use with Goldline, Pentair and Polaris Controls**

Wire the CMARSHA DIRECTLY TO 120/240vac POWER (not through timer or relay). Optional Goldline, Pentair and Polaris controls:

The Goldline, Pentair and Polaris controls use a 4-wire connection to communicate to the CMARSHA and can be wire up to 500' apart. Any outdoor rated 4 conductor cable can be used. Refer to each manufacturer's instructions and the wiring diagrams below for proper wiring connection to the SPS.

**NOTE:** There must be only 1 "primary" unit. All other CMARSHA units must be configured as "secondary".

**Goldline** - Attach wires to proper screw terminals as show below.

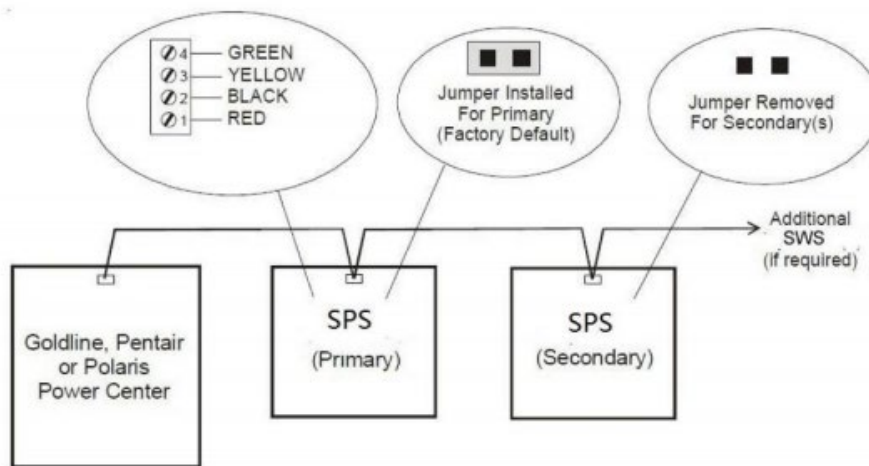

**Goldline** - Attach wires to proper screw terminals as shown below.

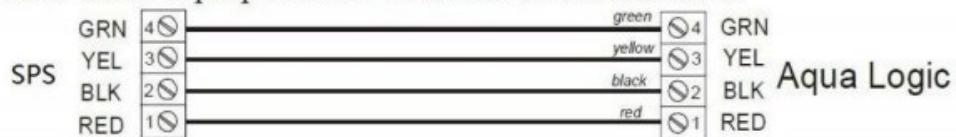

**Pentair** - Attach wires to opposite numbered screw terminals as shown below. Note that the colors marked on the Pentair PCB do not match the SPS.

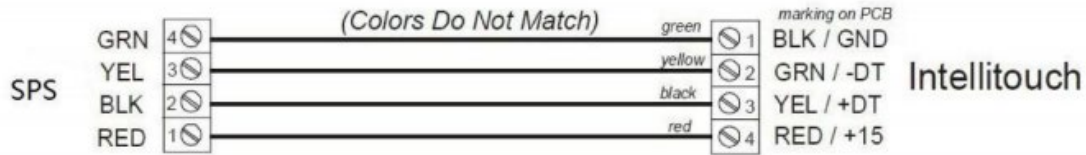

**Polaris** - Attach wires to proper screw terminals as shown below. Note that screw terminal "1" is marked on the Polaris PCB.

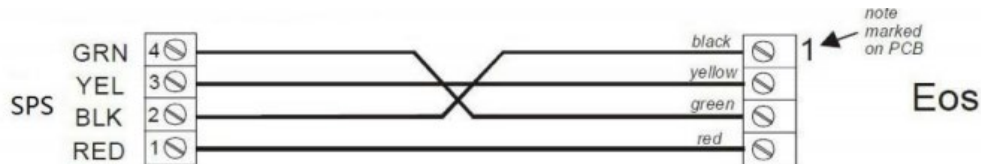

## TROUBLESHOOTING

### DIAGNOSTIC DISPLAYS

Sequential pushes of the small "diagnostic" button next to the LCD display will cause the CMARSHA to display the following information:

1. Pool temperature (xx degrees Fahrenheit or Celsius)
2. Cell voltage (typically 21.0 to 27.0 volts when chlorine is being generated, otherwise 16-25V )
3. Cell current (typically 2.50 to 7.80 amps when chlorine is being generated, otherwise 0 amps)
4. Desired Output% ("OP"- "100P" depending on knob position)
5. Instant salinity (-xxxx ppm or -x.xx grams/Liter)
6. Product name sent to the display
7. Software revision level
7. Cell type

On the 8th push of the button the display will revert back to the default salt display. Also if the button is not pushed for 30 seconds, the display will revert back default salt.

### COMMON PROBLEMS AND SOLUTIONS

1. "Power" LED not on
  - Check to make sure 120 / 240 VAC input power is connected to the control. Be sure the jumpers are set properly. Verify input voltage with a voltmeter. If there is input power, the fuse may have blown. The board is protected by a 20 amp mini ATO fuse located on the circuit board above the cell connector.
2. "Generating" LED flashing
  - The temperature of the pool water is too high or low to operate. You can override this by switching the main switch to SUPER CHLORINATE. The CMARSHA will run at maximum output for the remainder of the current pump cycle or 24 hours, whichever comes first.
3. "No Flow" LED illuminated or flashing

- The CMARSHA has sensed a no flow condition and has stopped generating chlorine. Check that the flow switch is plugged into the connector on the bottom of the control unit and that the wire is not cut or damaged. Make sure you have at least 12" of straight pipe before the flow switch. If there is adequate flow and the LED is still on, check that the arrows on the flow switch (on top of hex) are pointing in the direction of flow. If the light is flashing, the flow is established and the CMARSHA will turn on within 1 minute.
4. "Check Salt" LED illuminated or flashing
    - Check salt level in pool/spa. If salt level is low, add salt according to chart on page 4. Before adding large quantities of salt, it is advisable to have your salt level professionally checked.
  5. "High Salt" LED illuminated
    - Check salt level in pool/spa. If salt level is too high, lower salt level by draining some of the pool water out of the pool and replace with fresh water. Continue until the salt concentration is at recommended levels.
  6. "Inspect Cell" LED flashing
    - Inspect and clean cell according to directions. When done, press the "diagnostic" button for 3 seconds to stop the "Inspect Cell" LED flashing.
  7. "Inspect Cell" LED illuminated
    - Remove and inspect the cell for scale. If the cell is scaled, follow the directions on page 8 for cell cleaning. If the pool has the proper amount of salt and the "Inspect Cell" LED is still illuminated, the cell may be depleted and needs to be replaced.
  8. Possible causes of low chlorine or no chlorine
    - CMARSHA switch in OFF position.
    - Desired Level% adjustment setting is too low.
    - Low stabilizer (Cyanuric Acid) .Chlorine is being produced but the pool water is unable to hold on to the chlorine, due to low stabilizer.
    - Filter pump switched off or filter pump time too short (8 hours for average size pools, more for large pools).
    - Salt level too low (below 2500 ppm, Low Salt LED on).
    - Salt level too high (high Salt LED on).
    - Low pH. Low pH oxidizes chlorine quickly, making it difficult to maintain desired chlorine levels. Adjust pH levels to re-balance water.
    - Warm pool water increases chlorine demand-increase Desired Level% or filter run time.
    - Cold water (below 50F) can cause CMARSHA to stop generating (Generating LED flashing).
    - Excessive scaling on cell.
    - High level of phosphates in pool water.
    - Some yellow algae treatments will use chlorine at a very high rate and deplete the residual free chlorine. Manually shock the pool if indicated in the directions on the algae treatment. It still may be a matter of days before the pool returns to "normal" and chlorine tests will show the desired 1-3ppm free chlorine reading.
  9. "PCB" displayed and all 4 LEDs are illuminated.
    - A possible printed circuit board fault has been detected. Call for service.

## WARRANTY

### **THREE (3) YEAR LIMITED WARRANTY**

The CMARSHA Salt Chlorination System is warranted to be free from defects in materials and workmanship, under normal use and non-commercial application, for a period of Three (3) years, per the schedule below. To obtain service, contact the authorized dealer from which the unit was purchased. Proof of purchase may be required. This limited warranty is extended exclusively to the original purchaser of the CMARSHA system and is non-transferable. CMARSHA is intended for residential pool use and any commercial application voids all warranties.

Three (3) year limited warranty schedule for power center and generating cell.

During year one:	100%
During year two:	70%
During year three:	30%

All remaining components: one year, full

### **Exclusions:**

- Problems arising from failure to maintain proper water chemistry levels, per manufacturer's recommendations, as outlined in the Owner's Manual.
- Problems arising from failure to use CMARSHA in accordance to manufacturer's recommendations, as outlined in the Owner's Manual.
- Problems resulting from tampering, accident, electrical surges, abuse, neglect, unauthorized or unqualified repairs, product alteration, fire, flood, freeze damage, Acts of Nature or Acts of God.
- Damage or degrading of concrete, natural stone, wood or synthetic surfaces adjacent to the swimming pool or spa.
- Problems or damages incurred due to improper installation and/or improper electrical supply.

**Disclaimers:** This limited warranty constitutes the entire warranty. No other warranties apply, expressed or implied. This limited warranty gives you specific legal rights, which vary from state to state. Under no circumstances shall CaliMar® or authorized agent/installer be responsible for consequential, special, or incidental damage(s) of any kind, including but not limited to personal injury, property damage, or damage to or loss of equipment. CaliMar® or agent/installer is not liable for any other expenses that may be incurred during installation or servicing. Authorized agents/installers may charge a trip fee for warrantable service work.

Some states do not allow the exclusion of limitations of incidental or consequential damages. Listed exclusions and limitations may not apply to you.



CaliMar Pool Products USA, Inc.  
Manufacturers of Innovative & Quality Pool & Spa Products  
(888) 635-0330  
sales@calimarpool.com  
www.calimarpool.com