

This box contains the following items:

ITEM #	QTY.	DESCRIPTION	RE-ORDER #
1	12	Self-tapping Screw	501
5	2	5/16"x1" Bolt	505
11	2	3/8"x6" Anchor Bolt	511
15	2	Concrete Anchor	515
19	2	5/16" Washer	505
21	8	3/8" Washer	21
25	2	Spring	517
29	4	Acorn Nut	523
55	2	#3 A-Frame	55
61	1	White Knob	533
65	2	4" Regular Hub	539
71	1	Small Handle	545
101	10	Male Grommet	549
103	10	Female Grommet	549
105	2	Plastic Bushing	555
107	2	Plastic Washer	555
109	2	Spring Guard	109
201	1	22' Strapping	587
209	4	2" Plastic Wheels	583

Any questions, check out our Web Site:
www.rockysrollers.com
 Go to **FAQ** (Frequently Asked Questions)

Tools Required:

Reversible Electric Drill
1/2" Concrete (masonry) Drill Bit
Hammer & Center Punch or Nail.
5/16" Hex Head Socket Bit
1/2" Wrench
5/8" Wrench

ROCKY'S EAZY ROLLERS® INSTRUCTIONS - #3 PORTABLE

1 For use with 4" (outside diameter) aluminum irrigation tubing. *(Not Supplied By Rocky's)*

NOTE:
 Tube length should be about 1' wider than pool. Insert one end of irrigation tubing into 4" hub (item #65).

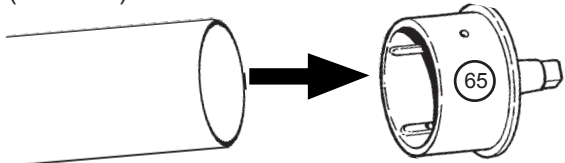

With 2 self-drill/tapping screws (item #1), attach hub to tube using electric drill. Apply pressure to ensure screw cuts into aluminum tube then cuts it's own thread. *(No predrilling required)* **Repeat with other side.**

SELF-DRILLING

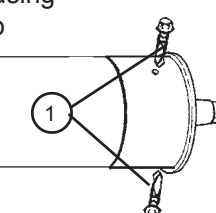

2

NOTE:
 APPLY WATERPROOF GREASE.

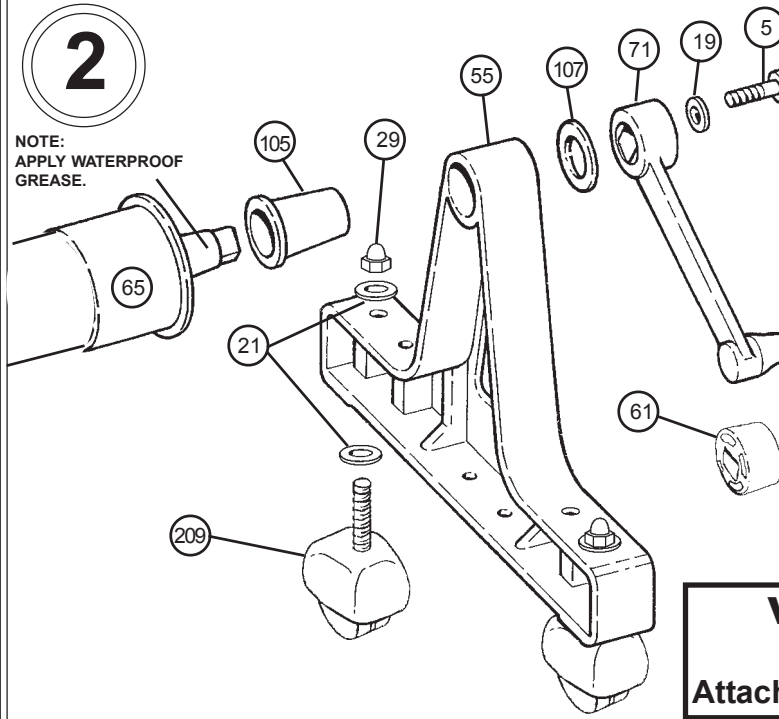

Bolt the castors (item #209) to the A-frames (item #55), as shown in the diagram.

Assemble one end unit to the tube, using the small handle (item #71), as shown in the diagram.

Assemble the other end unit to the tube, using the white knob (item #61). For smoother operation, apply petroleum based grease between the hub (item #65) and the black bushing (item #105). This should be done once a year.

Position the assembled roller unit at the widest end of the pool.

VERY IMPORTANT
PREVENT DROWNING
Attach Warning Label to one end of tube.

3

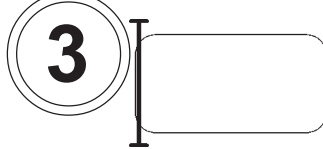

For regular shaped pools, align the outside edge of the tube parallel with the end of the pool.

For irregular shaped pools, the outside edge of the tube should be 3' inside from the end of the pool.

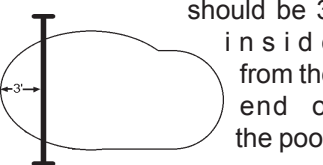

4

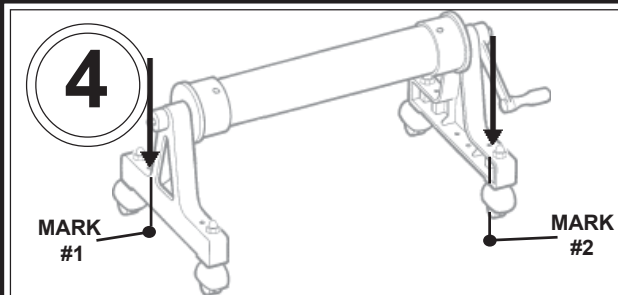

Using one of the two holes in the A-frame as a guide, make mark #1 on deck. With a 1/2" concrete drill bit, drill a 1 1/2" deep hole at mark #1. Complete steps 5 and 6 before continuing with step 4. On the other side of the roller unit, make mark #2 by using one of the two holes in the A-frame as of guide. With a 1/2" concrete drill bit, drill a 1 1/2" deep hole at mark #2.

NOTE:
Set one bolt at front of frame on one end and one at the rear of the frame on the other end.

5

Drive the concrete anchor into the hole with a hammer. Leave the anchor raised 1/16".

To set the concrete anchor, then tap the slug into the hole with a hammer, then using a center punch or large nail drive the slug down into the anchor forcing legs out into concrete.

Hit center slug with hammer & center punch, or large nail.

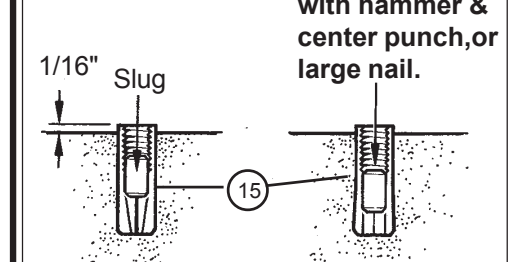

6

Insert the anchor bolt (item #11) through the spring (item #25), through the spring guard (item #109) and through the hole of the A-frame.

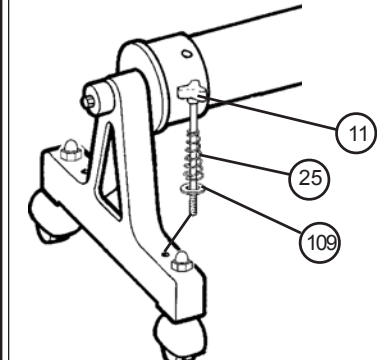

FOR REGULAR SHAPED INGROUND POOLS

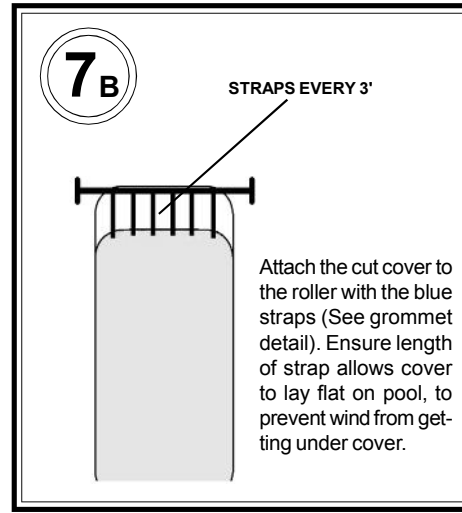
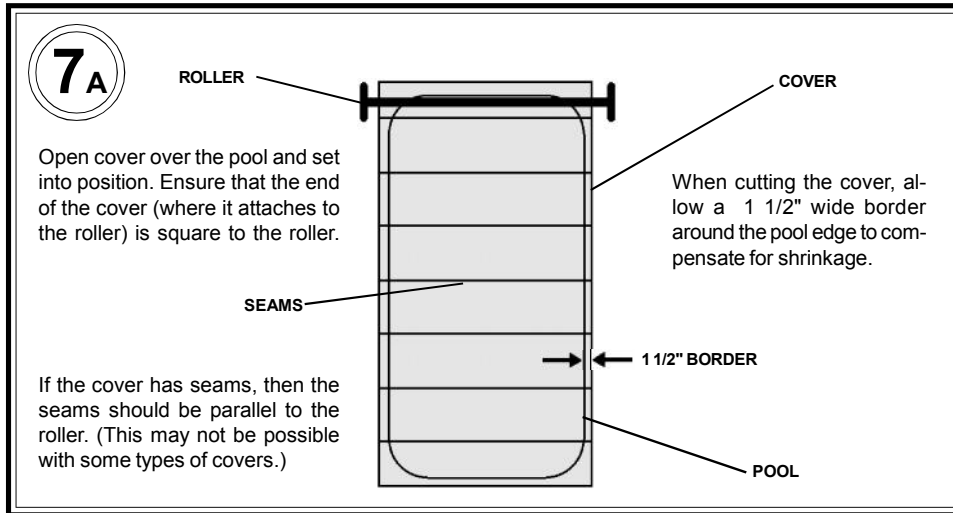

GROMMET DETAIL

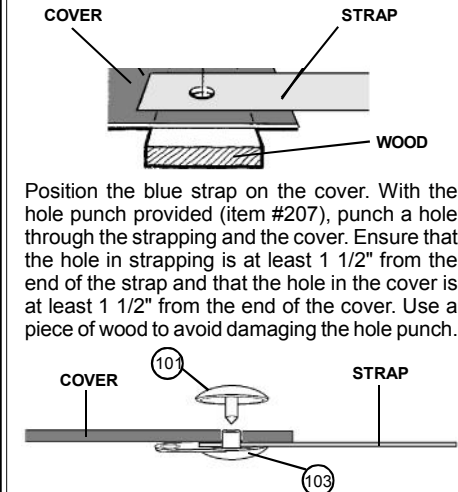

Insert female grommet (item #103) through hole in strapping and cover. Ensure that material is completely pushed down shaft. Insert male grommet (item #101) into female grommet. Once in place, hit gently with hammer until secure. (Caution - excess force will break grommet).

For odd shaped pools, pinch the cover and attach the strap as shown.

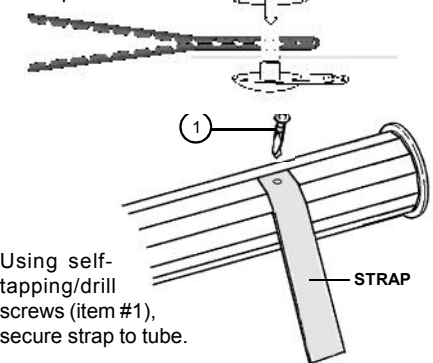

FOR IRREGULAR, KIDNEY, OR ROUND SHAPED INGROUND POOLS

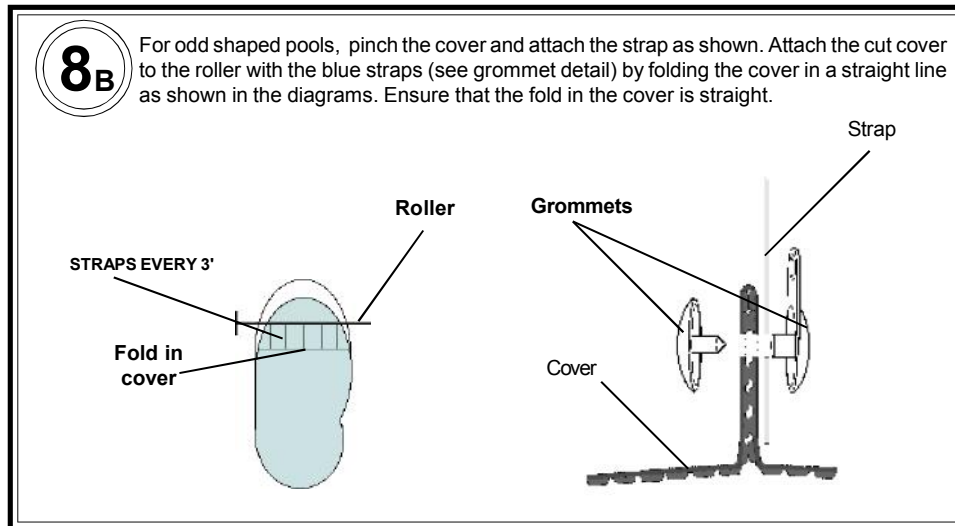
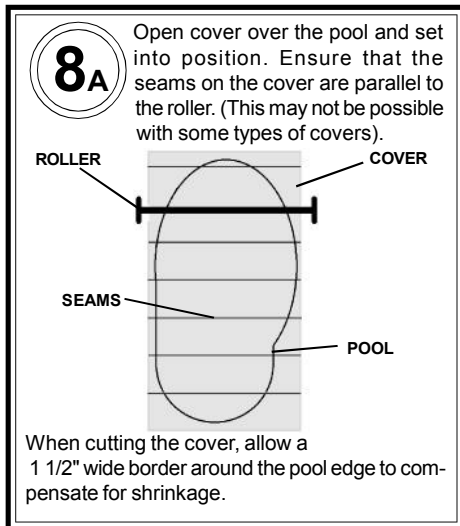

ROCKY'S REEL SYSTEMS INC.

Tel: (604) 985-0525

Fax: (604) 985-4325

North America: Tel: 1-800-663-8705 Fax: 1-800-811-9966 Web Site: www.rockysrollers.com E-Mail: info@rockysrollers.com