

# SPA SERIES WOOD DECK ANCHOR

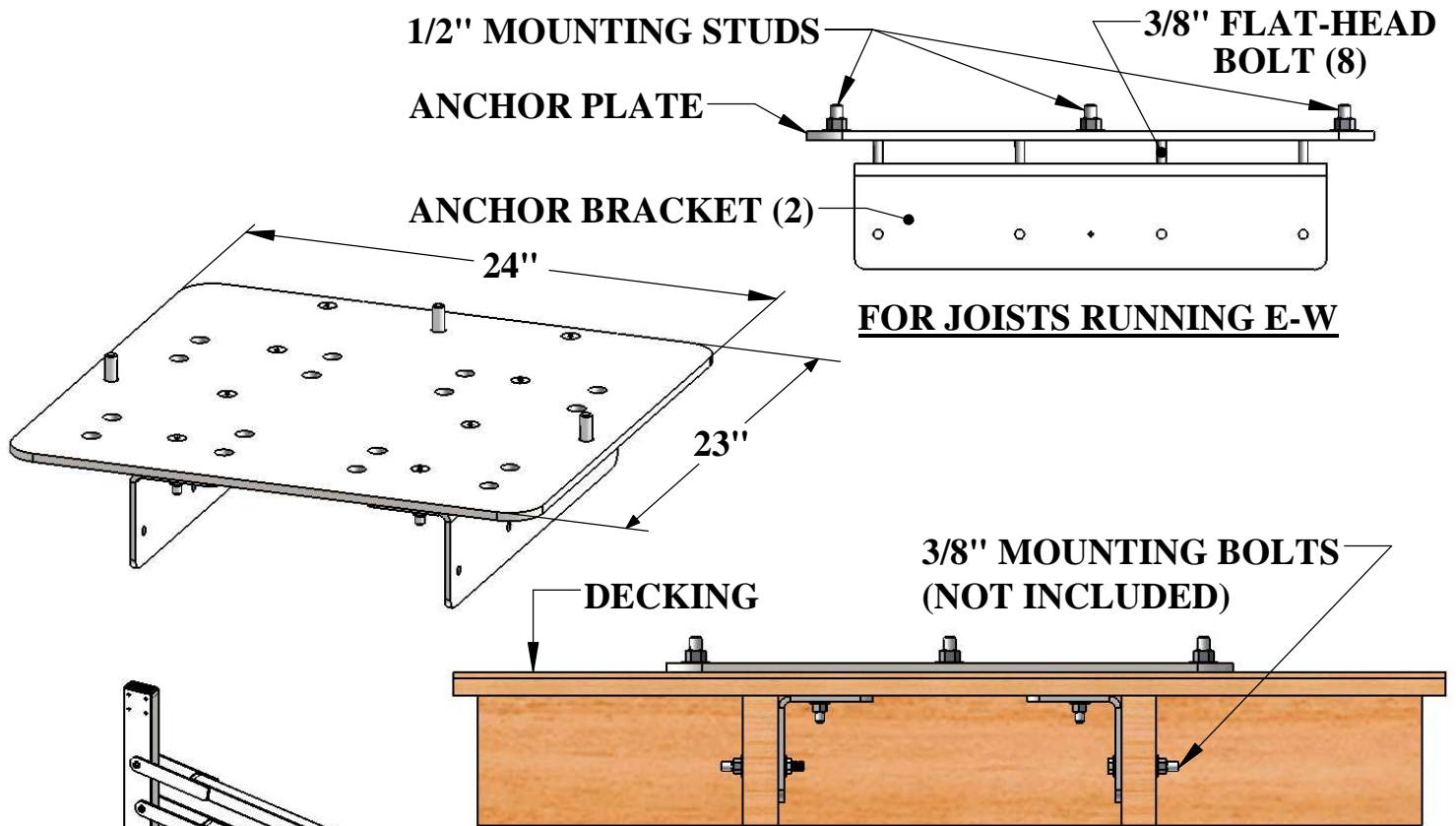

**FOR JOISTS RUNNING E-W**

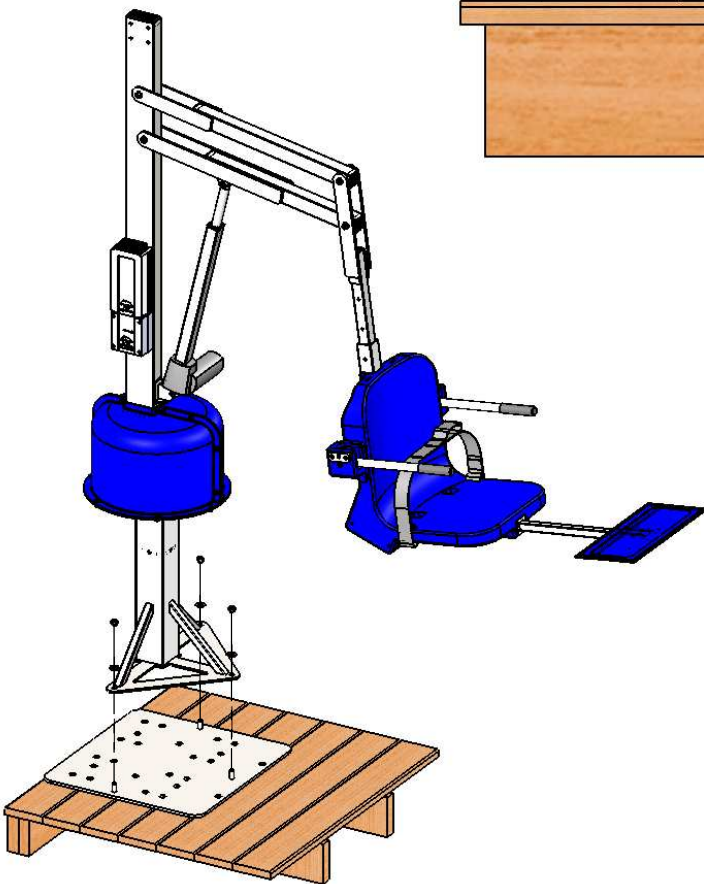

**FOR JOISTS RUNNING N-S**

**THE SPA SERIES WOOD DECK ANCHOR HAS BEEN DESIGNED TO BE USED ON WOODEN DECKS WITH JOISTS 16" O.C., WITH THE JOIST ORIENTATION BEING IN EITHER THE "EAST-WEST" OR THE "NORTH-SOUTH" DIRECTION. THE KIT CONSISTS OF A 3/8" THICK BASE PLATE AND TWO (2) 1/4" THICK BRACKETS. THE BRACKETS ARE BOLTED DIRECTLY TO THE DECK JOISTS (2X6 MINIMUM) AND THE ANCHOR PLATE BOLTS THRU THE DECKING TO THE BRACKETS. THE KIT COMES WITH EIGHT (8) FLAT-HEAD BOLTS FOR ATTACHING THE BRACKETS. ALL MATERIALS ARE STAINLESS STEEL, AND POWDER COATED FOR LONG LIFE. THE WOOD DECK ANCHOR IS FOR THE SPA LIFT ELITE AND SPA LIFT ULTRA.**

9889 GARRYMORE LANE  
 MISSOULA, MT 59808  
 (406) 549-0769  
 FAX (406) 549-2602

NOTE:  
 \*SPECIFICATIONS ARE SUBJECT TO CHANGE WITHOUT NOTICE

PRODUCT:	F-107UEWDA	
DWG #:	F-107UEWDA-1	
SCALE:	1:8	DATE: 1/15/16
DRAWN BY:	KR	REVISION: A