

SOLAR BATTERY CHARGER

FOR THE PATRIOT PORTABLE LIFT

SPECIFICATIONS:

OPERATING VOLTAGE (MAX): 35VDC
 OPERATING CURRENT (MAX): 225mA
 HEIGHT: 80" [2032 mm]
 WIDTH: 14" [355.6 mm]
 DEPTH: 14" [355.6 mm]
 WEIGHT: 16 lbs [7.3 kg]
 FRAME MATERIAL: 304 S.S.
 SOLAR PANELS: TWO (2) 12V, 4W
 THIN-FILM FLEXIBLE (CIGS)

CHARGE CONTROLLER:

PROTECTION RATING: IP68
 [CONTROLLER: 1.5 m, 72 HOURS]
 SHORT-CIRCUIT PROTECTED
 REVERSE-POLARITY DETECTION
 OVERCHARGE DETECTION
 (PREVENTS BATTERY DAMAGE)

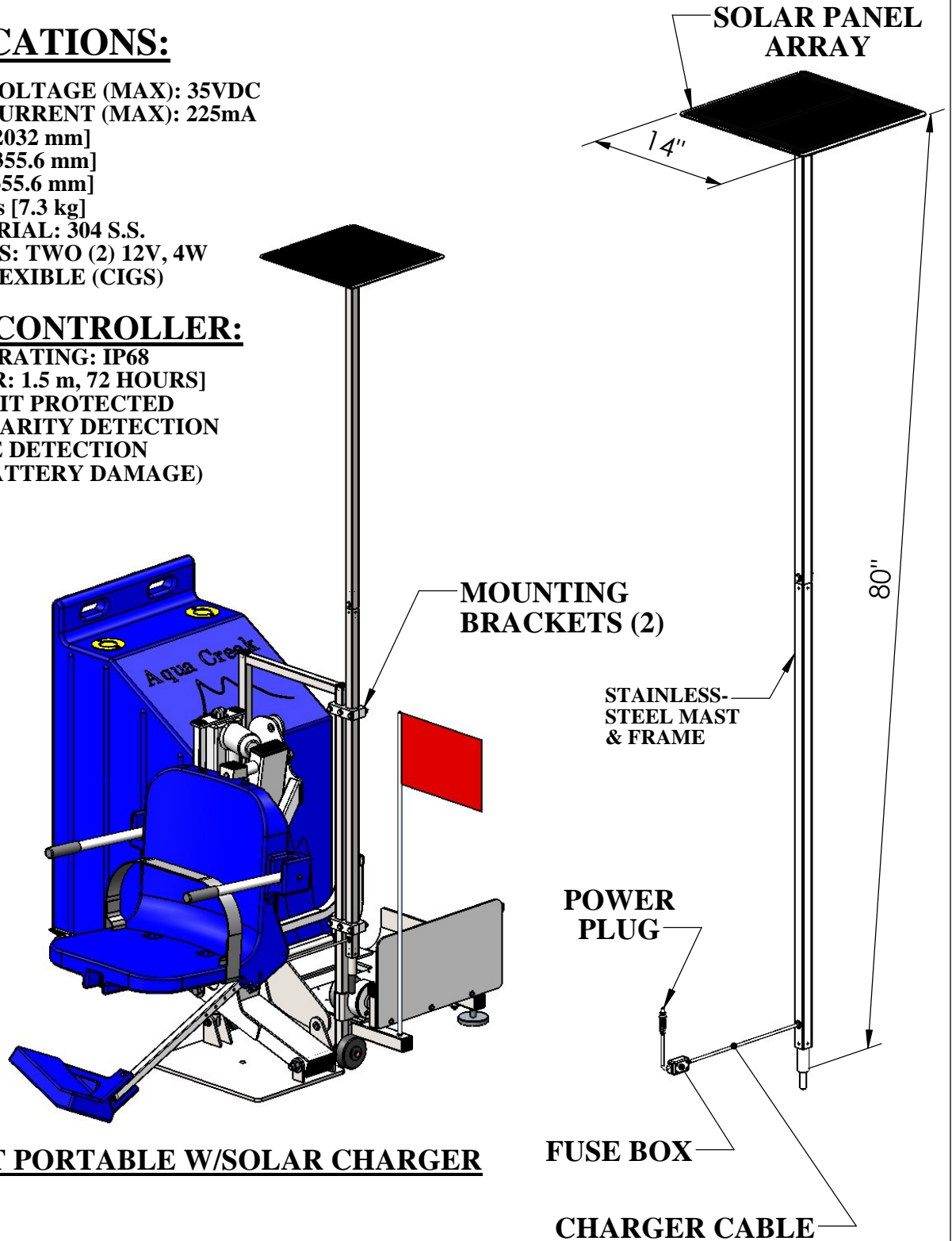

PATRIOT PORTABLE W/SOLAR CHARGER

9889 GARRY MORE LANE
 MISSOULA, MT 59808
 (406) 549-0769
 FAX (406) 549-2602



Aqua Creek Products
 The Total Solution for Pool and Spa Access

NOTE:
 *SPECIFICATIONS ARE SUBJECT TO CHANGE WITHOUT NOTICE
 *ALL DIMENSIONS ARE IN INCHES

PRODUCT:	F-043SCH	
DWG #:	F-043SCH-1	
SCALE:	1:12	DATE: 11/14/14
DRAWN BY:	DS	REVISION: B