

22" UNDER WATER WALKER

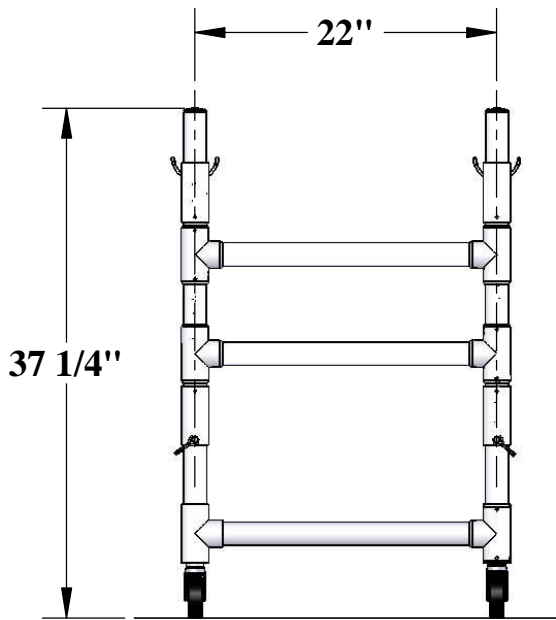

FRONT VIEW

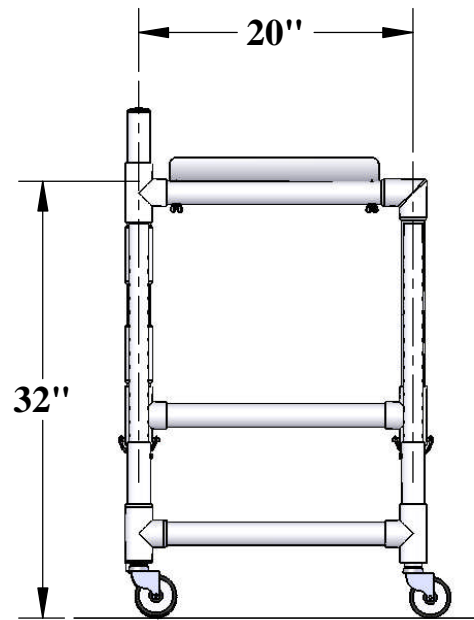

SIDE VIEW

SHOWN AT LOWEST HEIGHT ADJUSTMENT

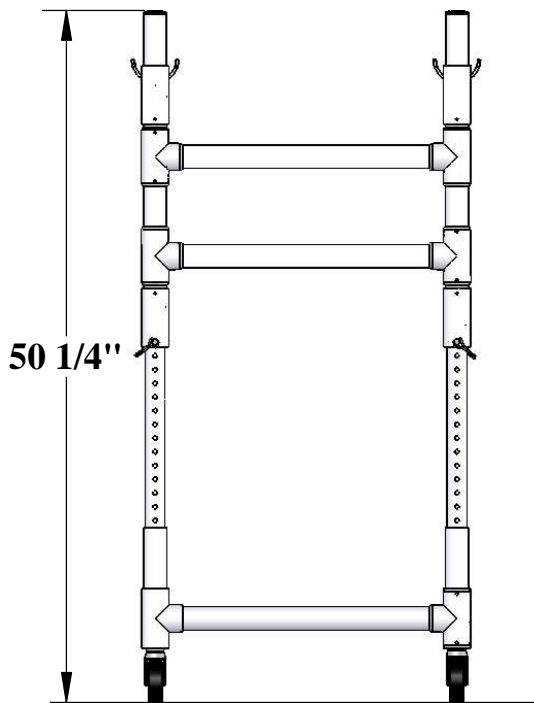

FRONT VIEW

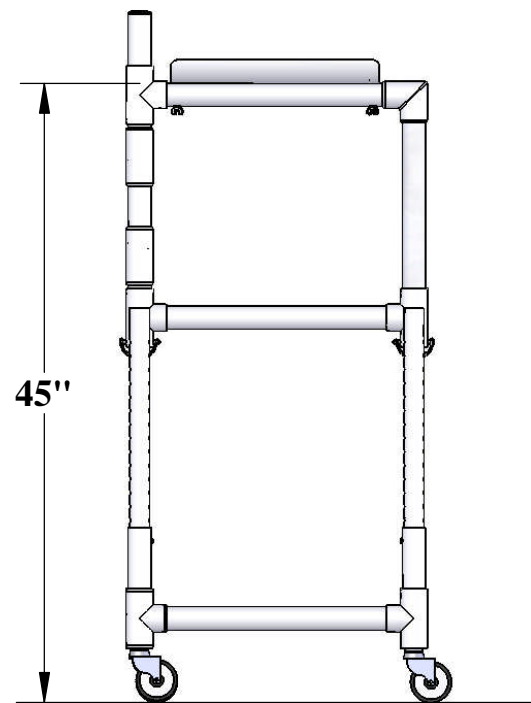

SIDE VIEW

SHOWN AT HIGHEST HEIGHT ADJUSTMENT



9889 GARRYMORE LANE
 MISSOULA, MT 59808
 (406) 549-0769
 FAX (406) 549-2602

NOTE:
 *SPECIFICATIONS ARE SUBJECT TO CHANGE WITHOUT NOTICE

PRODUCT:	F-605UW	
DWG #:	F-605UW-1	
SCALE:	1:10	DATE: 2/5/15
DRAWN BY:	KR	REVISION: C

22" UNDER WATER WALKER

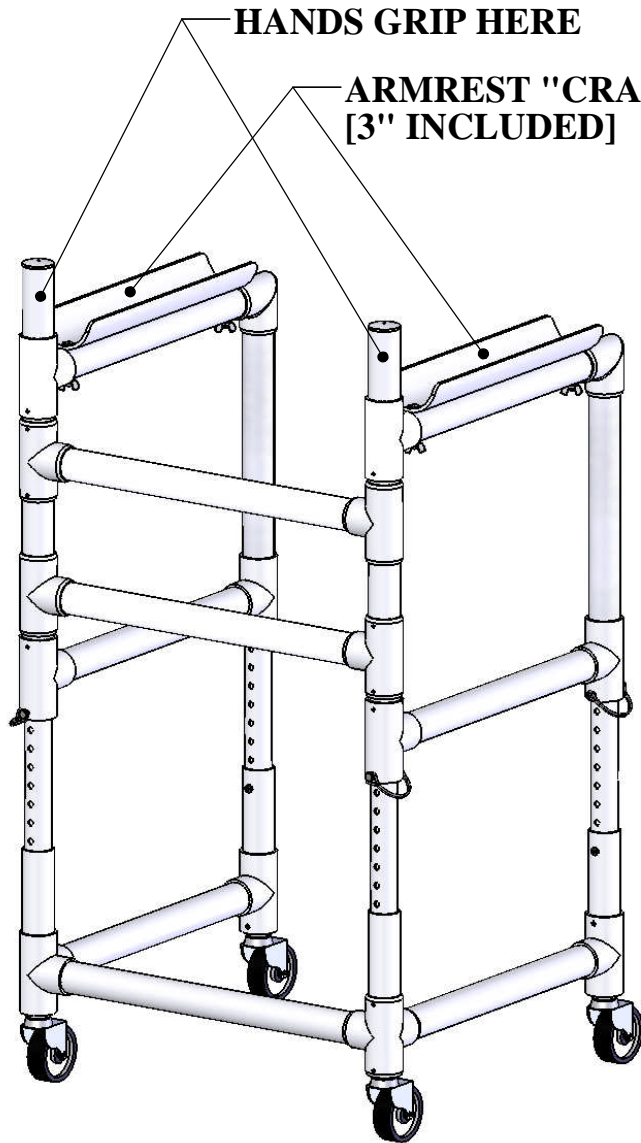

WITH ARMREST OPTION

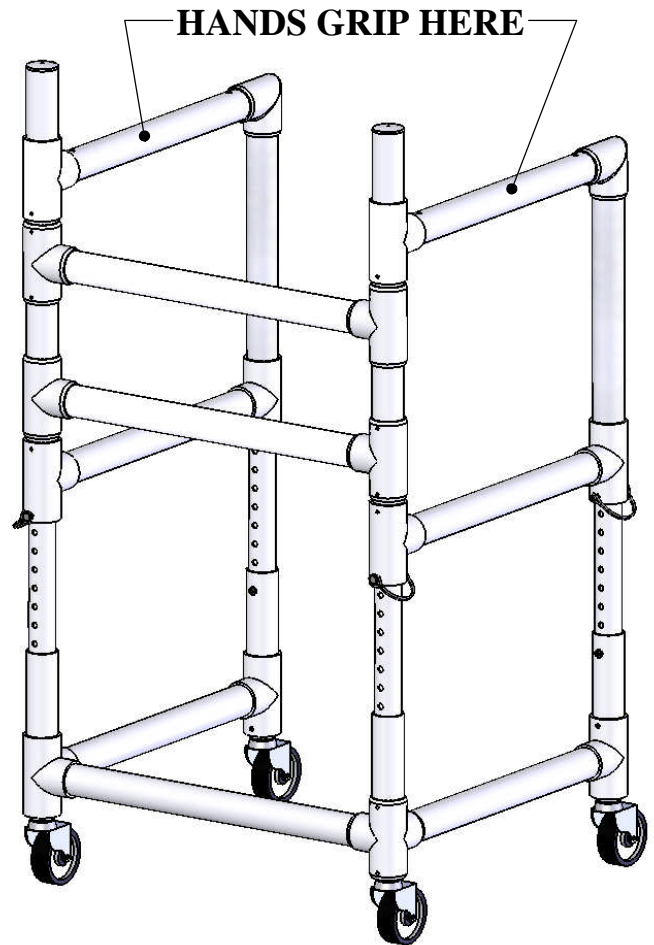

**WITHOUT ARMREST OPTION
(STANDARD WALKER CONFIG.)**

ARMREST "CRADLES" ARE REMOVABLE TO CONVERT TO THE STANDARD WALKER CONFIGURATION. THE WATER-WALKER COMES STANDARD WITH 3" ARMREST CRADLES (4" ARMREST CRADLES ARE AVAILABLE).



9889 GARRYMORE LANE
 MISSOULA, MT 59808
 (406) 549-0769
 FAX (406) 549-2602

NOTE:
 *SPECIFICATIONS ARE SUBJECT TO CHANGE WITHOUT NOTICE

PRODUCT:	F-605UW	
DWG #:	F-605UW-2	
SCALE:	1:10	DATE: 2/5/15
DRAWN BY:	KR	REVISION: C

UNDER WATER WALKER

SPECIFICATIONS:

OVERALL HEIGHT (MAX): 50-1/4" [1276mm] (MIN): 37-1/4" [946mm]
MAX. WIDTH (CENTER OF PVC PIPES): 22" [559mm]

WEIGHT: 26lbs [12kg]

FEATURES:

3" ARM RESTS, PVC
(4) SWIVEL CASTERS, (2) NON-LOCKING & (2) LOCKING

MATERIALS:

FRAME: PVC, FURNITURE GRADE
CASTERS: STAINLESS STEEL FRAME, 3" SOLID RUBBER WHEELS
(4) LOCK PINS: 18-8 STAINLESS STEEL, 1/4" X 2 1/4" SQUARE LOOP



Aqua Creek Products

The Total Solution for Pool and Spa Access

9889 GARRYMORE LANE
MISSOULA, MT 59808
(406) 549-0769
FAX (406) 549-2602

NOTE:
*SPECIFICATIONS ARE SUBJECT TO CHANGE WITHOUT NOTICE

PRODUCT:	F-605UW	
DWG #:	F-605UW-3	
SCALE:	1:1	DATE: 2/5/15
DRAWN BY:	KR	REVISION: C