

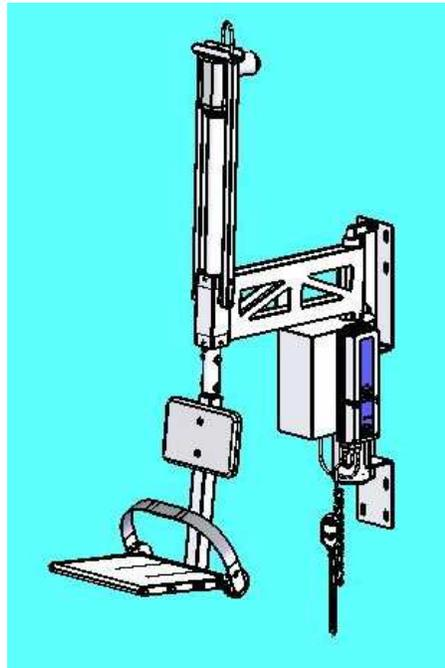

Aqua Creek Products

The Total Solution for Pool and Spa Access



ABLE BATH LIFT

PART NUMBER: F-25ABLE

(Aquatic-Bath-Lift-Elite)

300LBS [136 kg] MAXIMUM CAPACITY

MANDATORY - LEAVE THIS MANUAL WITH LIFT OWNER

- WARNING -

IMPORTANT SAFETY INSTRUCTIONS

- 1. READ AND FOLLOW ALL INSTRUCTIONS. LIFT SAFETY CAN ONLY BE ENSURED IF THE LIFT IS INSTALLED AND OPERATED PROPERLY – ACCORDING TO THESE INSTRUCTIONS.**
- 2. TO REDUCE THE RISK OF INJURY, DO NOT PERMIT CHILDREN TO USE THIS PRODUCT UNLESS THEY ARE CLOSELY SUPERVISED AT ALL TIMES.**
- 3. DO NOT PERMIT CHILDREN TO PLAY ON OR AROUND THIS PRODUCT.**
- 4. NEVER APPLY DIRECT WATER PRESSURE TO THE ELECTRONIC COMPONENTS.**
- 5. SAVE A COPY OF THESE INSTRUCTIONS IN A SAFE AND EASILY ACCESSIBLE PLACE.**

9889 GARRYMORE LANE

MISSOULA, MT 59808

1-888-687-3552

FAX: 406-549-2602

MOST IMPORTANT: Carefully inspect the lift upon arrival, noting any damage or missing parts on the delivery receipt before the delivery truck driver leaves. If there is damage or missing parts, get a contact name and phone number from the truck driver and inform him that you will need to file a claim. Contact the trucking company immediately. Then contact Aqua Creek Products at 888-687-3552. We will assist you in filing a claim and replacing missing or damaged parts. If you discover concealed damage after the delivery driver has left, call the trucking company immediately. You have only three days to report concealed damage to the trucking company.

Your ABLE Bath Lift will arrive partially pre-assembled in a crate. Remove the parts from the crate and place them near to the location where the lift will be installed.

PARTS LIST:

- [A] Main Assembly (1)
- [B] Pivot Arm Assembly (1)
- [C] Actuator Frame Assembly (1)
- [D] Linear Actuator (1)
- [E] Folding Seat with Seatbelt (1)
- [F] 24V Control Box (1)
- [G] 24V Battery (1)
- [H] Handset Control (1)
- [I] Battery Charger & Mtg. Bracket

HARDWARE INCLUDED:

- 3/8" Flat Washer, SS (8)
- 3/8" Nylock Nut, SS (8)

HARDWARE NOT INCLUDED:

- Wall Bracket (2) [PN: F-2600]
- 3/8" x 7" Hex Bolt, SS (4)
- 3/8" Flat Washer, SS (8)
- 3/8" Nylock Nut, SS (4)

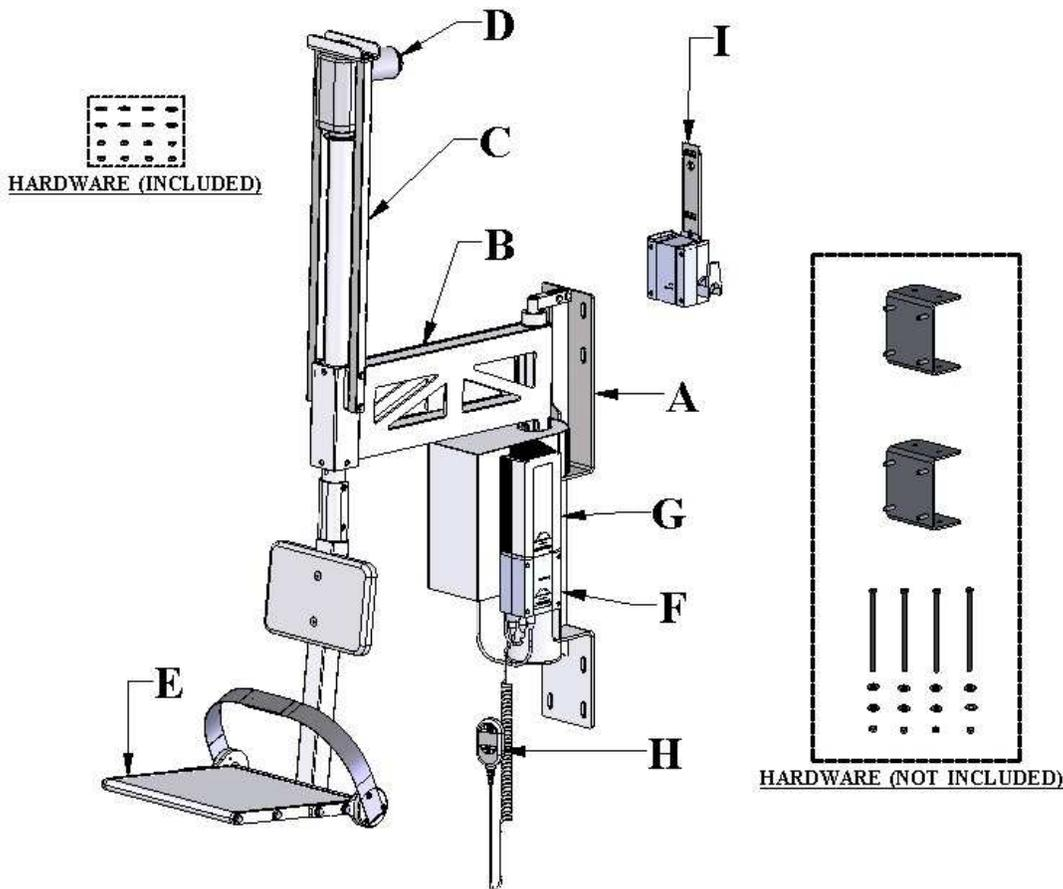

INSTALLATION INSTRUCTIONS:

STEP 1: DETERMINE LOCATION OF LIFT

The Able Bath Lift comes with two (2) wall mounting brackets. The wall-mounting brackets must be installed as shown here to ensure that there will be ample support for the lift. In order to install the brackets a section of the wallboard must be removed and braces must be added as shown in **FIGURE 3** or **FIGURE 3A**. The braces are shown constructed from 2X4 lumber, but may be the same size as the lumber used in the wall section (2X4 or 2X6) and should be secured to the existing studs with 8P common nails or screws. The shower curtain-rod will need to be moved up to 92" as shown.

The general requirements for the installation are:

1. THE BATHTUB CAN BE NO MORE THAN 22" [560 mm] HIGH
2. THE CEILING MUST BE AT LEAST 8 FEET [2.4 meters] HIGH
3. THERE MUST BE ONE CLEAR ADJASCENT WALL FOR MOUNTING

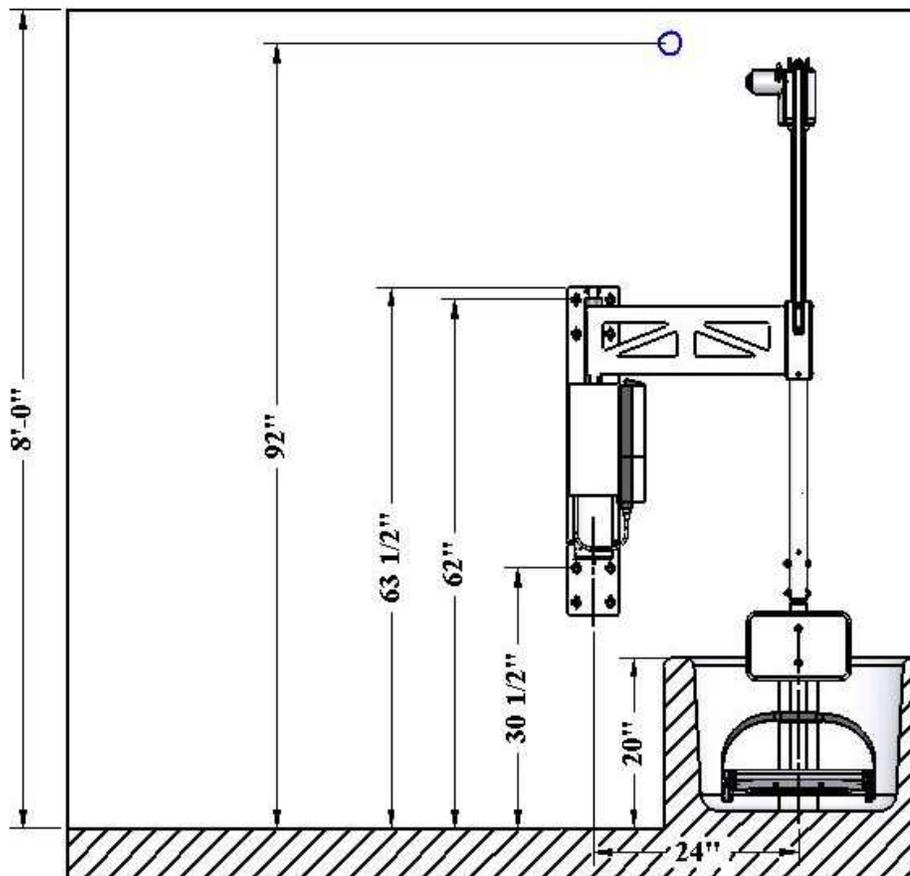

FIGURE 1: TYPICAL INSTALLATION

NOTES ON TYPICAL INSTALLATION:

The installation shown in FIGURE 1 and FIGURE 2 is just one possible installation. But for all installations the following holds true:

1. THE ABLE BATH LIFT MAY BE ON EITHER SIDE OF THE BATHTUB.
2. THE WHEELCHAIR-LOADING MAY TAKE PLACE AT ANY LOCATION.
3. THE CENTER-TO-CENTER DISTANCE SHOULD BE 24 INCHES (OR LESS).
4. THE ABLE BATH LIFT SHOULD BE INSTALLED OPPOSITE TO THE FAUCET.

The Able Bath Lift can go over certain obstacles, such as a commode, so it is possible to have other objects along the path of the lift – as long as there is room for the chair and the occupant to clear the obstacle. But in general the area should be clear.

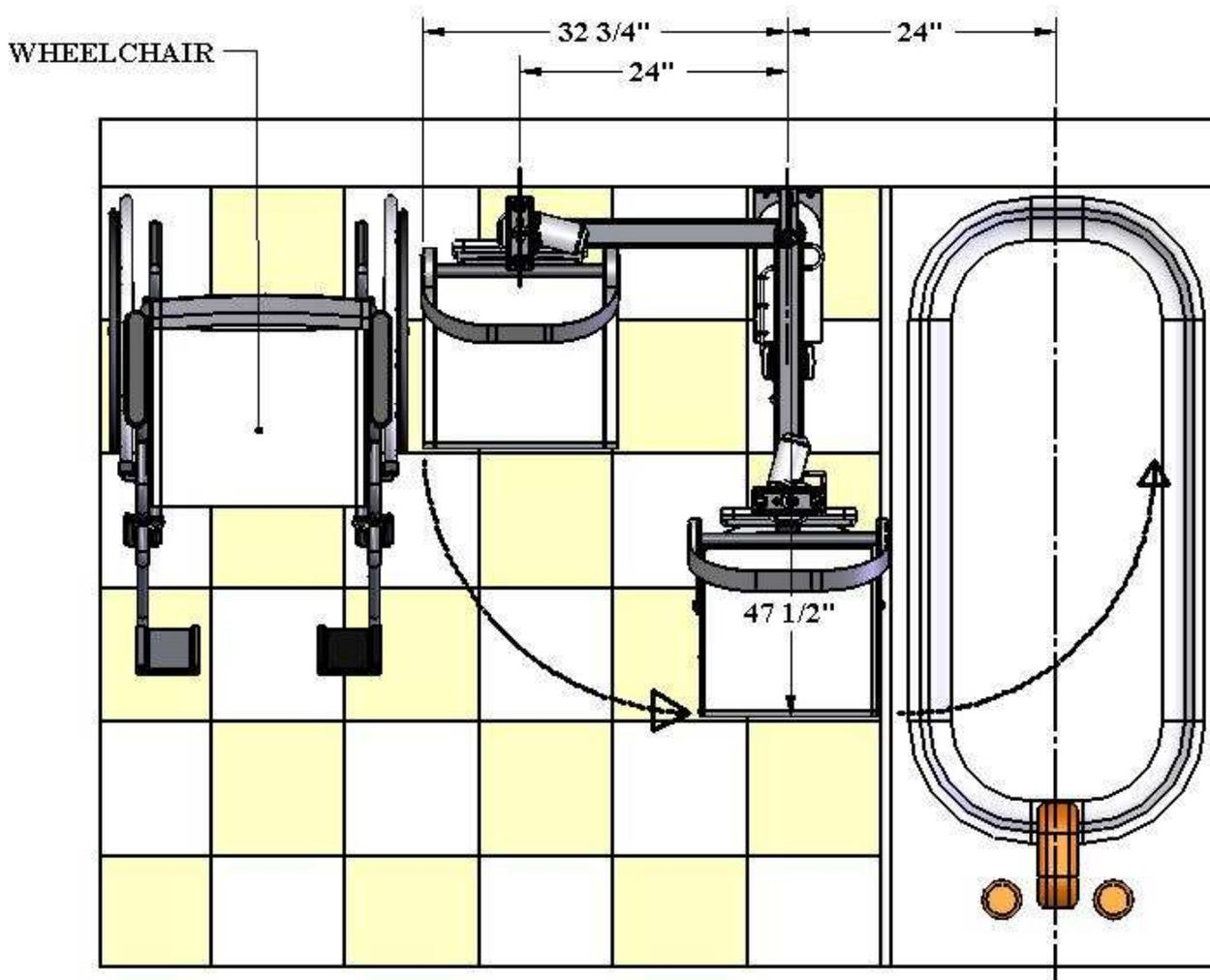
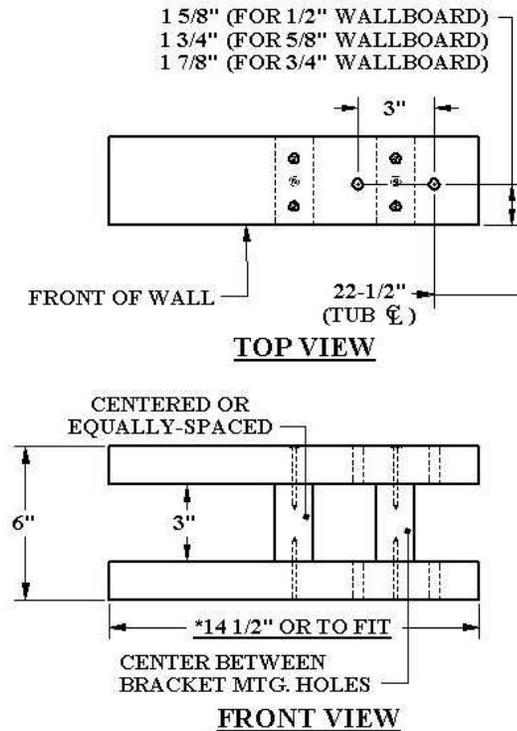
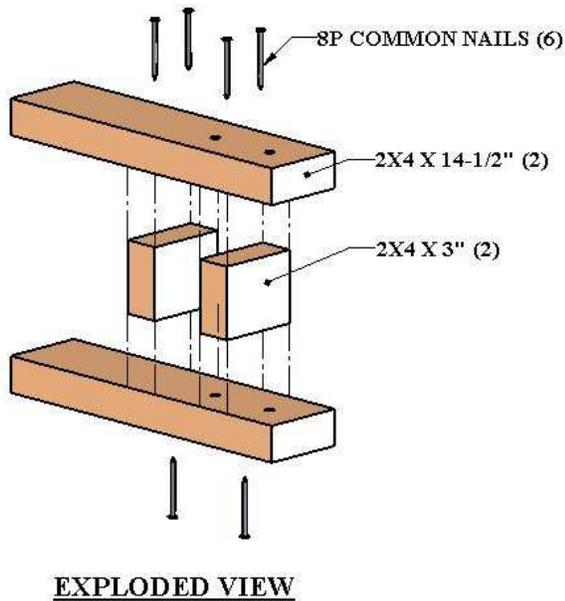

FIGURE 2: TYPICAL INSTALLATION (PLAN VIEW)

STEP 2: CONSTRUCT WALL BRACES & ATTACH BRACKETS (NOTE – ONLY IF BRACKETS FIT BETWEEN WALL STUDS – OTHERWISE SEE FIGURE 3A)

[2-A] Assemble two (2) braces from 2X4* lumber and 8-penny nails as shown. These braces are sized to fit between two wall studs @16" C-C.

*NOTE: THESE BRACES MAY ALSO BE CONSTRUCTED FROM 2X6 LUMBER IF WALL IS 2X6.



[2-B] Attach the WALL BRACKETS to the braces using the 3/8" hex bolts and hardware as shown. Tighten the hardware thoroughly, but don't crush the braces (too tight!).

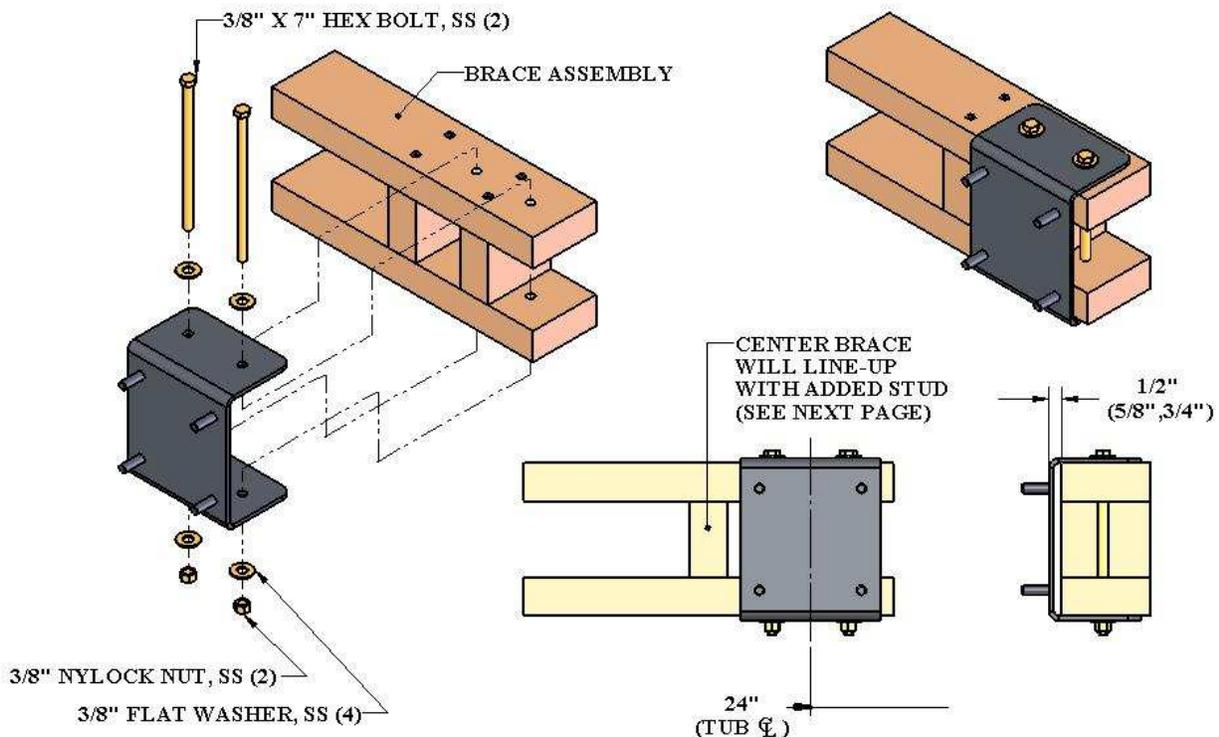

STEP 3: INSTALL WALL BRACES & WALL BRACKETS

The WALL BRACKETS, installed on WALL BRACES from STEP 2, will next be mounted inside the wall. FIGURE 3, below, shows an overview of the installation details. See the next page for STEP-BY-STEP instructions.

NOTE: The center-to-center distance, measured from the centerline of the bathtub to the centerline of the WALL BRACKETS, is 24" maximum. If this distance is much more than 24" there is a chance the seat will not clear the near-wall of the bathtub. This distance (24") may be reduced for instances where the seat can't rotate and extend to a full 24" (obstacle) or when the final position of the seat needs to be more towards the middle of the bathtub (as opposed to against the adjacent wall). Refer to FIGURE 2 for a better idea of what a shorter center-to-center dimension would do to your installation. **MAKE SURE THIS DISTANCE IS CORRECT BEFORE INSTALLING THE WALL BRACKETS.** This is a case where you want to be absolutely sure – you only want to do this part once! Also, note that the bracket may be placed anywhere along the 14-1/2" space between the studs, which gives you 9" of adjustment range. For instances where this is not enough, the bracket may be rotated 90° and mounted over a stud (see FIGURE 3A). When the wall brackets have been installed the wallboard should then be replaced. **THE BRACKETS SHOULD BE FLUSH WITH THE FINISHED WALL AND WITH EACH OTHER.** This is also very important, because the MAIN ASSEMBLY of the lift must be level and plumb.

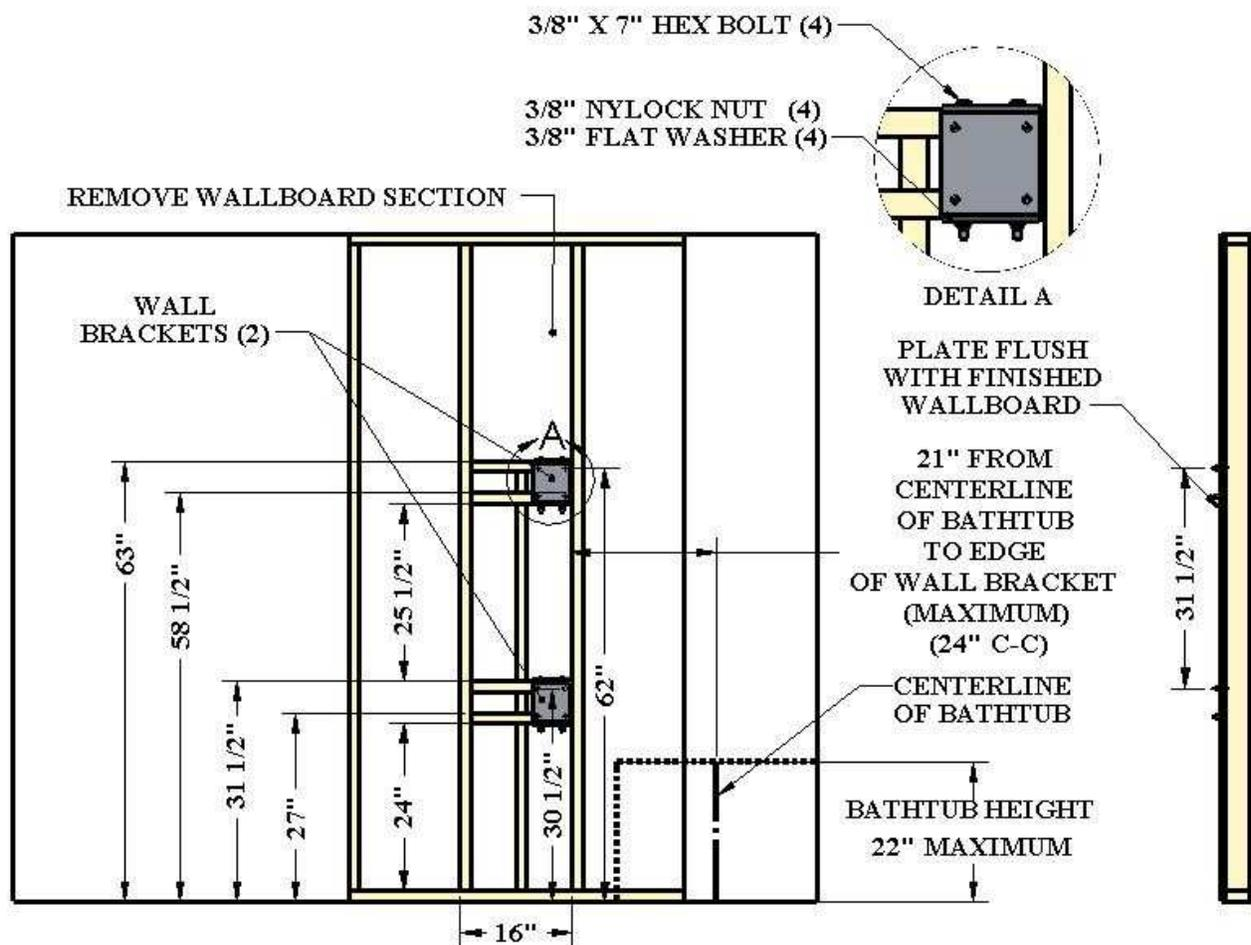
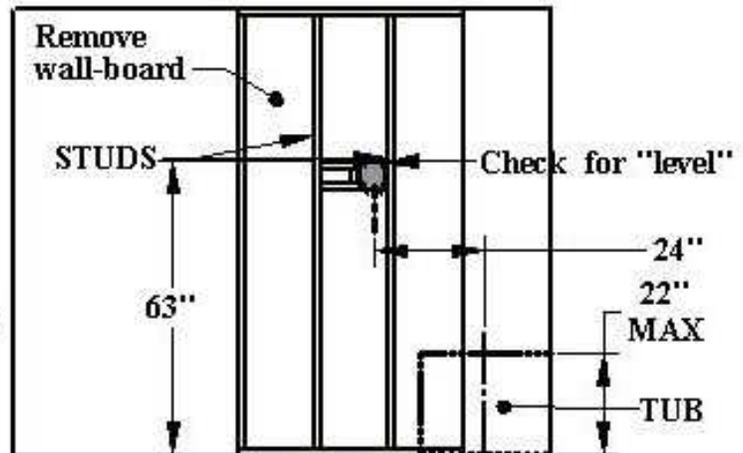

FIGURE 3: TYPICAL WALL-BRACKET INSTALLATION

STEP 3: DETAILED INSTRUCTIONS (STEP-BY-STEP)

- [3-1]** Attach one BRACE-ASSEMBLY between two wall studs as shown. Attach to the studs with 8-P common nails (8). The top of the upper brace will be 63" above the finished floor. Check the center-center distance (tub to bracket), it should be 24" (or less).

HINT: Place a "Torpedo-Level" (short) on top of the brace assembly and check for level BEFORE nailing it to the wall studs.



- [3-2]** Slide the 2nd BRACE-ASSEMBLY into position beneath the first. The top of the 2nd brace should be 31 1/2" above the finished floor, or 25-1/2" between the two braces. Place a carpenter's level (long) along the left side of both brackets and make sure the mounting-studs are lined up (bubble in center). If not, trim the bracket and shift until level. Shim, if necessary, and then attach to the studs with 8-P common nails.

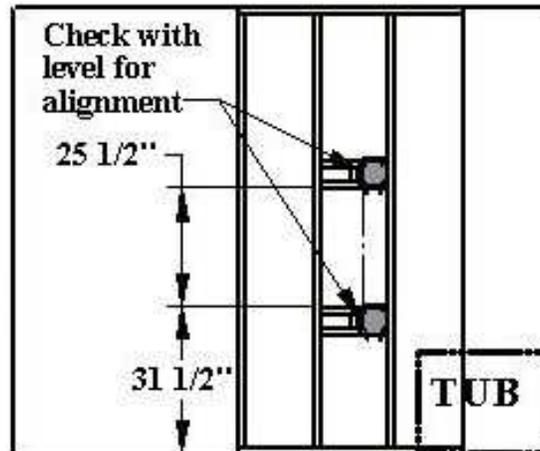

- [3-3]** Add "CRIPPLE" studs between the braces and extending to the floor. Line-up the "CRIPPLE" studs with the middle-braces as shown. Attach with 8-P common nails.

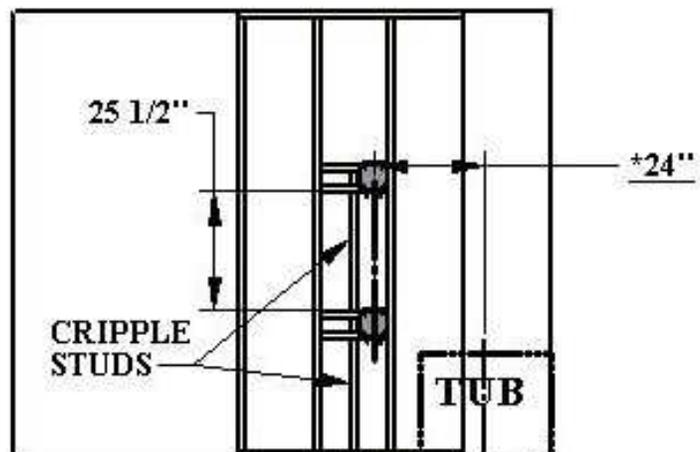

***NOTE:** THIS INSTALLATION SHOWS THE TUB ON THE RIGHT, BUT THE REVERSE IS ALSO CORRECT. (CENTER TO CENTER = 24" MAX)

STEP 3A: ALTERNATIVE WALL-BRACKET INSTALLATION

For instances where the wall stud is in the way of installing the wall bracket as shown in FIGURE 3, the brackets may be rotated 90° and mounted over the stud. Therefore it should be possible using either FIGURE 3 or FIGURE 3A to position the wall brackets properly, with a center-to-center distance of not more than 24".

NOTES ON ALTERNATIVE INSTALLATION:

1. THE WALL BRACKETS ARE TURNED 90° TO FIT OVER THE WALL STUD.
2. FOR ADDED STRENGTH, ONE OR MORE OF THE 2X4 VERTICAL BRACES MAY BE EXTENDED TO THE PLATE (FLOOR)
3. BY USING BRACES OF DIFFERENT THICKNESS, THE WALL BRACKET SPACING MAY BE ADJUSTED UP TO 4-1/2" SIDE-TO-SIDE.
4. THE SPACING FROM THE NEAR-EDGE OF THE BRACKETS TO THE BATHTUB CENTERLINE IS NOW 20-1/2" (MAX). CENTER-TO-CENTER IS STILL (ALWAYS) 24" MAXIMUM.

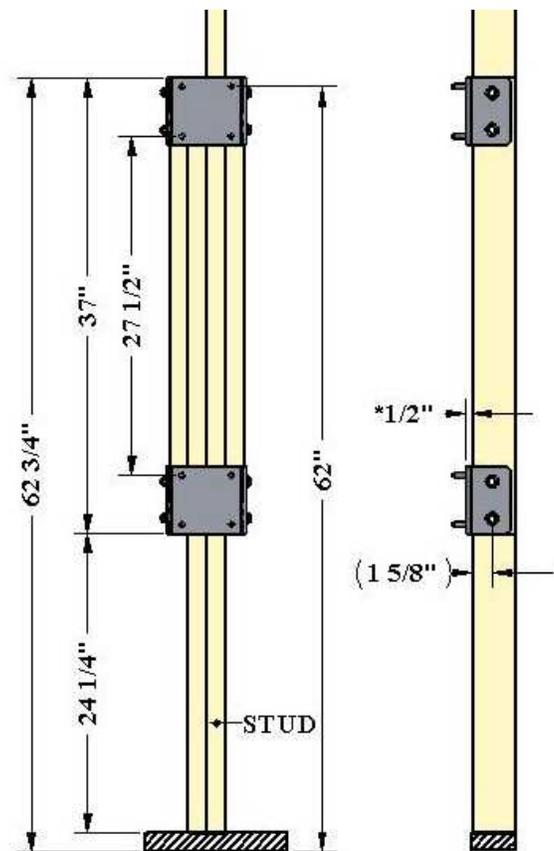
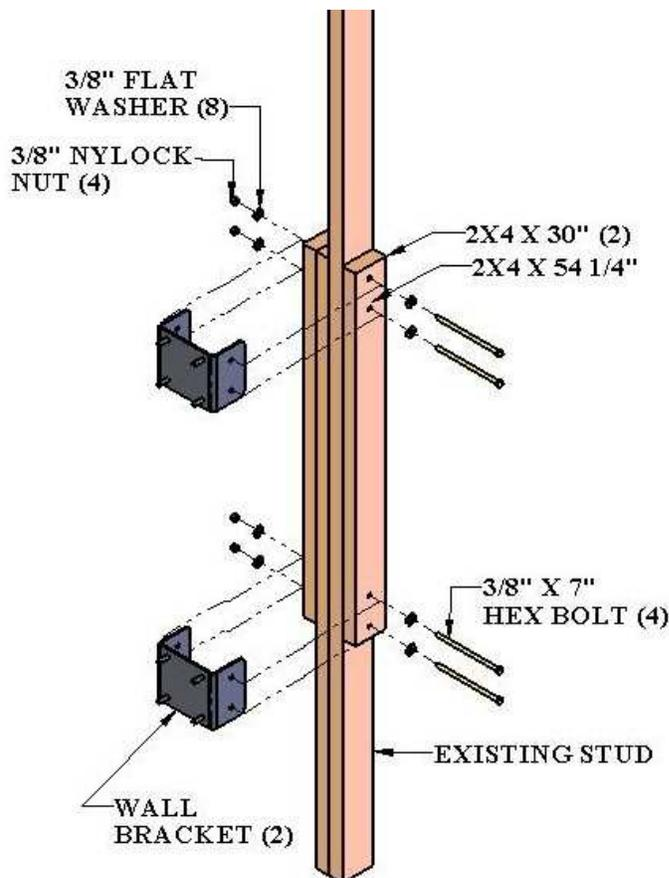
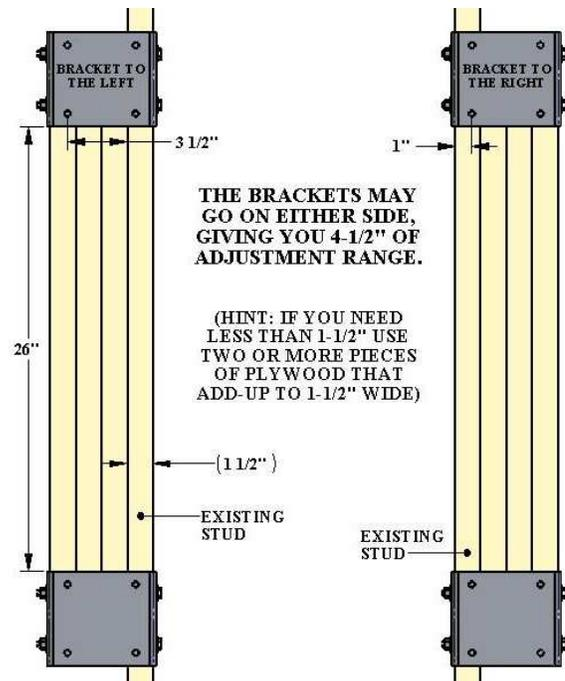

* SAME AS WALLBOARD THICKNESS

FIGURE 3A: ALTERNATIVE WALL BRACKET INSTALLATION

ABLE: LIFT INSTALLATION INSTRUCTIONS

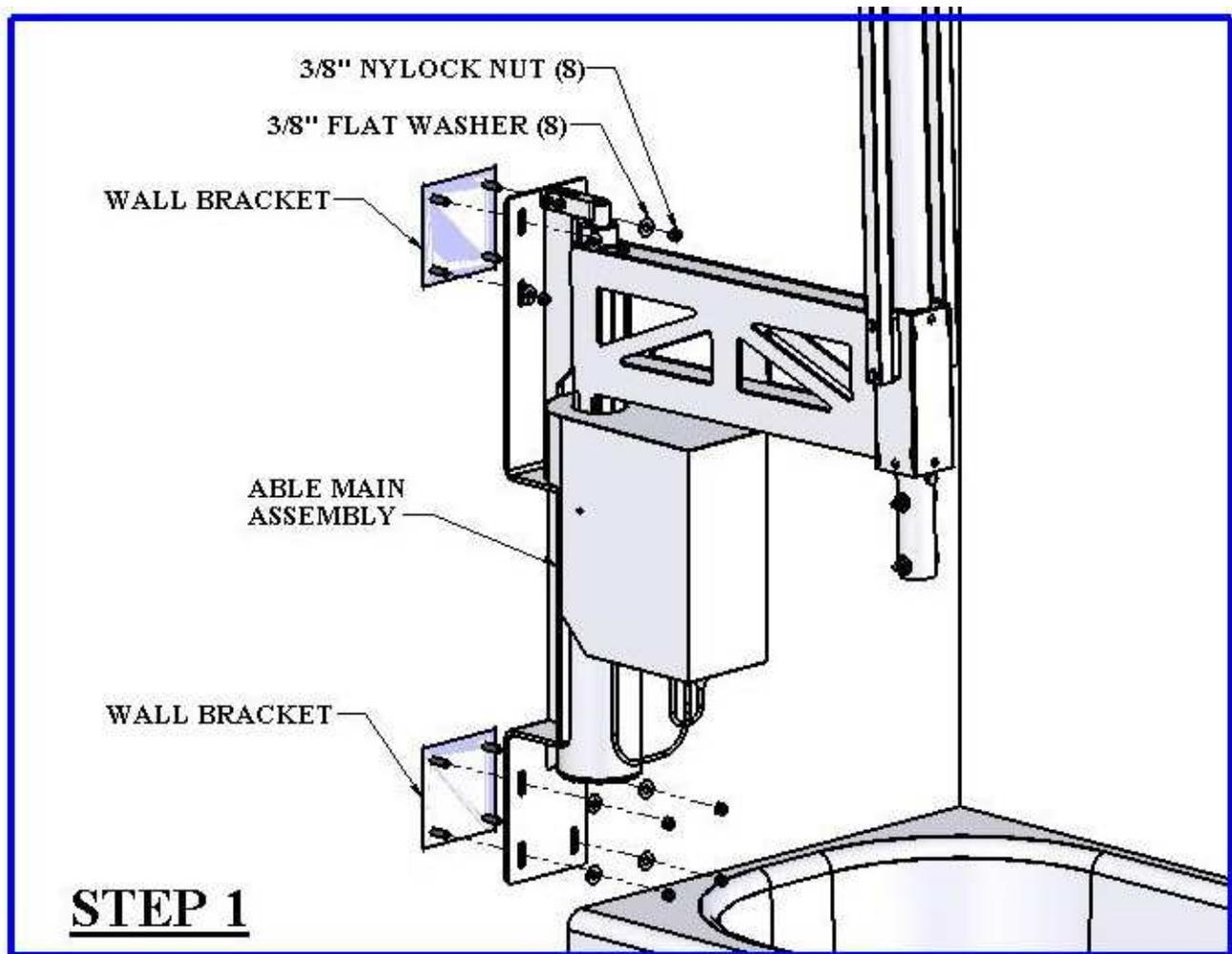

**WARNING! THIS ASSEMBLY IS VERY HEAVY!
A MINIMUM OF TWO PEOPLE IS REQUIRED!**

Once the wall-brackets have been installed and the wall is restored to finished state the ABLE Bath lift can be installed onto the wall. Start by bolting the MAIN ASSEMBLY to the wall as shown using;

(8) 3/8" FLAT WASHERS (STAINLESS STEEL)

(8) 3/8" NYLOCK NUTS (STAINLESS STEEL)

Put a level on the top of the main assembly and tilt until the bubble is centered. Tighten the nylock-nuts using a 9/16" wrench or socket.

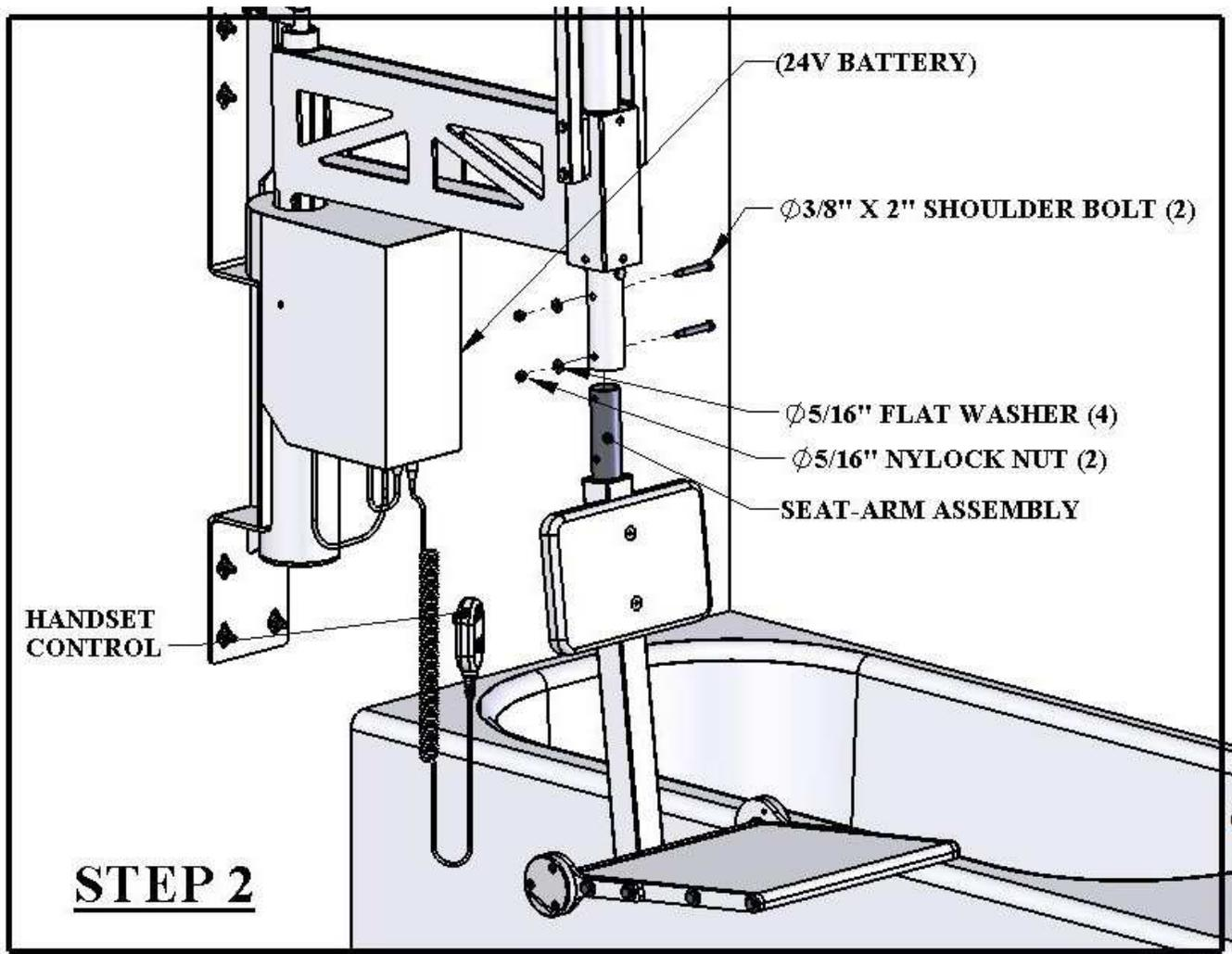

Next attach the SEAT ARM ASSEMBLY to the MAIN ASSEMBLY as shown, using;

- (2) 3/8" X 2" SHOULDER BOLTS (STAINLESS STEEL)
- (4) 5/16" FLAT WASHERS (STAINLESS STEEL)
- (2) 5/16"-18 NYLOCK NUTS (STAINLESS STEEL)

Tighten the nuts until snug, using 1/2" wrenches and/or sockets.

LIFT WIRING:

The lift will arrive completely wired, but the handset cable needs to be installed properly before the lift will function. The diagram below shows the basic wiring diagram for the ABLE Bath Lift.

Install the handset cable as shown, with the tab to the front as you insert the plug into the socket. Push firmly upwards until the plug is fully seated. The lift will not function if the plugs are not fully seated.

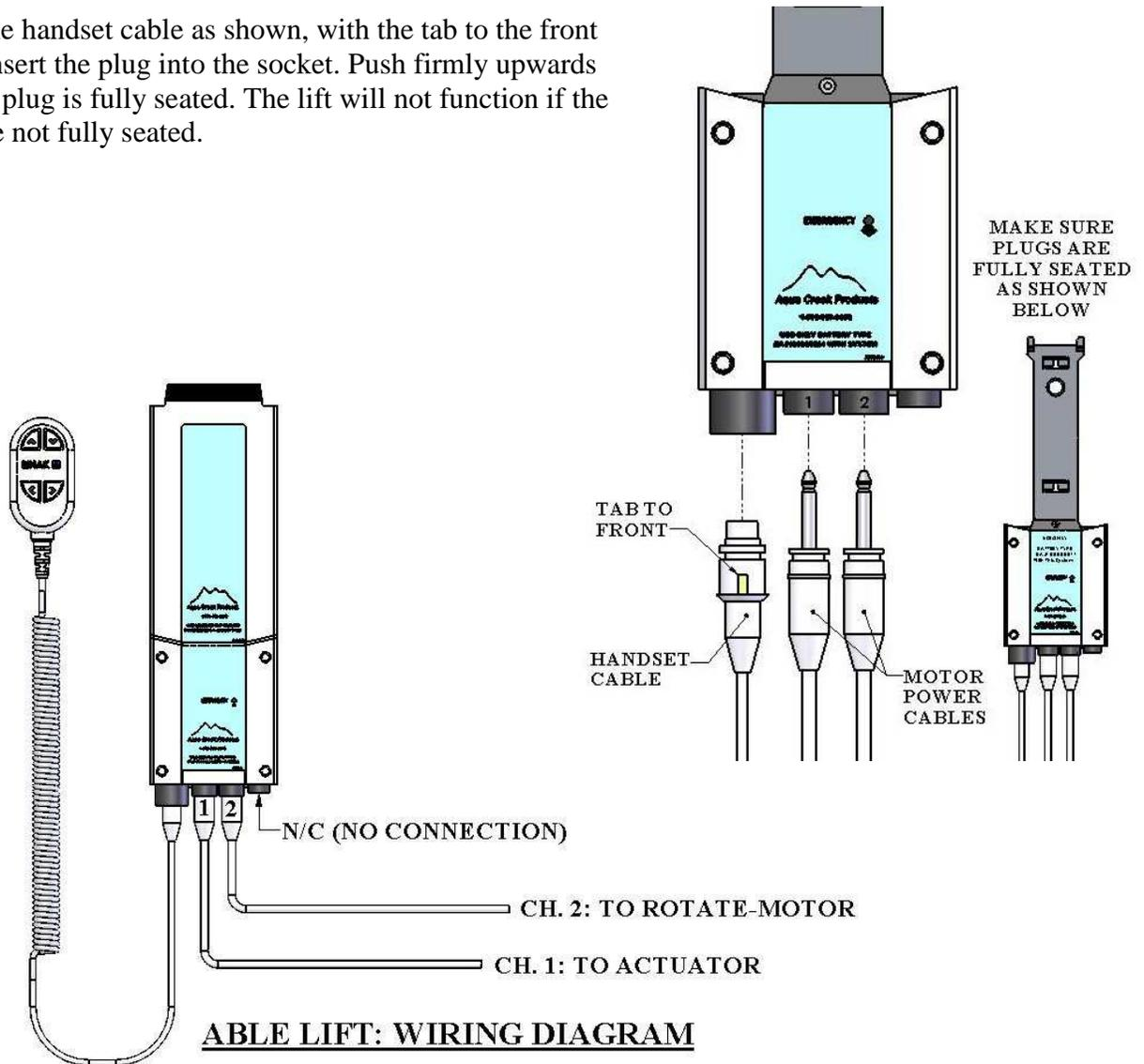

Remove the charger and the battery from the equipment box, and place the charger where it can be conveniently plugged into a 115v outlet.

Place the battery on the charger and charge it for **24 HOURS** before attempting to operate the lift. **WHEN NOT IN USE THE BATTERY CAN BE STORED ON THE CHARGER.**

OPERATING INSTRUCTIONS: THE ABLE BATH LIFT



WARNING: READ THIS SECTION THOROUGHLY BEFORE ATTEMPTING TO USE OR OPERATE THIS PRODUCT!!!

The ABLE Bath Lift is designed for optimal flexibility and functionality, and when used properly can make bathing a simple pleasure again for handicapped and physically challenged individuals. Note that the seat itself pivots 360° for maximum usability, and that the user may position the seat at any height and/or rotational-angle necessary to negotiate obstacles or features in the facility. Therefore be advised that these instructions are intended to provide a general understanding of the features and capabilities of the ABLE Bath Lift, and do not represent a totally comprehensive guide to all possible uses and applications. But in any case this section should be read and reviewed thoroughly by all intended users and operators before attempting to use the ABLE Bath lift.

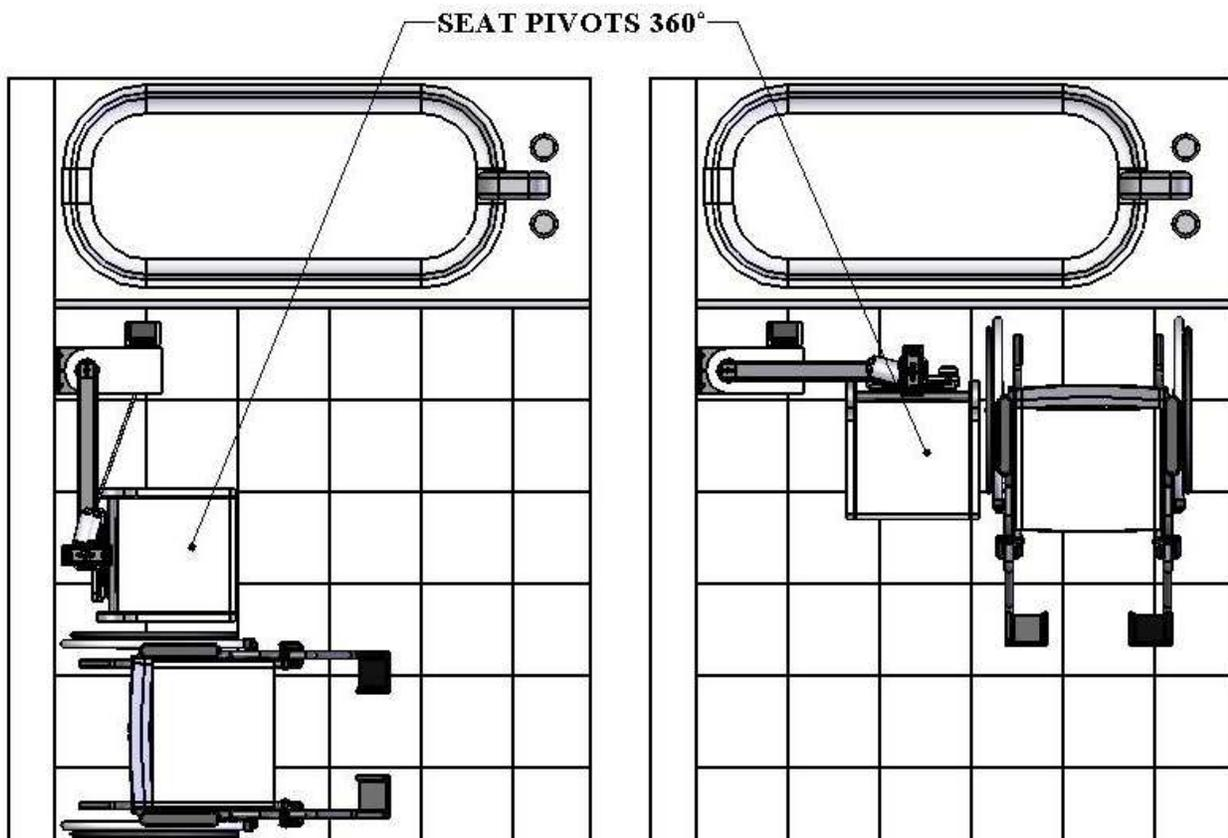

THE SEAT PIVOTS 360°, SO TRANSFER CAN BE DONE FROM ANY ANGLE

The diagram above shows how transfer to the seat can be done from any direction. Pivot the seat to the position that makes transfer most convenient and then roll the wheelchair up next to or in front of the seat. Remember to fasten the seatbelt once transfer has been accomplished.

Note that the seat will often need to be rotated as the unit rotates to position it squarely over the bathtub. This also allows the user to start in one position and rotate the seat into another for actual bathing. This step may require operator assistance, or grab-rails may be installed along the wall to make this process self-sufficient. All of this is contingent on the capabilities and mobility of the patient/user, but always remember that the seat pivots manually.

USER ROTATES THE SEAT 180° CLOCKWISE AS THE PIVOT-ARM ROTATES 180° COUNTER-CLOCKWISE

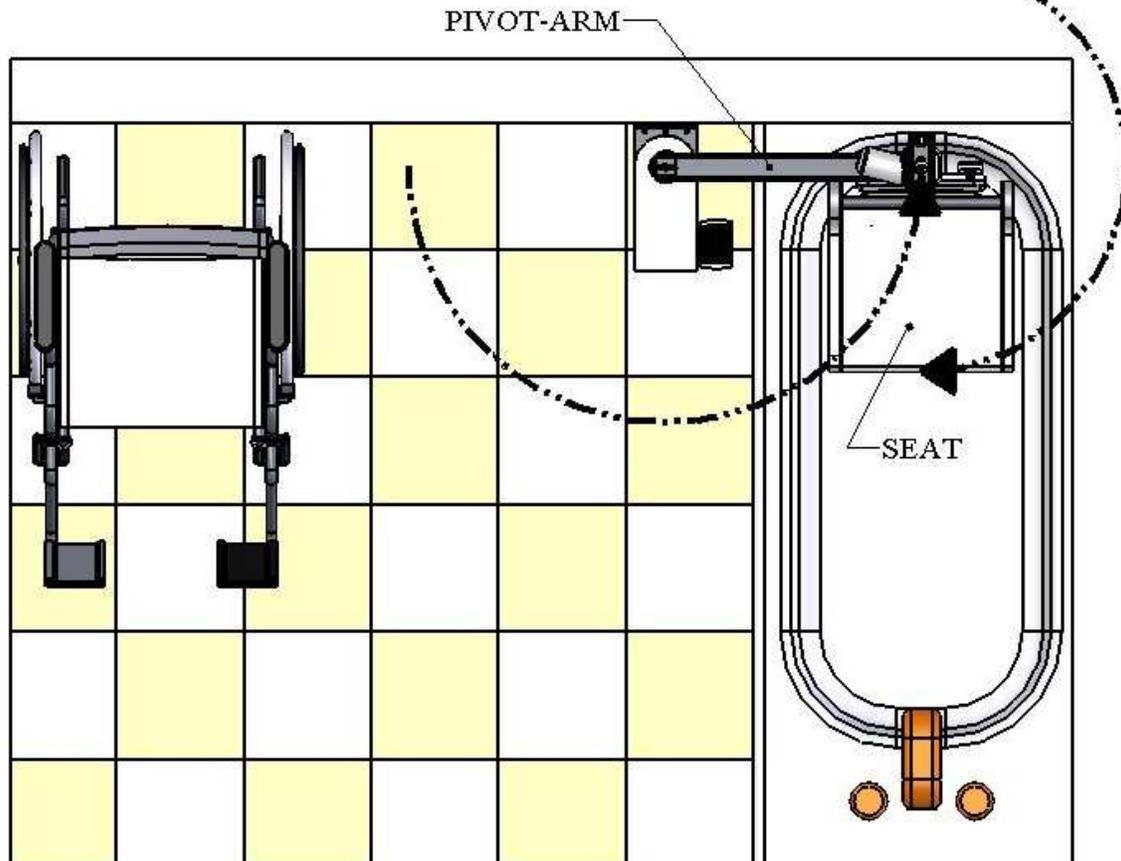

ONCE ROTATED AND ORIENTATED OVER THE BATHTUB, THE SEAT IS LOWERED

Shown above is a typical situation where the user must rotate the seat 180° as the pivot-arm swings the lift over the bathtub. Once the seat is properly positioned over the bathtub it may be lowered down into the water. In some instances the seat may not need to be rotated, but in any case it should end up in the position shown above, or in a similar position for other configurations.

WARNING: MAKE SURE THE SEATBELT IS SECURELY FASTENED BEFORE MOVING.

All maneuvering is done using the handset control, which has four buttons (UP, DOWN, ROTATE LEFT, ROTATE RIGHT). The buttons are all 'HOLD TO OPERATE' type controls. Therefore, in order to move the seat up press and hold the "UP" button until the desired height is reached. Release the button. The lift will not move unless a button is depressed and held. Do not push more than one button at a time, to avoid complications.

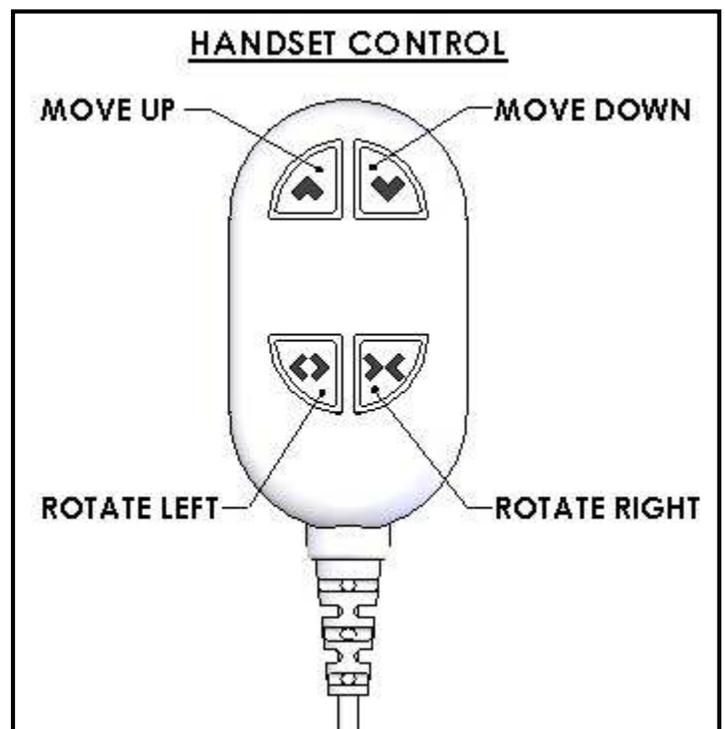

BATTERY SYSTEM OPERATING AND INSTALLATION INSTRUCTIONS

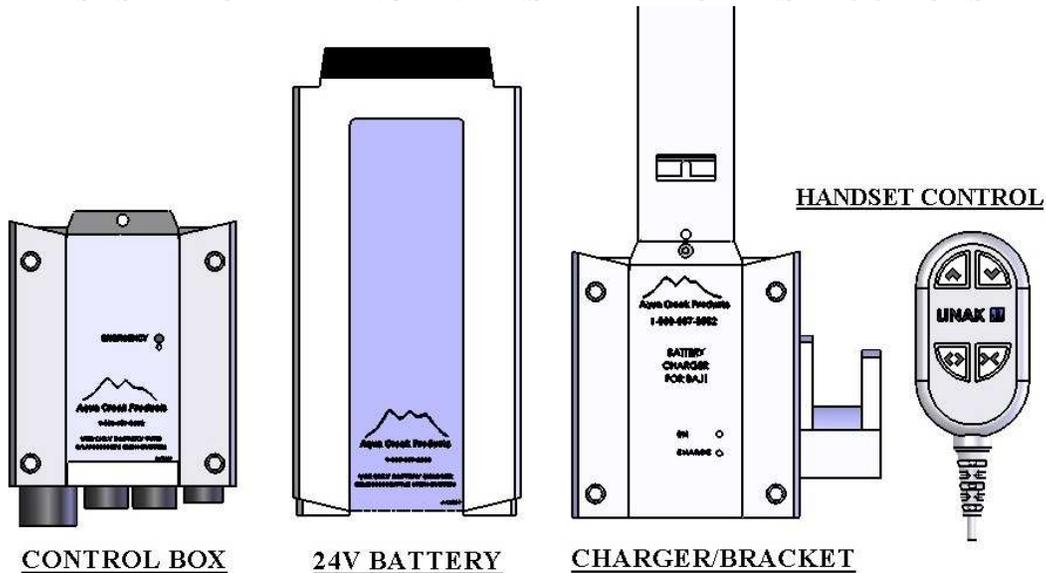

The Able Bath Lift Battery system comes with a 24v sealed rechargeable battery, wall mount charging unit (with mounting bracket), control box, and a waterproof handheld controller. The control box is mounted to the Able Bath Lift and has a plug-in socket for the actuator, the rotate motor and the handheld controller. The battery mounts directly above the control box with a quick-release clip.

The lift should be able to complete approximately 10-20 full cycles before the low battery signal will sound. The low battery signal indicates approximately 20% battery life remaining. At this point, it is suggested that the battery be removed from the unit and recharged on the wall mount-charging unit.

To recharge the battery, simply grip the top of the battery and depress the clip on the back of the battery. This will unclip the battery from the control box bracket and the battery can then be clipped into the wall mount charger. When the battery is correctly mounted to the charger, the **CHARGE** light will illuminate. When the battery is fully charged, the **CHARGE** light will **GO OFF** and you can return the battery to the Able Bath Lift.

APPLYING DIELECTRIC GREASE: In order to keep the battery/control box terminals from corroding a small packet of dielectric grease has been provided with the Able Bath Lift. The lift will arrive with dielectric grease already applied to the terminals, but it is recommended that more grease be applied to the terminals every 6 months, or as often as needed to keep the terminals corrosion free. Apply the grease as shown in the figure below.

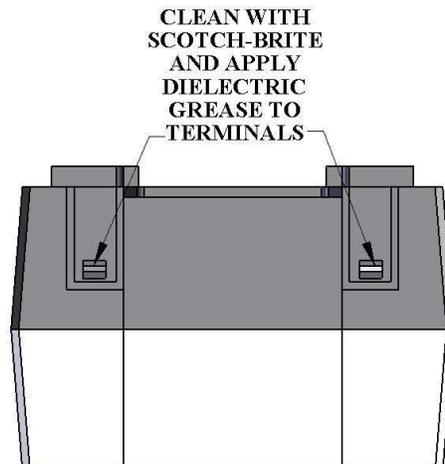

AQUA CREEK PRODUCTS

LIBERTY LIFT TROUBLESHOOTING GUIDE

PROBLEM:

CAUSE:

SOLUTION:

1. Lift will not move when remote buttons are pushed.

Remote Control Unit is not plugged in properly (Fig 1)

Remote Power cord must be inserted deeper into the socket on the bottom of the control box (Fig 2)

Figure 1



Actuator cord not is not plugged in completely (Fig 3)

Figure 2



Acuator Cord must be inserted deeper into the Socket #1 on the bottom of the Control Box (Fig 4)

Figure 3

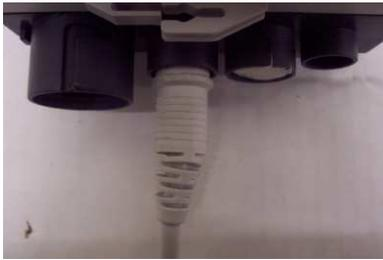

Figure 4



2. No power to Control Box

Battery not fitted properly on Top of Control Box (Fig 5)

Check alignment of battery to to Control Box (Fig 6)

Figure 5



Battery incorrectly aligned

Figure 6

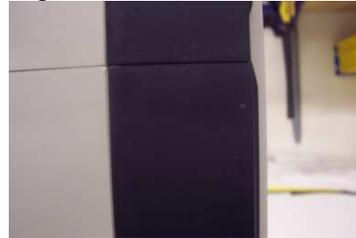

Battery correctly aligned on top of Control Box

Battery to Control Box Mounting Bracket:

Figure 7



Battery NOT Correct Attached

Figure 8



Battery Correctly Attached

3. No Power from Battery to Control Box

Corroded Terminals

Clean Battery Terminals and Charger Terminals.

Figure 9



Battery Contact Terminals

Figure 10



Charger Contact Terminals

4. Charger is not charging the Battery

Battery is not aligned properly on top of Charger. (Fig 11)

Check alignment of Battery to Charger and adjust. (Fig 12)

Figure 11



Battery NOT correctly aligned on top of Charger.

Figure 12

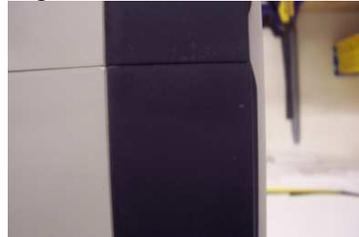

Battery correctly aligned on top of Charger. Note no gap in seam between Battery and Charger.

ABLE BATH LIFT: PARTS DIAGRAM

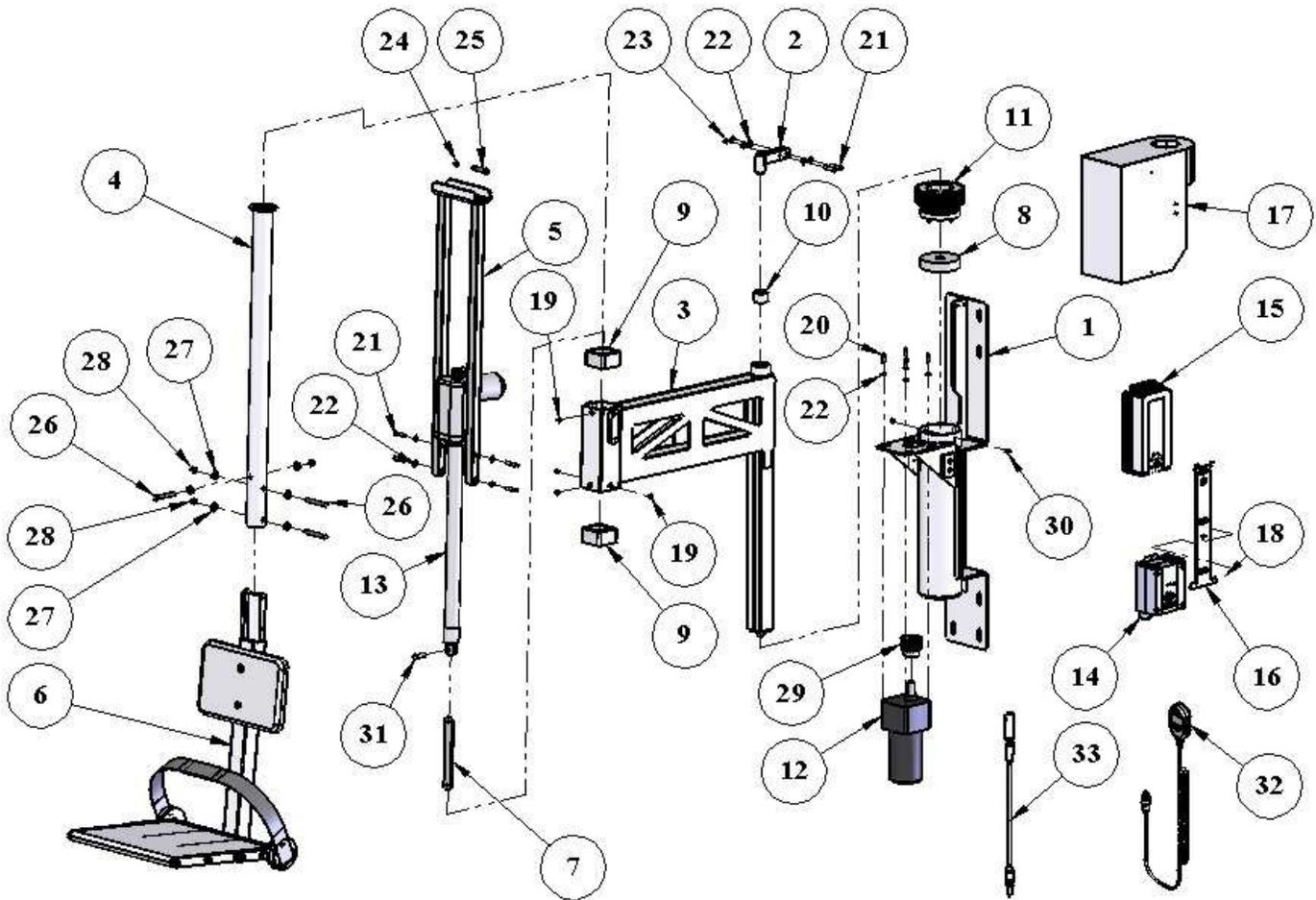

ITEM #	QTY.	PART NUMBER	DESCRIPTION
1	1	PTL-100-50	MAIN FRAME ASSEMBLY, ABLE LIFT
2	1	PTL-100-4-20	PIVOT BRACKET, ABLE LIFT
3	1	PTL-200-50	BRACKET ASSEMBLY, ABLE LIFT
4	1	PTL-300-10	PIVOT TUBE ASSEMBLY, ABLE LIFT
5	1	PTL-600-30	ACTUATOR FRAME, ABLE LIFT
6	1	PTL-400A-11	SEAT-ARM ASSEMBLY, ABLE LIFT
7	1	PTL-630-30	LINKAGE BAR, ABLE LIFT
8	1	PTL-180-00	BEARING, UHMW PLASTIC, PIVOT BEARING, MACHINED, ABLE LIFT
9	2	PTL-185-00	BUSHING, UHMW PLASTIC, SEAT PIVOT, MACHINED, ABLE LIFT
10	1	PTL-186-30	BRACKET, PLASTIC, HDPE, WHITE, TOP PIVOT, ABLE LIFT
11	1	SA-ROTATE C-G ASSY	ABLE ROTATE GEAR ASSEMBLY
12	1	6155/REV/TITAN	MOTOR, GROSCHOPP, (930-60-3340)
13	1	340652-00	ACTUATOR, 500MM, LINAK, ABLE LIFT
14	1	F-41CBJ	CONTROL BOX, 2-PORT, REVOLUTION, SCOUT, TITAN AND PRO SPA SERIES
15	1	F-004AB	BATTERY, 24V (2PC CONTROLS)
16	1	MBJ2-01	BRACKET, MOUNTING, T SHAPED FOR CONTROL BOX
17	1	PTL-800-20	SHROUD, MOTOR, ABLE LIFT
18	1	BOLT, 10-24 X 1/2 LPCS	BOLT, 316 SS, 10-24 x 1/2 LPCS
19	4	BB 1/4 X 3/8	BOLT, 316 SS, 1/4-20 X 3/8 BHSCS
20	4	BH 1/4 X 1	BOLT, 316 SS, 1/4-20 X 1 HCS
21	6	BH 1/4 X 1-3/4	BOLT, 316 SS, 1/4-20 X 1 3/4 HCS
22	12	WF 1/4	WASHER, FLAT, 1/4, 316 SS
23	2	NN 1/4	NUT, 316 SS, NYLOCK, 1/4"-20
24	1	NN 5/16	NUT, 316 SS, NYLOCK, 5/16"-18
25	1	BS 3/8 X 1-1/4	BOLT, 316 SS, 3/8 X 1 1/4 SHOULDER, 5/16-18 THREAD
26	3	BH 3/8 X 3	BOLT, 316 SS, 3/8-16 X 3 HCS
27	6	WF 3/8	WASHER, FLAT, 3/8, 316 SS
28	3	NN 3/8	NUT, 316 SS, NYLOCK, 3/8"-16
29	1	PTL-196-00	GEAR, PLASTIC, MOTOR, ABLE LIFT
30	2	BB 1/4 X 3/8	BOLT, 316 SS, 1/4-20 X 3/8 BHSCS
31	1	BH 3/8 X 1-1/4	BOLT, 316 SS, 3/8-16 X 1 1/4 HCS
32	1	F-104JH	HANDSET, 4-BUTTON, PRO SPA SERIES, SCOUT, ABLE, REV & TITAN
33	1	032628	CABLE, EXTENSION, CUSTOM CABLE FOR ACT TO CONTROL BOX

AQUA CREEK PRODUCTS, LLC LIMITED FIVE (5) YEAR WARRANTY:

ABLE BATH LIFT

(ITEM #: F-25ABLE)

Aqua Creek Products, LLC (a.k.a. Aqua Creek) also warrants to the original end user purchaser that products manufactured by Aqua Creek, when properly installed in accordance with assembly and installation instructions, and properly used and maintained, shall be free from defects in material and workmanship for a period of five (5) years from the date of original purchase, provided that Aqua Creek receives prompt notice in writing of any defect or failure and satisfactory proof thereof, with the following exception(s):

Exceptions:

- All electrical components, including the linear actuator shall have the following warranty period:
 - Year 1-2: 100% Coverage
 - Year 3: 60% Coverage (Customer is responsible for 40% of replacement cost)
 - Year 4: 50% Coverage (Customer is responsible for 50% of replacement cost)
 - Year 5: 40% Coverage (Customer is responsible for 60% of replacement cost)
- Hydraulic actuators and mesh slings shall have a warranty period of one (1) year from the date of original purchase.
- Powder coat finish scratches, scrapes, corrosion, or dents from customers normal use, negligence, or abuse

This warranty specifically excludes reimbursement for labor to remove, repair, or install the product and any return freight charges. These warranties do not cover any damages due to accident, misuse, abuse, negligence or failure to properly maintain any products, or normal wear and tear from day to day operations. In the event that any products are altered, repaired, or improperly installed or improperly used by anyone without the prior written approval by Aqua Creek, all warranties are void. **IMPORTANT: AMOUNT OF WEIGHT PLACED ON LIFT SHALL NOT EXCEED THE RATED LIFTING CAPACITY FOR THE LIFT. NEVER OPERATE THE LIFT UNDER LOAD IN A DRY POOL (WITH NO WATER IN THE POOL).** It is the responsibility of the lift owner to verify the weight of the patron for warranty claim purposes and to ensure that the lift is not overloaded. Non-payment for product to Aqua Creek may void warranty.

To initiate a warranty claim, the owner of an Aqua Creek product must provide the place of purchase, in writing, with a full description of the product, its serial number, the dates of purchase and installation, and the exact nature of the defect. Within thirty (30) days after receipt of a written warranty claim by Aqua Creek, and barring any unforeseen delays, the place of purchase will be notified of Aqua Creek's decision regarding the claim.

If requested by Aqua Creek, any defective product must be returned, freight prepaid, to Aqua Creek's designated factory location or duly appointed distributor for inspection and/or repair. Aqua Creek will, at its option, repair or replace the failed or defective item, and deliver the repaired product or replacement to the buyer of the product, freight prepaid to the destination provided for in the original order. Products returned to Aqua Creek for which Aqua Creek provides replacement under this limited warranty shall become the property of Aqua Creek. A new warranty period shall NOT be established for the repaired or replaced products. Such products shall remain under warranty only for the remainder of the original warranty period on the original products purchased.

This written limited warranty constitutes the final, complete and exclusive statement of warranty terms. No person or organization is authorized to make any other specific or implied warranties or representations on behalf of Aqua Creek.

THE WARRANTIES SET FORTH HEREIN ARE IN LIEU OF ALL OTHER WARRANTIES, EXPRESSED OR IMPLIED, WHICH ARE HEREBY DISCLAIMED AND EXCLUDED, INCLUDING WITHOUT LIMITATION ANY WARRANTY OF MERCHANTABILITY OR FITNESS FOR A PARTICULAR PURPOSE OR USE.

THE SOLE AND EXCLUSIVE REMEDIES FOR BREACH OF ANY AND ALL WARRANTIES WITH RESPECT TO THE PRODUCTS SHALL BE LIMITED TO REPAIR OR REPLACEMENT AT AQUA CREEK'S DESIGNATED FACTORY LOCATION, OR DULY APPOINTED DISTRIBUTOR, OR IN PLACE AT AQUA CREEK'S OPTION. IN NO EVENT SHALL AQUA CREEK'S LIABILITY EXCEED THE ENTIRE AMOUNT PAID TO AQUA CREEK BY THE ORIGINAL PURCHASER FOR THE FAILED OR DEFECTIVE PRODUCT.

IN NO EVENT SHALL AQUA CREEK PRODUCTS, LLC BE LIABLE FOR ANY INCIDENTAL, CONSEQUENTIAL, SPECIAL, INDIRECT, PUNITIVE OR EXEMPLARY DAMAGES OR LOST PROFITS FROM ANY BREACH OF THIS LIMITED WARRANTY OR OTHERWISE.

THIS WARRANTY GIVES YOU SPECIFIC LEGAL RIGHTS AND YOU MAY ALSO HAVE OTHER RIGHTS, WHICH MAY VARY FROM STATE TO STATE. SOME STATES DO NOT ALLOW THE EXCLUSION OR LIMITATION OF INCIDENTAL, SPECIAL OR CONSEQUENTIAL DAMAGES, SO SOME OF THE ABOVE LIMITATIONS OR EXCLUSIONS MAY NOT APPLY TO YOU.

Aqua Creek Products, LLC

9889 Garrymore Lane

Missoula, MT 59808

Toll Free: (888) 687-3552

Local/Intl: (406) 549-0769

www.aquacreek.com