

CHLORINE FEEDER ENGINEERED FOR VARIABLE SPEED PUMPS

CMP# 25280-15X-000, 25280-16X, 25280-17X, 25280-45X, 25280-46X

READ ALL INFORMATION BEFORE PROCEEDING WITH ANY INSTALLATION. THE INFORMATION WILL HELP YOU INSTALL YOUR FEEDER PROPERLY AND AVOID PROBLEMS.

The Powerclean Ultra VS feeder comes with the Powerclean VS Low Flow Inlet, Cone and Outlet pre-installed. These are for systems with 2-speed or variable speed pumps where the system flow is less than 50 gpm at the lower speed. If the system uses only a single speed pump, or the low speed is over 50 gpm, remove the inserts.

INSTALLATION GUIDELINES

- Make sure all pumps and timer switches are OFF. The feeder is designed for permanent installation in the return line of the pool or spa and must always be installed after the heater, pool cleaner, valves, filter and all other equipment. Feeder should be installed above the water level. **IMPORTANT:** Heaters and other equipment may be damaged by highly chlorinated water.
- If the pool/spa is plumbed with 2" PVC pipe make sure the pump, heater and filter all have 2" inlet and outlet fittings. Glue 2" PVC pipe into feeder inlet and outlet. When using 1.5" PVC pipe, follow instructions above but glue into 1.5" unions
- When plumbing a pool/spa combo where the plumbing and equipment is 2" PVC and the feeder is installed on the pool return line *after* the diverter valve with a portion of the water going to the spa, install a minimum section of 6" x 1.5" PVC pipe directly into the inlet side of the feeder using the 1.5" unions. Continue with 2" PVC pipe on the outlet side of the feeder. This will compensate for the water being diverted.
- When plumbing 90 degree elbows directly into the feeder inlet it may cause turbulence inside the elbow which prevents water from entering the feeder. A minimum of 6" PVC pipe should be installed between the elbow and the inlet of the feeder.
- The arrows on feeder inlet and outlets should point in the direction of the water flow *returning* to the pool/spa.
- Use only PVC cement. Follow the directions on the cement label. Allow time for the PVC cement to completely dry.

OPERATING INSTRUCTIONS

Fill the feeder with water making sure to bleed out any entrapped air in any of the lines. To ensure maximum effectiveness, before starting the feeder the pool should be properly conditioned and the residual should be 1.0 to 1.5 ppm. Consult your local dealer for water conditioning information in your area.

1. Remove cap of feeder and fill with proper size tablets. For pools use 1" or 3" diameter tablets. For spas use 1" tablets.
2. If more chemical and a faster dissolve rate is desired, install the included chemical feeder tube at this time. The elbow of the feeder tube will fit into the outlet hole near the inside bottom of unit. If less chemical is desired, remove the chemical feeder tube.
3. Completely fill the chlorinator with water. Replace cap making sure o-ring is clean, lubricated and in place.
4. Turn on pump and timer switches for a minimum of 6 to 8 hours. The water level inside chlorinator will be 3 – 5 inches under normal running conditions.
5. Adjust the control valve clockwise for more chemical or counter clockwise for less chemical according to the size of the pool/spa. Use a test kit to determine the chemical residual. Check the chemical residual be checked daily for the first five days. **NOTE:** Hot weather, high water temperature and increased use will cause the pool/spa to use more chemical. Increase the feed rate a few days in advance when possible. The valve settings may require adjustment depending on the conditions.

RECHARGING THE FEEDER

1. Turn control valve to the closed position (counter clockwise). SHUT OFF PUMP.
2. Wait one minute allowing the water and fumes to drain from the feeder.
3. Leave the control valve closed and turn on the pump. (The check valve will prevent water from entering the feeder).
4. Remove cap and fill with tablets.
5. Replace cap making sure o-ring is clean, lubricated, and in place. (Hand tighten only).
6. Open control valve (clockwise) to original setting.

WINTERIZING THE FEEDER

This chlorinator has a drain plug located on the bottom for easy draining of the unit for winter. Follow other normal procedures for your system to winterize.

SPECIAL INSTRUCTIONS:

1. If the feeder does not provide enough chemical residual when using 3" tablets, switch to 1" tablets for faster erosion and increased residual.
2. If the glass lid becomes cloudy, turn off the feeder using the shut off instructions above (RECHARGING FEEDER). Remove the lid and wipe clean. If it remains cloudy, it will clear itself if left exposed to sunlight and fresh air. **DO NOT** leave chlorinator open without the lid installed. If the lid must be left off to clear up, a replacement must be installed temporarily
3. The bottom grate (#1 in diagram on page 2) is designed to be removed easily when chlorine is gummed up inside the unit. The chlorine residue must be dislodged or it may effect feeder performance. The grate helps keep pieces of the tablets from clogging the outlet. Be sure to check its position after each recharging as the grate may come out of its resting place when tablets are added to the chlorinator.



This feeder is designed to use only Trichlor-s-triazinetrione OR Bromine tablets- slow dissolving type. UNDER NO CIRCUMSTANCES MIX Trichlor or Bromine with Calcium Hydrochlorite, with other forms of concentrated chlorine or with other chemicals. FIRE AND/OR EXPLOSION MAY RESULT. NEVER use oil or grease to lubricate o-ring. Oil in contact with Trichlor OR Bromine may result in FIRE. Lubricate o-ring with approved silicone o-ring lubricant only. If you are not the original owner of this feeder, or not sure which chemical was used, be SAFE and flush thoroughly with fresh water. CAUTION SHOULD BE USED WHEN REMOVING CAP. DO NOT INHALE FUMES. IF YOUR POOL OR SPA HAS COPPER PLUMBING DO NOT INSTALL. This will damage the feeder. NOTE: If heaters are used, a Fireman's Switch or equivalent must be installed to prevent possible damage and improper operation of check valve and other equipment subject to heat damage.

REPLACEMENT PARTS DIAGRAM

	CMP P/N	DESCRIPTION
1	25280-100-005	GRATE
2	25280-000-920	CHECK VALVE ASSY
3	21023-000-000	2" UNION
4	25280-100-955	FLOW INDICATOR ASSY
5	25280-000-910	NUT
6	26100-100-330	O-RING, DIAL
7	25280-100-001	COVER NUT
7-8	25280-109-200	CLEAR GLASS COVER ASSY
7-8	25280-100-200	WHITE COVER ASSY
7-8	25280-100-002	CLEAR PLASTIC COVER ASSY
9	26101-060-530	O-RING, COVER
10	21023-030-000	UNION GASKET
11	25376-900-500	DRAIN PLUG W/ O-RING
12-14	25280-100-100	VS INSERT KIT

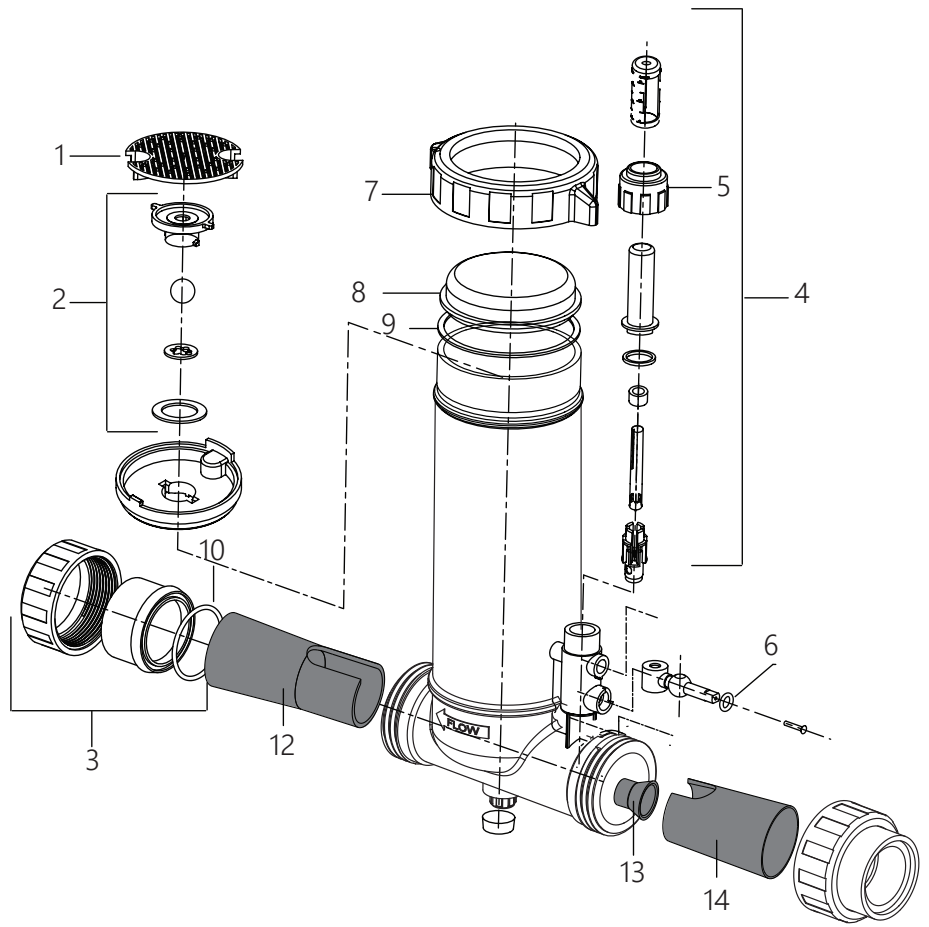

POWERCLEAN ULTRA VS PERFORMANCE CHART

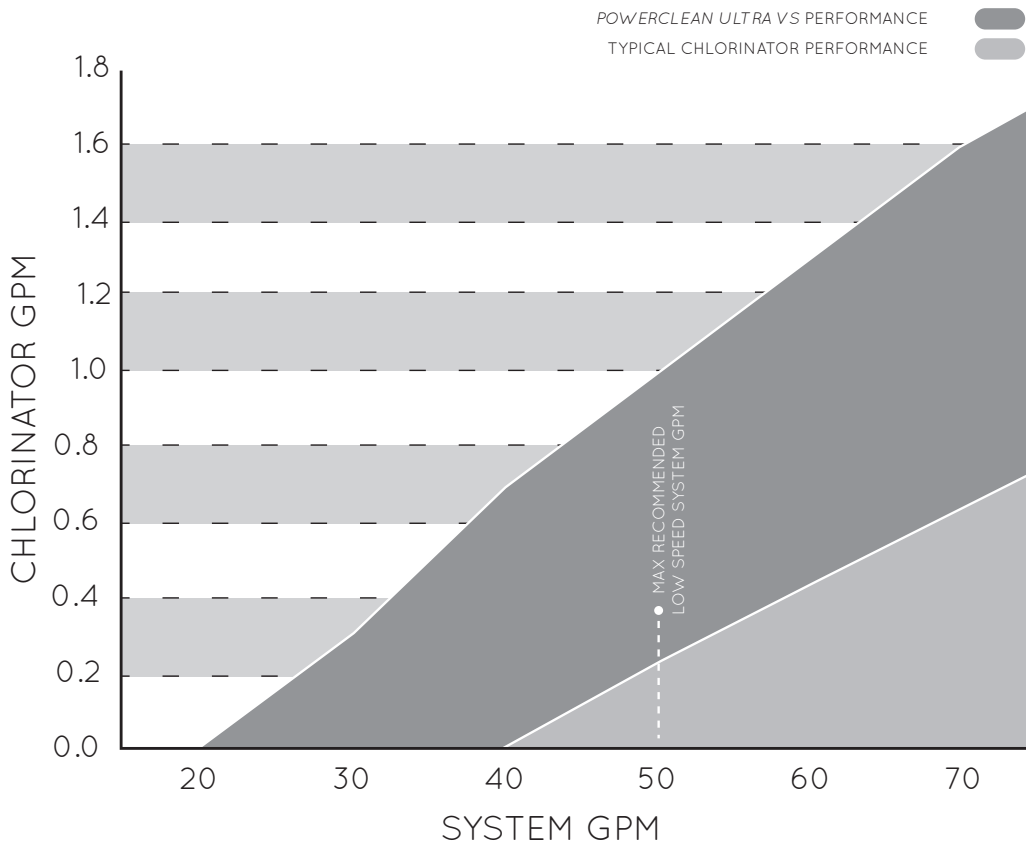

WARNING

Use only Trichlor-s-triazinetrione OR Bromine tablets - slow dissolving type.

UNDER NO CIRCUMSTANCES MIX Trichlor or Bromine with Calcium Hydrochlorite, with other forms of concentrated chlorine or with other chemicals. FIRE AND/OR EXPLOSION MAY RESULT.

NEVER use oils or grease to lubricate o-ring. Oil in contact with Trichlor OR Bromine may result in FIRE.