

# 48/56 Frame Power Defender Executive, EX2, & Viper Pump Instructions

**IMPORTANT SAFETY INSTRUCTIONS & WARNINGS • SAVE THESE INSTRUCTIONS • PLEASE READ AND FOLLOW ALL INSTRUCTIONS**

## **ALL ELECTRICAL INSTALLATIONS SHOULD BE PERFORMED BY QUALIFIED ELECTRICIANS**

- **2-SPEED MODELS: DO NOT wire both speeds to run simultaneously.** If supply cord is damaged, replace only with original replacement equipment available from authorized dealer.
- The pump is to be supplied through a residual current device (RCD) with a rated residual operating current not exceeding 30mA.
- Potential risk of fire, electrical shock, or injury to persons if misused.
- **DO NOT** install within an outer enclosure or beneath the skirt of the spa unless so marked.
- **WARNING:** To reduce the risk of injury, do not permit children to use this product unless they are closely supervised at all times.
- **CAUTION:** This pump is for use with permanently installed pools and may also be used with hot tubs and spas if so marked. **Do not use with storable pools.** A permanently installed pool is constructed in or on the ground or in a building such that it cannot be readily disassembled for storage. A storable pool is constructed so that it may be readily disassembled for storage and reassembled to its original integrity.

## **PUMP CONNECTIONS INSTALLATION INSTRUCTIONS**

**LOCATION:** Place pump on level surface. Pump must be installed below water surface. Shut off valves should be installed on both the inlet and outlet of the pump for future maintenance. Installation area should be clear of any direct water and have adequate floor drainage. Pump should be protected from excessive moisture.

The inlet and outlet have Waterway male union threads. Use Waterway tailpiece assemblies for best connection. These unions allow the pump to be removed for service without disturbing the plumbing. **HAND TIGHTEN UNIONS ONLY!**

**DO NOT** use pipe dope. Use only Teflon tape or other sealing compounds approved for use with plastic. Some pipe dopes not approved for use with plastic will cause stress cracking of plastic parts. New installations often require a plumbing inspection. This inspection is usually conducted using city water pressure. A pressure regulator should be used when performing this test and should not exceed 40 PSI during the pressure test. The filter and pump are under pressure. Insure that all air is removed during the pressure test. **FAILURE TO FOLLOW THESE INSTRUCTIONS EXPLICITLY CAN RESULT IN PERSONAL INJURY.**



2200 East Sturgis Road, Oxnard CA 93030 • Phone 805.981.0262 • Fax 805.981.9403  
www.waterwayplastics.com • waterway@waterwayplastics.com

## **MOTOR WIRING**

1. Before working on any electrical connections be sure that the power is turned off.
2. All wiring must conform to local, state and/or national codes.
3. All wiring must conform to wiring diagram on the motor nameplate or on the back of the terminal cover.
4. Applied voltage must correspond to the rated voltage as indicated on the marking plate.
5. **FOR SAFETY CLASS 1 EQUIPMENT:** It is mandatory to connect the pump to the protective conductor (grounding connector) of the earth-grounded main power supply.  
**FOR EQUIPOTENTIAL BONDING:** It is also possible in addition to use the external terminal on the body to realize an equipotential bonding with other earthed metallic parts.
6. **DO NOT ground to a gas supply line.**
7. Ground motor prior to connecting electrical power.
8. For disconnection from the supply, a circuit breaker having a contact separation of at least 3mm in all poles must be incorporated in the fixed wiring according to the wiring rules. Cord and plug provided with pump is intended to be used with mating spa pack connector.
9. Improper grounding can cause serious injury and damage to the motor, voiding the warranty.
10. If the supply cord is damaged, it must be replaced by a special cord or assembly available from the manufacturer or its service agent.

**For Wiring Instructions  
Refer to Wiring Diagram on Motor.**

Ensure wiring circuit agrees with diagram and leads are securely tight.

## **WARRANTY**

**For product registration visit: [www.waterwayplastics.com](http://www.waterwayplastics.com).  
For Warranty questions or claims please contact point of purchase.**

# TROUBLESHOOTING

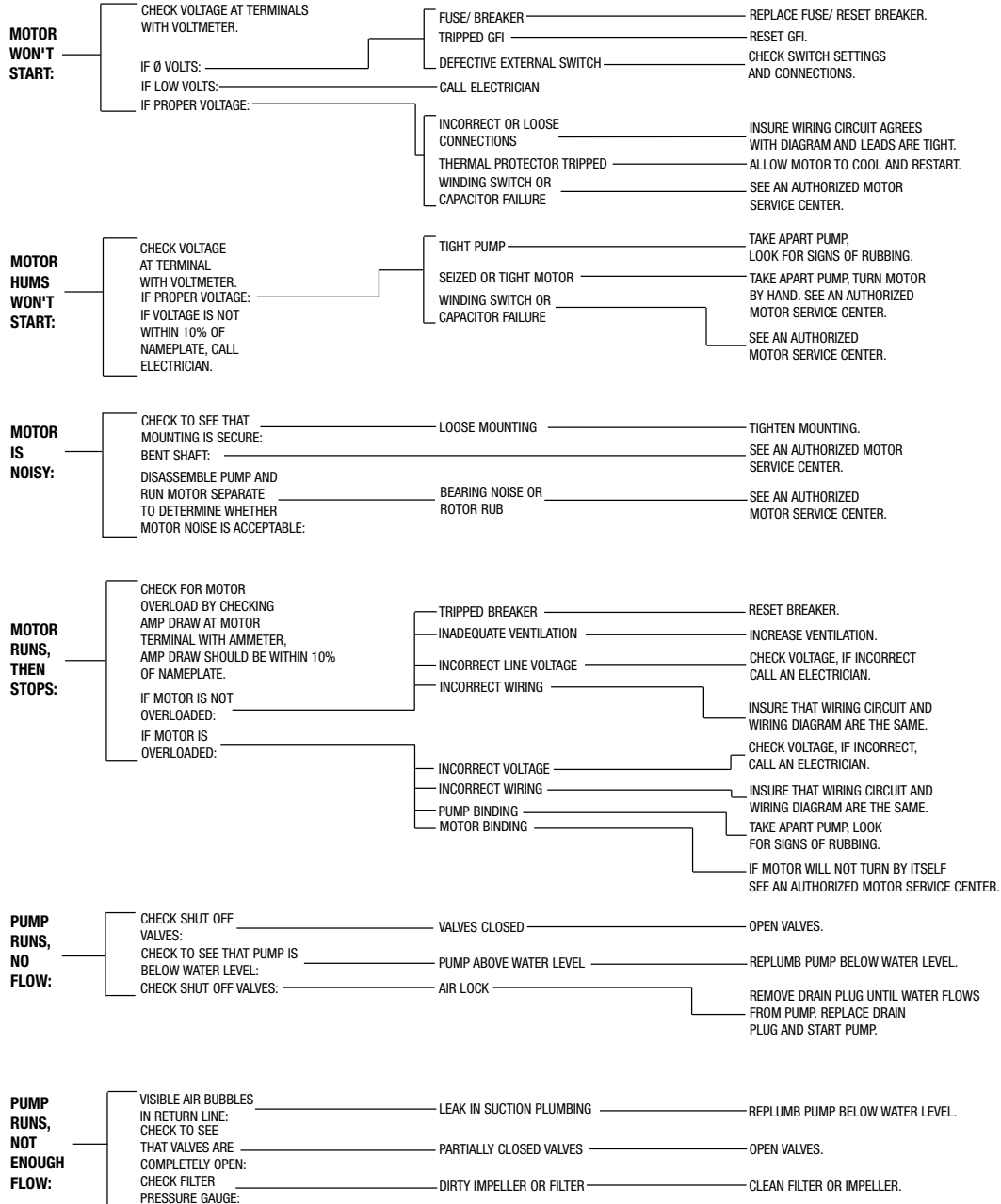

# ASSEMBLY DRAWING

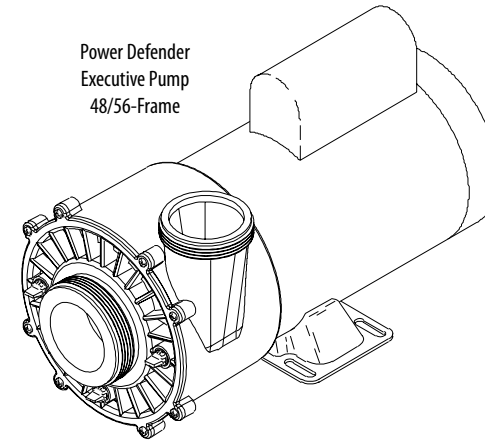

# EXPLODED VIEW

