

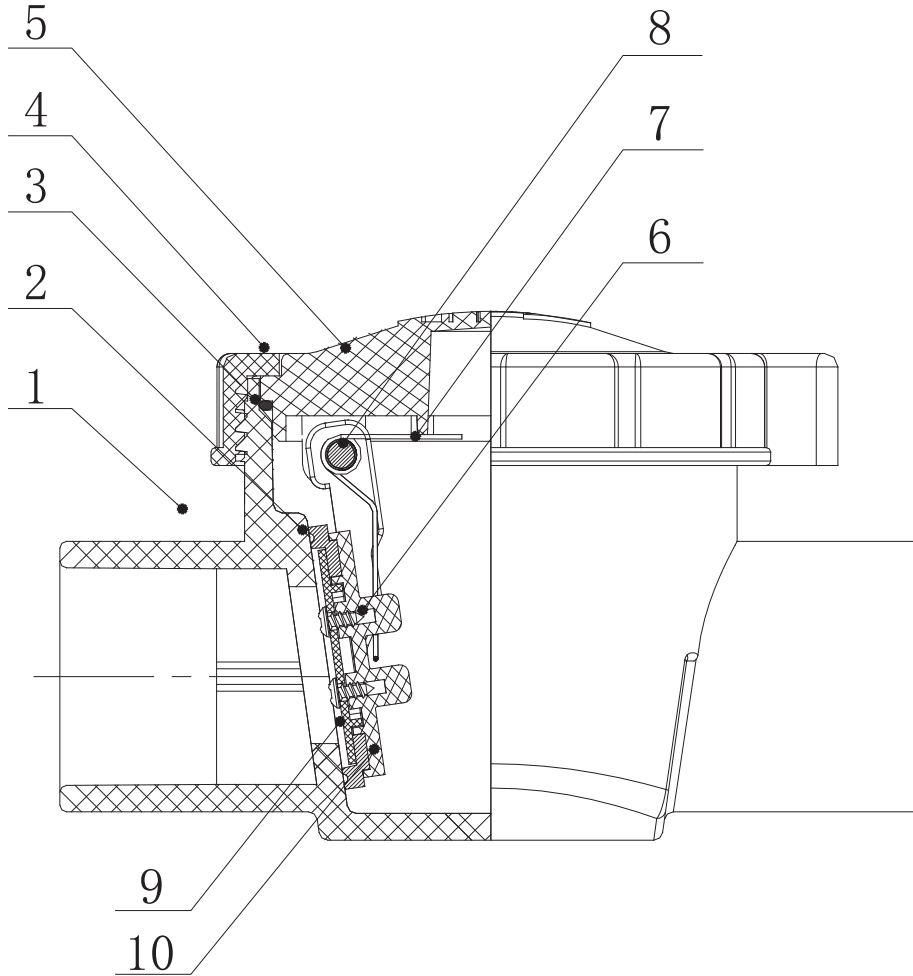

CUSTOM MOLDED PRODUCTS SERVICEABLE CHECK VALVES CMP#25830



- 1 - Valve housing
- 2 - Seal
- 3 - O-Ring
- 4 - Nut
- 5 - Cover
- 6 - Screw
- 7 - Spring
- 8 - Pin
- 9 - Flapper (Front)
- 10 - Flapper (Back)

Maintenance:

Inspect the function of the check valve by looking through the clear cover. The valve may be taken apart as needed so the o-ring, seal, and body can be checked for damage. Use a silicone lubricant to grease the o-ring before reinstalling.

Valve Location:

Locate the check valve at the lowest possible elevation for optimum performance. The weight of the water will help to seal the check valve. A minimum of an 18" water column is recommended.
