

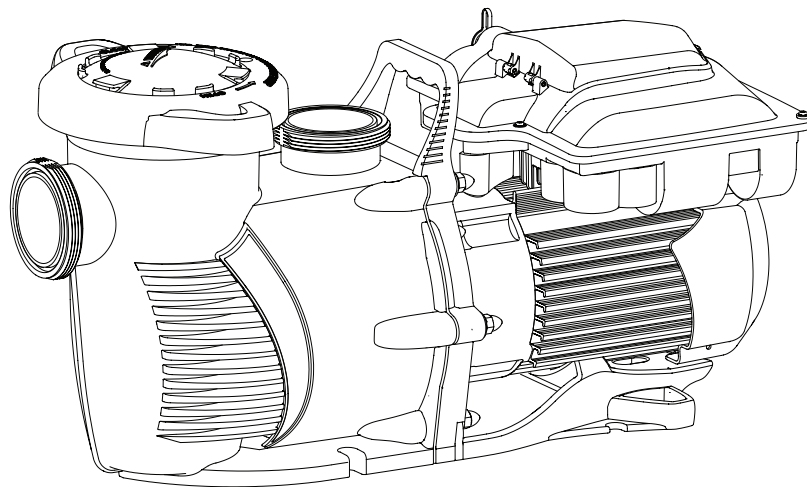

# WHISPERFLOXF<sup>®</sup> VS AND MAX-E-PROXF<sup>®</sup> VS COMMERCIAL VARIABLE SPEED PUMP



## INSTALLATION AND USER'S GUIDE

IMPORTANT SAFETY INSTRUCTIONS  
*READ AND FOLLOW ALL INSTRUCTIONS*  
SAVE THESE INSTRUCTIONS

## CUSTOMER SERVICE / TECHNICAL SUPPORT

If you have questions about ordering Pentair replacement parts, and pool products, please contact:

**Customer Service and Technical Support, USA**  
(8 A.M. to 4:30 P.M. — Eastern/Pacific Times)  
Phone: (800) 831-7133  
Fax: (800) 284-4151

### Web site

Visit [www.pentair.com](http://www.pentair.com) for information about our products.

**Sanford, North Carolina** (8 A.M. to 4:30 P.M. ET)  
Phone: (919) 566-8000  
Fax: (919) 566-8920

**Moorpark, California** (8 A.M. to 4:30 P.M. PT)  
Phone: (805) 553-5000 (Ext. 5591)  
Fax: (805) 553-5515

## TABLE OF CONTENTS

<b>Important Pump Warning and Safety Instructions</b> .....	<b>ii</b>	<b>Maintenance</b> .....	<b>15</b>
<b>Pump Overview</b> .....	<b>1</b>	Cleaning the Pump Strainer Basket	15
Drive Assembly and Control Panel	1	Winterizing	15
Motor Features	1	<b>Servicing</b> .....	<b>16</b>
Drive Features	1	Motor and Drive Care	16
<b>Installation</b> .....	<b>2</b>	Mechanical Seal	16
Location	2	Pump Disassembly	16
Piping	2	Pump Reassembly/Seal Replacement	17
Fittings and Valves	2	Removing and Replacing the Drive Assembly	18
Electrical Requirements	2	<b>Troubleshooting</b> .....	<b>19</b>
Electrical Installation	3	Problems and Corrective Actions	19
Wiring, Grounding and Bonding	3	Faults and Alarms	21
<b>Operation</b> .....	<b>4</b>	<b>Replacement Parts</b> .....	<b>22</b>
Using the Control Panel Keypad	4	Replacement Parts List	22
Setting the Clock	5	<b>Technical Data</b> .....	<b>23</b>
Factory Default Schedule	5	Performance Curves	23
Programming Custom Schedules	5	Pump Dimensions	23
Program Priorities	6	Electrical Specifications	23
Priming the Pump	7	Mechanical Specifications	23
Priming Adjustment	8		
Operating the Pump While Running	9		
Quick Clean	10		
Keypad Lockout	10		
Factory Reset	11		
<b>External Controls or Digital Inputs</b> .....	<b>12</b>		
Control with External Control and Digital Inputs	12		
Connecting to External Control	12		
External Control Only Mode	13		
Operating the Pump in Flow Mode	13		
Flow Mode Setup and Configuration	13		
Adjusting Flow Setting	14		

\* Translated versions of this manual are available online at / La versión en español de este manual del producto, se puede encontrar en línea a / La version française de ce manuel est disponible à :

<https://www.pentair.com/content/pentair/en/products/pool-spa-equipment/pool-pumps/whisperflox-variable-speed-pump.html>  
<https://www.pentair.com/content/pentair/en/products/pool-spa-equipment/pool-pumps/max-e-proxf-variable-speed-pump.html>

# IMPORTANT PUMP WARNING AND SAFETY INSTRUCTIONS



## IMPORTANT NOTICE

This guide provides installation and operation instructions for this product. Consult Pentair with any questions regarding this equipment.

**Attention Installer:** This guide contains important information about the installation, operation and safe use of this product. This information should be given to the owner and/or operator of this equipment after installation or left on or near the pump.

**Attention User:** This manual contains important information that will help you in operating and maintaining this product. Please retain it for future reference.

## READ AND FOLLOW ALL INSTRUCTIONS SAVE THESE INSTRUCTIONS



This is the safety alert symbol. When you see this symbol on your system or in this manual, look for one of the following signal words and be alert to the potential for personal injury.

**⚠ DANGER**

Warns about hazards that can cause death, serious personal injury, or major property damage if ignored.

**⚠ WARNING**

Warns about hazards that may cause death, serious personal injury, or major property damage if ignored.

**⚠ CAUTION**

Warns about hazards that may or can cause minor personal injury or property damage if ignored.

### NOTE

Indicates special instructions not related to hazards.

Carefully read and follow all safety instructions in this manual and on equipment. Keep safety labels in good condition; replace if missing or damaged.

When installing and using this electrical equipment, basic safety precautions should always be followed, include the following:

**⚠ WARNING**

Do not permit children to use this product.

**⚠ WARNING**

**RISK OF ELECTRICAL SHOCK** (For all permanently installed units intended for use on 15 or 20 ampere, 125 through 240 volt, single phase branch circuits). Connect only to a branch circuit protected by a ground-fault circuit-interrupter (GFCI). Contact a qualified electrician if you cannot verify that the circuit is protected by a GFCI. This unit must be connected only to a supply circuit that is protected by a ground-fault circuit-interrupter (GFCI). Such a GFCI should be provided by the installer and should be tested on a routine basis. To test the GFCI, push the test button. The GFCI should interrupt power. Push the reset button. Power should be restored. If the GFCI fails to operate in this manner, the GFCI is defective. If the GFCI interrupts power to the pump without the test button being pushed, a ground current is flowing, indicating the possibility of an electric shock. Do not use this pump. Disconnect the pump and have the problem corrected by a qualified service representative before using.

**⚠ CAUTION**

This pump is for use with permanent swimming pools and may also be used with hot tubs and spas if so marked. Do not use with storable pools. A permanently-installed pool is constructed in or on the ground or in a building such that it cannot be readily disassembled for storage. A storable pool is constructed so that it is capable of being readily disassembled for storage and reassembled to its original integrity.

## General Warnings

- Never open the inside of the drive motor enclosure. There is a capacitor bank that holds a 230 VAC charge even when there is no power to the unit.
- The pump is not submersible.
- The pump is capable of high flow rates; use caution when installing and programming to limit pumps performance potential with old or questionable equipment.
- Code requirements for electrical connection differ from country to country, state to state, as well as local municipalities. Install equipment in accordance with the National Electrical Code and all applicable local codes and ordinances.
- Before servicing the pump; switch OFF power to the pump by disconnecting the main circuit to the pump.
- This appliance is not intended for use by persons (including children) of reduced physical, sensory or mental capabilities, or lack of experience and knowledge, unless they have been given supervision or instruction concerning the use of the appliance by a person responsible for their safety.

**⚠ DANGER** FAILURE TO FOLLOW ALL INSTRUCTIONS AND WARNINGS CAN RESULT IN SERIOUS BODILY INJURY OR DEATH. **THIS PUMP SHOULD BE INSTALLED AND SERVICED ONLY BY A QUALIFIED POOL SERVICE PROFESSIONAL. INSTALLERS, POOL OPERATORS AND OWNERS MUST READ THESE WARNINGS AND ALL INSTRUCTIONS IN THE OWNER'S MANUAL BEFORE USING THIS PUMP. THESE WARNINGS AND THE OWNER'S MANUAL MUST BE LEFT WITH THE POOL OWNER.**

**⚠ DANGER** SUCTION ENTRAPMENT HAZARD: STAY OFF THE MAIN DRAIN AND AWAY FROM ALL SUCTION OUTLETS!



THIS PUMP PRODUCES HIGH LEVELS OF SUCTION AND CREATES A STRONG VACUUM AT THE MAIN DRAIN AT THE BOTTOM OF THE BODY OF WATER. THIS SUCTION IS SO STRONG THAT IT CAN TRAP ADULTS OR CHILDREN UNDER WATER IF THEY COME IN CLOSE PROXIMITY TO A DRAIN OR A LOOSE OR BROKEN DRAIN COVER OR GRATE.

THE USE OF UNAPPROVED COVERS OR ALLOWING USE OF THE POOL OR SPA WHEN COVERS ARE MISSING, CRACKED OR BROKEN CAN RESULT IN BODY OR LIMB ENTRAPMENT, HAIR ENTANGLEMENT, BODY ENTRAPMENT, Evisceration AND/OR DEATH.

The suction at a drain or outlet can cause:

**Limb Entrapment:** When a limb is sucked or inserted into an opening resulting in a mechanical bind or swelling. This hazard is present when a drain cover is missing, broken, loose, cracked or not properly secured.

**Hair Entanglement:** When the hair tangles or knots in the drain cover, trapping the swimmer underwater. This hazard is present when the flow rating of the cover is too small for the pump or pumps.

**Body Entrapment:** When a portion of the body is held against the drain cover trapping the swimmer underwater. This hazard is present when the drain cover is missing, broken or the cover flow rating is not high enough for the pump or pumps.

**Evisceration/Disembowelment:** When a person sits on an open pool (particularly a child wading pool) or spa outlet and suction is applied directly to the intestines, causing severe intestinal damage. This hazard is present when the drain cover is missing, loose, cracked, or not properly secured.

# IMPORTANT PUMP WARNING AND SAFETY INSTRUCTIONS

**Mechanical Entrapment:** When jewelry, swimsuit, hair decorations, finger, toe or knuckle is caught in an opening of an outlet or drain cover. This hazard is present when the drain cover is missing, broken, loose, cracked, or not properly secured.

**NOTE: ALL SUCTION PLUMBING MUST BE INSTALLED IN ACCORDANCE WITH THE LATEST NATIONAL AND LOCAL CODES, STANDARDS AND GUIDELINES.**

**WARNING** TO MINIMIZE THE RISK OF INJURY DUE TO SUCTION ENTRAPMENT HAZARD:

- A properly installed and secured ANSI/ASME A112.19.8 approved anti-entrapment suction cover must be used for each drain.
- Each suction cover must be installed at least three (3') feet apart, as measured from the nearest point to nearest point.
- Regularly inspect all covers for cracks, damage and advanced weathering.
- If a cover becomes loose, cracked, damaged, broken or is missing, replace with an appropriate certified cover.
- Replace drain covers as necessary. Drain covers deteriorate over time due to exposure to sunlight and weather.
- Avoid getting hair, limbs or body in close proximity to any suction cover, pool drain or outlet.
- Disable suction outlets or reconfigure into return inlets.

**The Virginia Graeme Baker (VGB) Pool and Spa Safety Act** creates new requirements for owners and operators of commercial swimming pools and spas.

Commercial pools or spas constructed on or after December 19, 2008, shall utilize:

(A) A multiple main drain system without isolation capability with suction outlet covers that meet ASME/ANSI A112.19.8a Suction Fittings for Use in Swimming Pools, Wading Pools, Spas, and Hot Tubs and either:

- (i) A safety vacuum release system (SVRS) meeting ASME/ANSI A112.19.17 Manufactured Safety Vacuum Release systems (SVRS) for Residential and Commercial Swimming Pool, Spa, Hot Tub, and Wading Pool Suction Systems and/or ASTM F2387 Standard Specification for Manufactured Safety Vacuum Release Systems (SVRS) for Swimming pools, Spas and Hot Tubs or
- (ii) A properly designed and tested suction-limiting vent system or
- (iii) An automatic pump shut-off system.

Commercial pools and spas constructed prior to December 19, 2008, with a single submerged suction outlet shall use a suction outlet cover that meets ASME/ANSI A112.19.8a and either:

- (A) A SVRS meeting ASME/ANSI A112.19.17 and/or ASTM F2387, or
- (B) A properly designed and tested suction-limiting vent system, or
- (C) An automatic pump shut-off system, or
- (D) Disabled submerged outlets, or
- (E) Suction outlets shall be reconfigured into return inlets.

**For Installation of Electrical Controls at Equipment Pad (ON/OFF Switches, Timers and Automation Load Center)**

**CAUTION**



Install all electrical controls at equipment pad, such as on/off switches, timers, and control systems, etc. to allow the operation (startup, shut-down, or servicing) of any pump or filter so the user does not place any portion of his/her body over or near the pump strainer lid, filter lid or valve closures. This installation should

allow the user enough space to stand clear of the filter and pump during system start-up, shut down or servicing of the system filter.

**WARNING**

A clearly labeled emergency shut-off switch for the pump must be in an easily accessible, obvious place.

Make sure users know where it is and how to use it in case of emergency.

**DANGER**



**HAZARDOUS PRESSURE: STAND CLEAR OF PUMP AND FILTER DURING START UP**

Circulation systems operate under high pressure. When any part of the circulating system (i.e. locking ring, pump, filter, valves, etc.) is serviced, air can enter the system and become pressurized. Pressurized air can cause the pump housing cover

filter lid and valves to violently separate which can result in severe personal injury or death. Filter tank lid and strainer cover must be properly secured to prevent violent separation. Stand clear of all circulation system equipment when turning on or starting up pump.

Before servicing equipment, make note of the filter pressure. Be sure that all controls are set to ensure the system cannot inadvertently start during service. Turn off all power to the pump. **IMPORTANT: Place filter manual air relief valve in the open position and wait for all pressure in the system to be relieved.**

Before starting the system, fully open the manual air relief valve and place all system valves in the "open" position to allow water to flow freely from the tank and back to the tank. Stand clear of all equipment and start the pump.

**IMPORTANT: Do not close filter manual air relief valve until all pressure has been discharged from the valve and a steady stream of water appears.** Observe filter pressure gauge and be sure it is not higher than the pre-service condition.

## General Installation Information

- All work must be performed by a qualified service professional, and must conform to all national, state, and local codes.
- Install to provide drainage of compartment for electrical components.
- These instructions contain information for a variety of pump models and therefore some instructions may not apply to a specific model. All models are intended for use in swimming pool applications. The pump will function correctly only if it is properly sized to the specific application and properly installed.

**WARNING**

Pumps improperly sized or installed or used in applications other than for which the pump was intended can result in severe personal injury or death. These risks may include but not be limited to electric shock, fire, flooding, suction entrapment or severe injury or property damage caused by a structural failure of the pump or other system component.

**WARNING**

The pump can produce high levels of suction within the suction side of the plumbing system. These high levels of suction can pose a risk if a person comes within the close proximity of the suction openings. A person can be seriously injured by this high level of vacuum or may become trapped and drown. It is absolutely critical that the suction plumbing be installed in accordance with the latest national and local codes for swimming pools.

Warnings and safety instructions for Pentair Water Pool and Spa, Inc. pumps and other related products are available at:

<http://www.pentairpool.com/pool-owner/safety-warnings/> or call (800) 831-7133 for additional free copies of these instructions.

Please refer to <http://www.pentairpool.com/pool-owner/safetywarnings/> for warning and safety instructions related to this product.

## SAVE THESE INSTRUCTIONS

# PUMP OVERVIEW

The WhisperFloXF® VS or Max-E-ProXF® VS Commercial Variable Speed Pump can be programmed to run at specific speeds and time intervals for maximum operating efficiency and energy conservation for a variety of inground pools.

- The pump can operate at any speed between 300 RPM to 3450 RPM for different applications, with four preset speeds of 1720, 2500, 3000 and 3450 (Quick Clean).
- Pump control panel alarm LED and error messages warn the user against under and over voltage, high temperature and over current.
- Communicates with most Pentair automation systems via digital input connection (External Control Wiring Kit, P/N 353129Z).
- Adjustable priming mode for easy start-up
- Compatible with most cleaning systems, filters, and jet action spas
- WEF [5.0](#) THP [5.0](#)

## Drive Assembly and Control Panel

The pump's drive is designed to produce maximum motor operational efficiency. The drive controls the motor's rotational speed by controlling the frequency of the supplied current. It also protects the motor and pump from operating outside of their intended operating parameters.

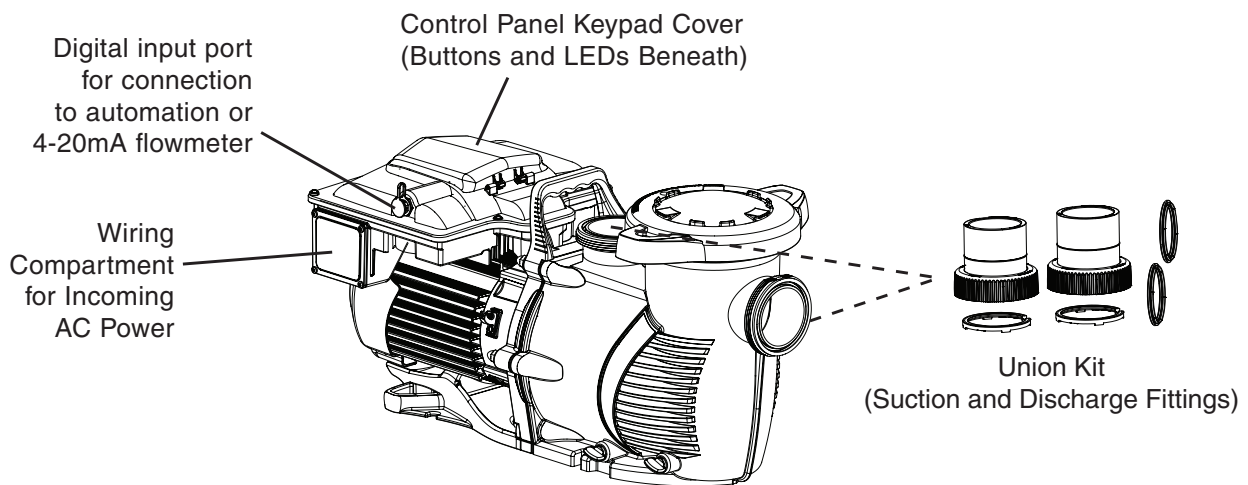

**Pump Overview**

## Motor Features

- Superior speed control for commercial applications
- Operates at lower temperatures due to high efficiency
- Designed to withstand outdoor environment
- Totally Enclosed Fan Cooled (TEFC) Motor
- 56 Square Flange
- Low noise

## Drive Features

- Active Power Factor Correction
- High Drive Operational Efficiency
- Flow Control Capable When Paired with a 4-20mA Flowmeter (Pentair P/N 97014-4203KIT).
- Versatile power input:
  - Single-Phase, 208-230/277-460V, 20-21/17-11A
  - 3-Phase, 208-460V, 13-6A



## INSTALLATION

Only a qualified plumbing professional should install the WhisperFloXF® VS and Max-E-ProXF® VS Commercial Variable Speed Pumps. Refer to “Important Pump Warning And Safety Instructions” on pages ii - iii for additional installation and safety information.

### Location

**Note:** Do not install this pump within an outer enclosure or beneath the skirt of a hot tub or spa unless marked accordingly.

**Note:** Ensure that the pump is mechanically secured to the equipment pad.

#### Be sure the pump location meets the following requirements:

1. Install the pump as close to the pool or spa as possible. To reduce friction loss and improve efficiency, use short, direct suction and return piping.
2. Install a minimum of 5 feet (1.52 meters) from the inside wall of the pool and spa. Canadian installations require a minimum of 9.8 feet (3 meters) from the inside wall of the pool.
3. Install the pump a minimum of 3 feet (.9 meters) from the heater outlet.
4. Do not install the pump more than 10 feet (3.1 meters) above the water level.
5. Install the pump in a well ventilated location protected from excess moisture (i.e. rain gutter downspouts, sprinklers, etc.).
6. Install the pump with a rear clearance of at least 3 inches (7.6 cm) so that the motor can be removed easily for maintenance and repair. **See Figure 1.**

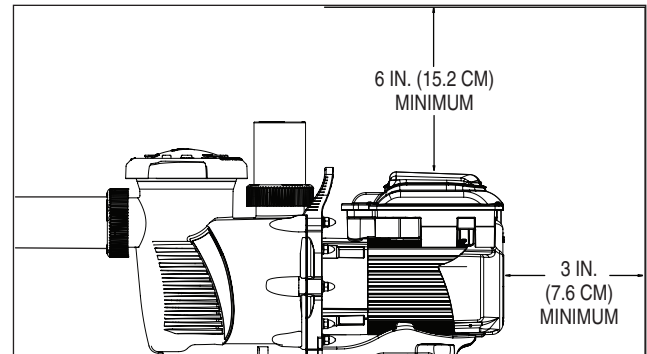

**Figure 1:** Pump Rear and Vertical Clearance

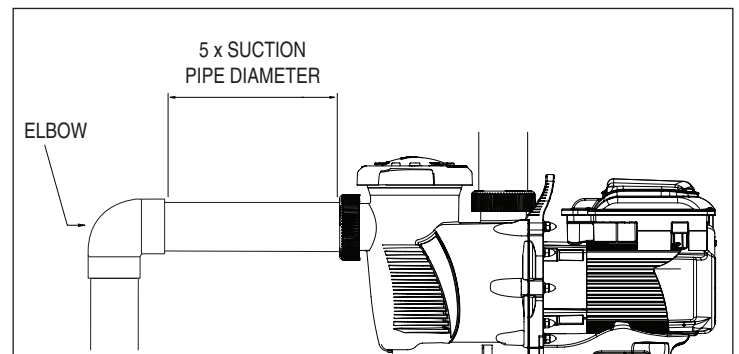

**Figure 2:** Recommended Piping

### Piping

1. For improved pool plumbing, it is recommended to use a larger pipe size.
2. Piping on the suction side of the pump should be the same or larger than the return line diameter.
3. Plumbing on the suction side of the pump should be as short as possible.
4. For most installations Pentair recommends installing a valve on both the pump suction and return lines so that the pump can be isolated during routine maintenance. However, we also recommend that a valve, elbow or tee installed in the suction line should be no closer to the front of the pump than five (5) times the suction line diameter. **See Figure 2.**

**Example:** A 2.5 inch pipe requires a 12.5 inch (31.8 cm) straight run in front of the suction inlet of the pump. This will help the pump prime faster and last longer.

**Note:** DO NOT install 90° elbows directly into the pump inlet or outlet.

### Fittings and Valves

1. Do not install 90° elbows directly into pump inlet.
2. Flooded suction systems should have gate valves installed on suction and discharge pipes for maintenance, however, the suction gate valve should be no closer than five times the suction pipe diameter as described in this section.
3. Use a check valve in the discharge line when using this pump for any application where there is significant height to the plumbing after the pump.
4. Be sure to install check valves when plumbing in parallel with another pump. This helps prevent reverse rotation of the impeller and motor.

### Electrical Requirements

- Install all equipment in accordance with the National Electrical code and all applicable local codes and ordinances.
- A means for disconnection must be incorporated in the fixed wiring in accordance with the wiring rules.

## Electrical Installation

### **WARNING**



**RISK OF ELECTRICAL SHOCK OR ELECTROCUTION.** This pump must be installed by a licensed or certified electrician or a qualified service professional in accordance with the National Electrical Code and all applicable local codes and ordinances. Improper installation will create an electrical hazard which could result in death or serious injury to users, installers, or others due to electrical shock, and may also cause damage to property.

**Always disconnect power to the pump at the circuit breaker before servicing the pump. Failure to do so could result in death or serious injury to service people, users or others due to electric shock.**

Read all servicing instructions before working on the pump.

**Note:** ALWAYS reinstall the cover onto the field wiring compartment when leaving the pump unsupervised during servicing. This will prevent foreign matter (i.e. rainwater, dust, etc.) from accumulating inside the compartment.

**Note:** When connecting the pump to an automation system, continuous power must be supplied to the pump by connecting it directly to the circuit breaker. When using an automation system, be sure that no other lights or appliances are on the same circuit.

### Wiring

1. Be sure all electrical breakers and switches are turned off before wiring motor.

### **WARNING**

**STORED CHARGE** - Wait at least sixty (60) seconds before servicing.

2. Be sure that the supply voltage meets the requirements listed on the motor nameplate. If these requirements are not met, permanent motor damage may occur.
3. For wiring sizes and general guidelines for proper electrical installation, please follow the specifications defined in the National Electric Code and any local codes as required.
4. Use a strain relief and be sure all electrical connections are clean and tight.
5. Cut the wires to the appropriate length so they do not overlap or touch when connected.
6. Wire the pump according to instructions given on the inside of the field wiring cover, then secure the field wiring cover with the four (4) corner screws.
7. DO NOT install motor starters on these pumps. These devices can cause low input voltage alarms.

### Grounding

1. Permanently ground the motor using the green ground screw (see **Figure 3**). Use the correct wire size and type specified by National Electrical Code. Be sure the ground wire is connected to an electrical service ground.
2. The pump should be permanently connected to either a circuit breaker, 2-pole timer or 2-pole relay.
 

**Note:** If AC power is supplied by a GFCI circuit breaker, the pump should be wired on its own independent circuit **unless the pump is operated in tandem with a Pentair salt chlorine generator.**
3. A surge jumper has been factory-installed between the two (2) bottom screw terminals in the wiring compartment. Ensure this surge jumper is in place before wiring the pump. See **Figure 3**.

### **WARNING**

This surge jumper grounds all drive components and will protect them from repeated voltage surges. If surge jumper is not installed damage to the pump drive may occur.

### Bonding

1. Bond the motor to the structure in accordance with the National Electrical Code. Use a solid copper bonding conductor not smaller than 8 AWG. For Canadian installations, a 6 AWG or larger solid copper bonding conductor is required. Run a wire from the external bonding screw or lug to the bonding structure.
2. Connect the wire from the accessible bonding lug on the motor to all metal parts of the swimming pool, spa, or hot tub structure and to all electrical equipment, metal conduit, and metal piping within 5 feet (1.52 meters) of the inside walls of the swimming pool, spa, or hot tub. Run a wire from the external bonding lug to the bonding structure. See **Figure 3**.

**Note:** When the pump is started and stopped by removing power with a relay or timer, a two-pole device should be used to apply and remove power to both POWER LINE TERMINALS.

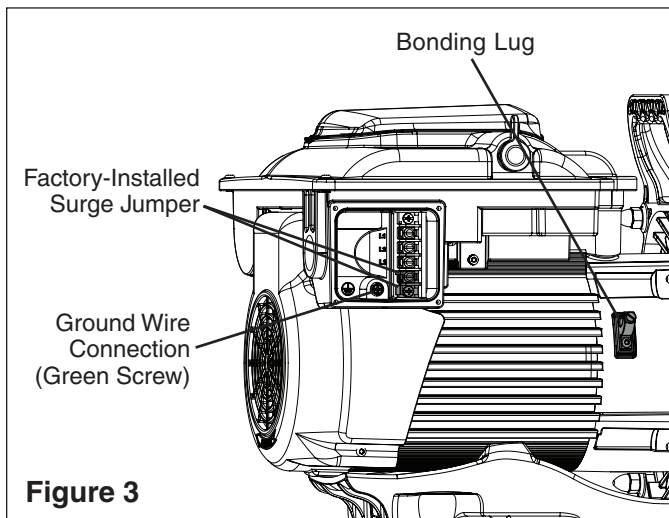

**Figure 3**

## OPERATION

Before operating the pump for the first time, the pump's internal clock and operational schedules must be programmed by following the steps in this manual. Please refer to "Setting the Clock" and "Custom Schedules", on page 5, for instructions regarding the programming of this pump for scheduled operation.

This pump is capable of maintaining either constant speeds or constant flows. The factory default drive settings is Speed Control. For information on configuring the pump for Flow Control via 4-20mA flowmeter, refer to *Operating the Pump in Flow Mode* on pages 13-14.

### Using the Control Panel Keypad

The WhisperFloXF® VS or Max-E-ProXF® VS Commercial Variable Speed Pump is programmed and controlled via the control panel keypad. Pump features and settings are also accessed using this keypad.

**Note:** Always close the keypad cover after use. This will prevent preventable damage to the keypad and other drive components.

#### CAUTION

Only press keypad buttons with your fingers. Using screwdrivers, pens or other tools to program the pump will damage the keypad.

#### WARNING

If power is connected to the pump motor, pressing any of the following buttons referred to in this section could result in the motor starting. Failure to recognize this could result in personal injury or damage to equipment.

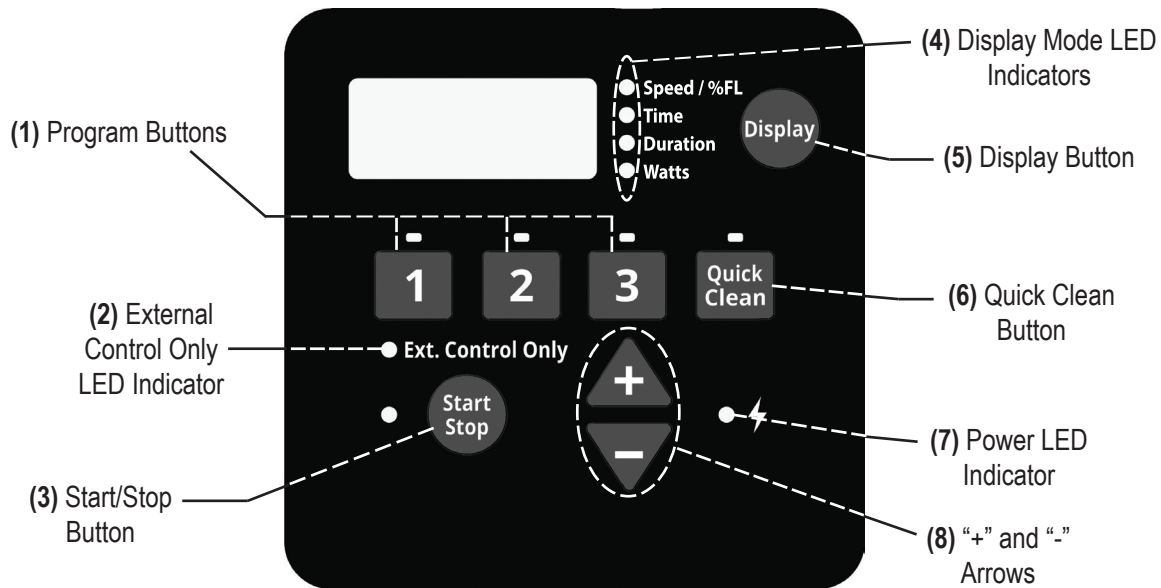

1. **Program Buttons** - Used to select the desired program. The LED above the Program Buttons will illuminate when that program is selected or is currently running. A flashing LED indicates that an External Control is active on that program's channel.
2. **External Control Only LED Indicator** - Indicates that the pump is operating in External Control mode. When LED is illuminated the schedule is disabled and the only input is from the low voltage external controls.
3. **Start/Stop Button** - Used to Start and Stop the pump. When the pump is stopped and the LED is not illuminated, the pump is unable to run from any type of input.
4. **Display Mode LED Indicators** - An illuminated LED indicates the information being displayed on the screen at any specific point. A flashing LED indicates that the parameter is currently being edited.
5. **Display Button** - Used to toggle between the different available display modes. This button is also used to set the 24-hour clock and screen resolution.
6. **Quick Clean Button** - Used to run a selected speed and duration programmed for Quick Clean. When the LED is illuminated a Quick Clean cycle is active.
7. **Power LED Indicator** - An illuminated LED indicates that there is live power being supplied to the pump.
8. **"+" and "-" Arrows** - Used to make on screen adjustments to the pump settings. The "+" arrow increases the value of a given setting, while "-" decreases the value of a given setting. Pressing and holding down either arrow button will increase or decrease the incremental changes faster.



## Setting the Clock

When the pump is first plugged in, the clock will blink to indicate that it has not been set. Any daily schedule set by the user will be based on this clock setting, so it will be necessary to set the clock first.

### To Set the Clock:

1. Hold the **Display** button for 3 seconds.
2. Use the “+” and “-” arrows to choose between a 12 or 24 hour time format.
3. Press **Display** to advance in the Clock Setup menu.
4. Use the “+” and “-” arrows to change the time to the correct time of day. In the 12 hour time format AM/PM will display in the bottom right corner.
5. Press **Display** to advance.
6. Use the “+” and “-” arrows to adjust the screen backlight brightness.
7. Press **Display** to exit the Clock Setup menu. The clock is now set.

During a power outage, the drive will retain the clock setting in memory for as long as 24 hours. If the power is out longer than 24 hours the clock will have to be set again. If the drive has lost the user set time, the clock will continuously blink until the time is reset. Once the time is reset the clock will stop blinking.

**Note:** When power is returned to the pump after a prolonged outage (24+ hours) the clock will automatically set itself to the PROGRAM 1 start time, blink and advance. The pump will also run the associated schedule from that start time.

## Factory Default Schedule

The default schedule is designed to provide enough daily turnover to service a typical pool. See **Table 1** for default schedule.

**Note:** The **Start/Stop** button must be pressed, and the LED lit, for the pump to run.

	Duration (Hours)	Speed (RPM)
<b>PROGRAM 1</b>	24	1720
<b>PROGRAM 2</b>	0	2500
<b>PROGRAM 3</b>	0	3000

**Table 1:** Default Schedule

## Programming Custom Schedules

To customize the run schedule for your WhisperFloXF® VS or Max-E-ProXF® VS Commercial Variable Speed Pump, the pump must be stopped. Be sure that the **Start/Stop** button LED is not illuminated.

### Programming a Custom Schedule:

**Note:** The clock must be set before programming a custom schedule.

**Note:** When programming, the LED light next to the parameter (“Spd / %FL”, “Time” and “Duration”) you are setting will blink.

1. Stop the pump if it is running by pressing the **Start/Stop** button.
2. Press the “1” button. The LED above the selected PROGRAM will begin to blink and the “Spd / %FL” parameter LED will blink while editing. See **Figure 4**.



**Figure 4:** Setting Speed

3. Use the “+” and “-” arrows to adjust the speed in RPM, or percentage of flow if operating in Flow Mode, for PROGRAM 1.

**Note:** Speed is adjusted up or down by increments of 10 RPM. Flow is adjusted in 5-percent increments.

4. Press the “1” button again and the display will change to PROGRAM 1 start time. The “Time” parameter LED will begin to blink. See **Figure 5**.



**Figure 5:** Setting Start Time

5. Use the “+” and “-” arrows to adjust the daily start time for PROGRAM 1.

- Continue to next page -

## Programming Custom Schedules (cont.)

6. Press the “1” button again and the display will change to PROGRAM 1 duration. The “Duration” parameter LED will begin to blink. See **Figure 6**.



**Figure 6:** Setting Duration

7. Use the “+” and “-” arrows to adjust the duration for PROGRAM 1 in hours and minutes.  
**Note:** The duration parameter is adjusted in 15 minute increments.
8. Pressing the “1” button will continue to cycle through these parameters, but the changes are immediately saved as they are adjusted.
9. Press the “2” button. The LED above PROGRAM 2 will begin to flash and the corresponding parameter LED will flash while editing.
10. Use the “+” and “-” arrows to adjust the speed in RPM, or percentage of flow if operating in Flow Mode, for PROGRAM 2.
11. Press the “2” button again and the display will change to PROGRAM 2 duration.  
**Note:** PROGRAMS 2 and 3 do not have a start time, as they begin their duration immediately after the previous PROGRAM finishes.
12. Use the “+” and “-” arrows to adjust the duration for PROGRAM 2 in hours and minutes.
13. Repeat steps 9-12 to program PROGRAM 3 and QUICK CLEAN.  
**Note:** Remember that the duration allowed for PROGRAM 3 will be limited to the remaining time in a 24 hour day. Any time in the 24 hour day not programmed into PROGRAMS 1-3, the pump will remain in a stationary state.  
 [ PROGRAM 1 + PROGRAM 2 + PROGRAM 3 ≤ 24 Hours ]

14. Press the **Start/Stop** button and ensure the LED is lit. The pump is now on and will run the custom user-programmed schedule.

**Note:** If the pump has been stopped via the **Start/Stop** button, the pump will not run until the pump is turned back on by the **Start/Stop** button. If the **Start/Stop** LED is illuminated then the pump is on and will run the programmed schedule.

**Note:** If a user wants to have a period of time during the day when the pump is not running, any of the PROGRAMS can be programmed to 0 RPM. This will cause the pump to remain stationary/paused throughout the duration of that PROGRAM.

## Program Priorities (Non-External Control)

For schedule duration settings, PROGRAMS are prioritized as follows: PROGRAM 1 -> PROGRAM 2 -> PROGRAM 3. PROGRAM 1 is the highest priority, while PROGRAM 3 is the lowest.

The drive will not allow a user to program a schedule of more than 24 hours. When the 24th hour of duration is programmed it will take time from the lower priority PROGRAMS in order to add them to the PROGRAM currently being adjusted.

### **Example:**

#### Starting Schedule (Before Adjustment)

PROGRAM 1 duration = 20 hours

PROGRAM 2 duration = 2 hours

PROGRAM 3 duration = 2 hours

If the user reprograms PROGRAM 1 to run for 23 hours, PROGRAM 2 (lower priority) will automatically adjust to a 1 hour duration and PROGRAM 3 (lowest priority) will adjust to a 0 hour duration.

#### End Schedule (After Adjustment)

PROGRAM 1 duration = 23 hours

PROGRAM 2 duration = 1 hour

PROGRAM 3 duration = 0 hours

## Priming the Pump

### CAUTION

This pump is shipped with Priming mode ENABLED. **Unless the Priming Speed has been modified, the pump will ramp up to 3450 RPM when powered on for the first time, and the Start/Stop button is pressed.**

Before turning the pump ON, be sure the following conditions are met:

1. Open filter air relief valve.
2. Open valves.
3. Pool return is completely open and clear of any blockages.
4. Water in the pump basket.
5. Stand clear of the filter or other pressurized vessels.

### WARNING

DO NOT run the pump dry. If the pump is run dry, the mechanical seal will be damaged and the pump will start leaking. If this occurs, the damaged seal must be replaced. ALWAYS maintain proper water level in your pool (half way up skimmer opening). If the water level falls below the skimmer opening, the pump will draw air through the skimmer, losing the prime and causing the pump to run dry, resulting in a damaged seal. Continued operation in this manner could cause a loss of pressure, resulting in damage to the pump case, impeller and seal and may cause property and personal injury.

Prime the pump before starting the pump for the first time. To avoid permanent damage to the pump, remove the lid and fill the basket with water. The pump basket must be filled with water before initial start-up or after servicing.

### Follow the steps below to prime the pump for start-up:

1. Press **Start/Stop** to stop the pump and disconnect power to the pump at the main circuit breaker.
2. Close all valves in suction and discharge pipes. Relieve all pressure from the system.
3. Remove the pump lid and locking ring. See **Figure 7**.
4. Fill the pump strainer pot with water.
5. Reassemble the pump lid and locking ring onto the strainer basket. The pump is now ready to prime.
6. Open all valves in suction and discharge pipes.
7. Open the filter air relief valve and stand clear of the filter.
8. Reestablish power to the pump and ensure green power light is on.
9. Press **Start/Stop** to start the pump. The pump will enter into priming mode (if enabled) and ramp up to the programmed priming speed.
10. When water comes out of the filter air relief valve, close the valve. The system should now be free of air and recirculating water to and from the pool.
11. The pump will prime for 5 minutes

**Note:** Do not allow the pump to run longer than 30 minutes time without developing full flow. If the pump does not prime, check your priming speed (see page 8, *Priming Adjustment*) or refer to the *Troubleshooting* section on pages 19-21.

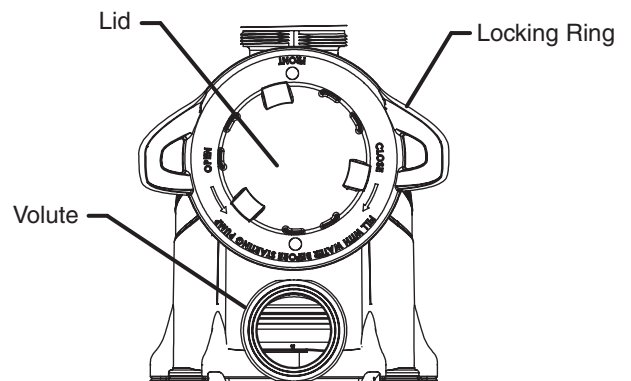

**Figure 7:** Top View of Pump

### CAUTION

Do not add chemicals to the system directly in front of pump suction. Adding undiluted chemicals may damage the pump and will void the warranty.

## Priming Adjustment

### CAUTION

This pump is shipped with Priming mode ENABLED. **Unless the Priming Speed has been modified, the pump will ramp up to 3450 RPM when powered on for the first time, and the Start/Stop button is pressed.**

Before turning the pump ON, be sure the following conditions are met:

1. Open filter air relief valve.
2. Open valves.
3. Pool return is completely open and clear of any blockages.
4. Water in the pump basket.
5. Stand clear of the filter or other pressurized vessels.

### WARNING

DO NOT run the pump dry. If the pump is run dry, the mechanical seal will be damaged and the pump will start leaking. If this occurs, the damaged seal must be replaced. ALWAYS maintain proper water level in your pool (half way up skimmer opening). If the water level falls below the skimmer opening, the pump will draw air through the skimmer, losing the prime and causing the pump to run dry, resulting in a damaged seal. Continued operation in this manner could cause a loss of pressure, resulting in damage to the pump case, impeller and seal and may cause property and personal injury.

Priming will automatically run when the WhisperFloXF® VS or Max-E-ProXF® VS Commercial Variable Speed Pump is started from a stopped state, except when running a Quick Clean cycle. Priming will run at 3450 RPM by default, and will last for 5 minutes. The drive's screen will display and cycle through the following things "Pr 1 -- Priming Speed, Pr 1 -- Remaining Time".

Once priming has begun, the speed can be adjusted between 3450 and 1700 RPM using the "+" and "-" arrows. If it is adjusted below 1700 RPM, Priming mode will be disabled and the pump will immediately begin to run the scheduled speed.

When priming is disabled and the pump is started from a stopped state, the screen will display, "Pr 1 -- OFF" for 10 seconds while running the scheduled speed (See **Figure 8**). This allows the user time to enable priming mode by pressing the "+" arrow. If the user chooses to re-enable priming mode, the pump will then transition from the scheduled speed to 1700 RPM. The user can increase the priming speed from 1700 RPM by pressing the "+" arrow. The 5 minute priming countdown timer starts when priming is first engaged.

The time the pump needs to achieve prime can change based on local environmental conditions such as water temperature, atmospheric pressure, and your pool's water level. All of these things should be taken into consideration when setting the priming speed, however in most cases the pump will not need to run at 3450 RPM to successfully prime itself.

Please test and verify chosen priming speeds more than once, letting the water drain from the system in between each test.

**Note:** The pump strainer basket should always remain full to the bottom of the inlet in order to prevent air from entering the system.

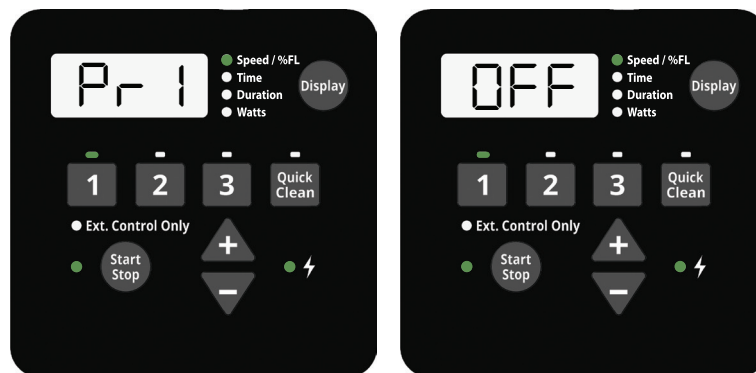

Figure 8: Priming Deactivation

## Operating the Pump While Running



If power is connected to the pump motor, pressing any of the following buttons referred to in this section could result in the motor starting. Failure to recognize this could result in personal injury or damage to equipment.

Pressing the **Display** button will cycle through the current parameters.

- **Speed / %FL** — current run speed or percent flow
- **Time** — current time of day
- **Duration** — amount of time remaining at the current PROGRAM
- **Watts** — amount of watts currently being consumed

Pressing any of the PROGRAM Buttons (“1”, “2”, “3”, “Quick Clean”) while the pump is running will act as temporary override. It will run the speed and duration that is programmed for that button. Once completed it will default back to the appropriate point in the programmed schedule.

**Note:** If you adjust the speeds of the schedule while the pump is running, it will run the adjusted speed for the rest of the current duration, but will not save the adjustments. **Exception: Speed and Duration adjustments to QUICK CLEAN will always be immediately saved.**

When running a Quick Clean cycle, pressing the “+” or “-” arrows will change the speed accordingly. Pressing the **Quick Clean** button again within 10 seconds after will allow for adjustment of the Quick Clean duration via the “+” and “-” arrows. These changes will be saved immediately and are the new defaults for Quick clean. Pressing the **Quick Clean** button again will cycle through the two Quick Clean settings. The pump will exit out of editing mode if no additional buttons are pressed within 10 seconds.

An active Quick Clean cycle can be stopped by holding the **Quick Clean** button for 3 seconds. The pump will then return to the appropriate point in its programmed schedule.



## Quick Clean

The pump is equipped with a Quick Clean feature, which can be engaged to temporarily run at higher or lower speeds ranging from 300 to 3450 RPM.

At the end of a Quick Clean cycle, the pump will automatically return to the appropriate point in its programmed schedule.

**Note:** Holding the **Quick Clean** button for more than three (3) seconds will cancel a Quick Clean cycle. The pump will then return to the appropriate point in its programmed schedule.

### Programming Quick Clean:

1. Stop the pump if it is running by pressing the **Start/Stop** button.
2. Press the **Quick Clean** button. The LED above the **Quick Clean** button and the “Spd / %FL” parameter LED will flash while editing. See **Figure 9**.



**Figure 9:** Setting Speed for Quick Clean

3. Use the “+” and “-” arrows to adjust the Quick Clean speed in RPM.
4. Press the **Quick Clean** button again and the display will change to Quick Clean duration. The “Duration” parameter LED will flash while editing. See **Figure 10**.

**Note:** It is recommended that you do not set the Quick Clean duration to 0 HRS. Setting the Quick Clean duration to 0 HRS will prevent edits to the duration setting while the motor is running. The motor will need to be stopped.

**Note:** Quick Clean duration does not affect the start or stop times of the 24 hour schedule. For example, if Quick Clean runs during a period overlapping with a later part of PROGRAM 1 and an early part of PROGRAM 2, the start time of PROGRAM 3 is not affected.



**Figure 10:** Setting Duration for Quick Clean

5. Use the “+” and “-” arrows to adjust the duration in hours and minutes for Quick Clean.
6. Press the **Start/Stop** button and ensure the LED is illuminated. The pump is now on and will run the speed and duration set for Quick Clean.

**Note:** During a Quick Clean cycle, the pump will not start with the priming sequence.

## Keypad Lockout

The pump has a Keypad Lockout feature to prevent unwanted changes to the pump settings. When locked, the keypad will only respond to:

- Pressing the **Display** button to cycle through current pump information.
- Pressing the **Start/Stop** button to stop the pump.

**Note:** The pump can not be manually restarted via the **Start/Stop** button until the keypad is unlocked.

If the pump is operated in Keypad Lockout mode, and being controlled through external controls, it can only run when the Start/Stop LED is illuminated.

### Programming a Lockout Code:

1. Hold the “1” and **Quick Clean** buttons for 3 seconds. “EntEr Loc CodE” will scroll across the screen.
2. Using the “1”, “2”, “3” and **Quick Clean** buttons, enter your desired four-digit keypad lockout code.
3. “Loc on” will scroll across the screen. Keypad Lockout is now active.

### Unlocking the Pump:

1. Hold the “1” and **Quick Clean** buttons for 3 seconds. “Enter Loc Code” will scroll across the screen.
2. Using the “1”, “2”, “3” and **Quick Clean** buttons, enter your four-digit keypad lockout code.

**Note:** If the lockout code is entered incorrectly, “Loc Err” will scroll across the screen. Repeat the steps above to enter the correct code.

**Note:** If your custom lockout code is forgotten, pressing **Quick Clean** -> **Quick Clean** -> “2” -> **Quick Clean** will erase the existing code and unlock the keypad.

3. “Loc oFF” will scroll across the screen. The keypad is now unlocked.

## Factory Reset

The drive can be reset to factory settings if necessary. A Factory Reset will wipe out all of the saved user settings that have been programmed, except for the time of day. Be sure that it is necessary before performing a Factory Reset, as the results are immediate.

### To perform a Factory Reset:

1. Stop the pump if necessary by pressing the **Start/Stop** button.
2. Record all of the custom schedule settings using **Table 2**. You can find these setting by pressing the “1”, “2”, “3”, and “**Quick Clean**” buttons and cycling through all the screens. Also write down the Priming Speed.
3. Hold the “1”, “2”, “3”, and “**Quick Clean**” buttons for 3 seconds.
4. The screen will display “Fact rSt” if factory reset is successful. See **Figure 11**.
5. Be sure to reprogram the schedule and priming speed after the factory reset. The pump must be turned back on with the **Start/Stop** button before it will run again. The pump will run the programmed schedule upon initial start-up.

**Note:** Factory Reset can not be performed from a Keypad Lockout state.

	Speed / Flow (RPM / %)	Duration (Hours)	Start Time (Time Clock)
PROGRAM 1			
PROGRAM 2			
PROGRAM 3			
QUICK CLEAN			
PRIMING SPEED			

Table 2: User Programmed Schedules

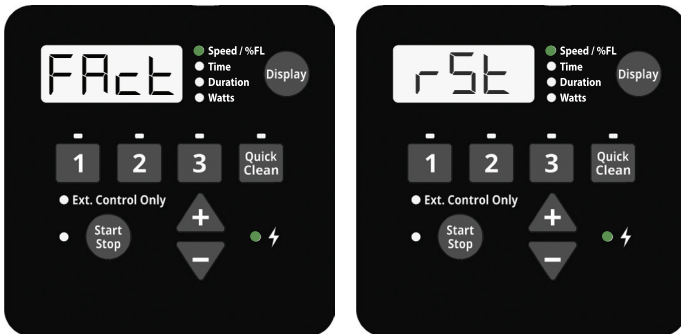

Figure 11: Drive Factory Reset

# EXTERNAL CONTROLS OR DIGITAL INPUTS

## Control with External Control and Digital Inputs

The WhisperFloXF® VS or Max-E-ProXF® VS Commercial Variable Speed Pump is compatible with external controls and digital inputs, allowing all four Programs to be controlled remotely. The pump has a sealed digital input port that can be used with Pentair External Control Wiring Kit (Pentair P/N 353129Z) to run the PROGRAMs using digital input signals. When there is an external low voltage signal present on any Digital Input line, the pump will run the settings programmed for that Digital Input. The supplied +5V signal is the recommended output used for external control and Digital Inputs.

## Connecting to External Controls

### Using the Supplied Low Voltage Signal for Digital Control

1. The pump provides a low voltage output signal that can be used to trigger its own Digital Inputs. This signal will need to be switched via the External Control system to engage the PROGRAM it is connected to (see **Figure 12**). This could be an automation relay or switch in another piece of equipment. This feature could be useful for ensuring that the pump is running a certain program when needed to perform a task.
2. The digital input cable included with the External Control Wiring Kit (Pentair P/N 353129Z) will need to be cut to length for the installation. Do not leave excess wire around the installation. The wire should be supported by something rigid if conduit is not used.  
At one end of the cable is a molded, watertight connection that plugs into the digital input port on the side of the drive. The opposite end has 6 wires that are defined by **Table 3** to the right. When using the +24V signal supplied by the drive, the PROGRAMs should be wired as shown in **Figure 12**.
3. When there is a low voltage signal present on the PROGRAM Digital Input line the pump will run the settings that are programmed for the PROGRAM that is being triggered. The +24V signal supplied via the red wire is the suggested input for the PROGRAM Digital Inputs. See **Figure 12**.

**Note:** Any relay can be associated to any Digital Input. **Figure 12** shows one of many potential wiring options available to the installer, allowing you to install External Controls in the way that best suits your needs.

**Note:** This +24V Signal (red wire) is output from the drive only, and should never be wired to another power supply!

When a Digital Input is triggered, the LED above the PROGRAM button will begin to blink and the display will toggle between the display parameter and “EC”. This indicates an External Control is running.

The pump will run the Digital Input as long as the Digital Input trigger is present and will override any schedules programmed via the keypad. The **Display** button is still functional along with the **Start/Stop** button.

Once the Digital Input trigger is removed from all of the Digital Input wires, the pump will resume all schedules programmed via the keypad.

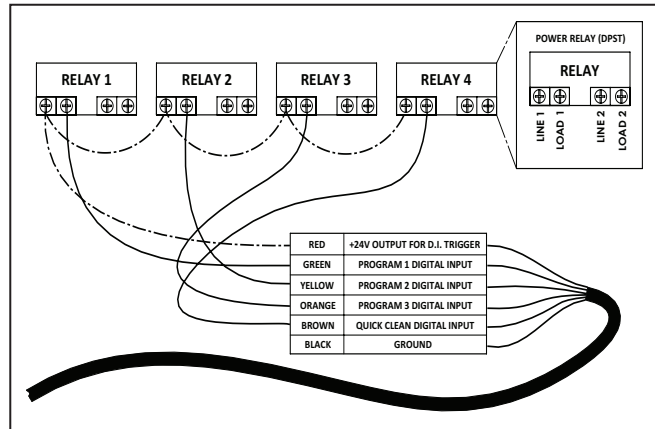

**Figure 12:** External Control Wiring Diagram

Definition	Signal Range	Wire Color
24 VDC Output for Digital Inputs *	0 - 20mA	Red
PROGRAM 1 Digital Input **	0, 5 - 30V AC/DC	Green
PROGRAM 2 Digital Input	0, 5 - 30V AC/DC	Yellow
PROGRAM 3 Digital Input	0, 5 - 30V AC/DC	Orange
Quick Clean Digital Input	0, 5 - 30V AC/DC	Brown
Common Ground	0V	Black

(\*) - When operating in flow mode, 24 VDC Output connection will provide flowmeter power.  
(\*\*) - When operating in flow mode, PROGRAM digital input 1 will be the flowmeter signal connection. PROGRAM digital inputs 2-3 and Quick Clean can be used for scheduling.

**Table 3:** External Control Wiring Chart

**Note:** If the pump has been stopped via the **Start/Stop** button, the pump will not run until the pump is turned back on by pressing the **Start/Stop** button. If the **Start/Stop** LED is illuminated, that indicates the pump is on and will run via Digital Inputs.

**Note:** When multiple low voltage triggers are present priority will be: QUICK CLEAN -> PROGRAM 3 -> PROGRAM 2 -> PROGRAM 1.

## External Control Only Mode

External Control Only mode will only allow the pump to run from external controls/inputs. When this mode is active the programmed pump schedule is deactivated, and user speed requests from the keypad will not be accepted. If the pump is stopped a user can still program the speeds for all four PROGRAM buttons.

### To activate External Control Only mode:

1. Stop the pump by pressing the **Start/Stop** button.
2. Activate External Control Only mode by holding the **Start/Stop** button for 10 seconds.
3. If successful the LED next to Ext. Control Only will illuminate. See **Figure 13**.
4. The **Start/Stop** button must be pressed again to allow the pump to run.

### To deactivate External Control Only mode:

5. Stop the pump by pressing the **Start/Stop** button.
6. Deactivate External Control Only mode by holding the **Start/Stop** button for 10 seconds.
7. If successful the LED next to Ext. Control Only will turn off.
8. The **Start/Stop** button must be pressed again to allow the pump to run.



**Figure 13:** External Control Only Mode

## Operating the Pump in Flow Mode

When connected to an inline 4-20mA flowmeter, this pump is capable of maintaining a constant flow based on the needs of your pool system.

Connecting a flowmeter and operating the pump in flow mode will require the purchase of:

- External Control Wiring Kit (P/N 353129z)
- A 4-20mA Flowmeter (Pentair recommends P/N 97014-4203KIT)

## Flow Mode Setup and Configuration

Before beginning flow mode setup and configuration, ensure the pool filter has been backwashed and all pump and skimmer baskets are free of debris.

1. Stop the pump if it is running by pressing the **Start/Stop** button.
2. Following the installation instructions given in the flowmeter's installation guide, install an inline 4-20mA flowmeter into the plumbing.
3. Using the External Control Wiring Kit, connect the flowmeter to the digital input port on the side of the pump drive. See **Figure 14**.

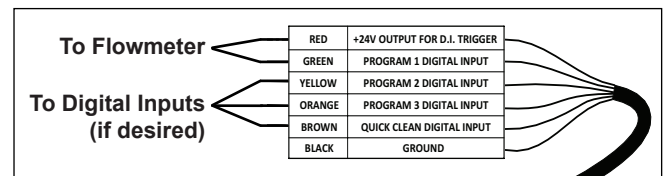

**Figure 14:** Flowmeter Wiring Diagram

4. Hold the **Display** button for 3 seconds.
5. Press the **Display** button three times to access the Speed or Flow mode selection screen. "Spd" will display.
6. Use the "+" and "-" arrows to scroll to "Flo". See **Figure 15**.

**Note:** This option will not be available unless a 4-20mA flowmeter is connected to the pump.



**Figure 15:** Setting Flow Mode

7. Press the **Display** button to access the Flow Mode High Speed screen.

- Continue to next page -

## Flow Mode Setup and Configuration (cont.)

8. Use the “+” and “-” arrows to set high speed for flow mode between 2000 and 3450 RPM.
9. Press the **Display** button. “Press Start” will scroll across the screen.
10. Press the **Start/Stop** button and the pump will ramp up to the programmed maximum speed, then “Config Flo Sensor” will scroll across the screen.
11. At the flowmeter, configure the flowmeter to values or within ranges given below:

**K Factor:** Refer to flowmeter manual

**Averaging:** 10-30 (20 is recommended)

**Sensitivity:** Refer to flowmeter manual

**4-Set:** 0 GPM

**20-Set:** GPM displayed while pump motor is at maximum speed set in step 8.

**Note:** Flowmeter configuration will timeout at the drive after 10 minutes. If this occurs, repeat steps 4 through 10.

**Note:** The flowmeter 20-Set will need to be reconfigured each time the system’s filter is cleaned.

12. At the pump, press the **Display** button to continue through flow mode configuration.

**Note:** If the pump displays “LoFlo” or “HiFlo” and a percentage other than “100” (see **Figure 16**), adjust 20-set setting at the flowmeter until the pump displays “100”.



**Figure 16:** Low Flow Alarm

13. “Aver” will display (see **Figure 17**). Use the “+” and “-” arrows to match the flowmeter’s averaging value.



**Figure 17:** Averaging Configuration

14. Press the **Display** button. “Auto Tuning” will scroll across the screen as the pump auto tunes. The motor will drop to half speed and then slowly ramp down until the minimum controllable flow is found.

**Note:** Auto Tuning process will take several minutes to complete, or much longer in installations with longer plumbing systems.

15. Motor will stop when Auto Tuning completes. Flow Mode setup is now complete.

16. Refer to *OPERATION* section (pages 5-11) to continue pump programming.

## Adjusting Flow Setting

1. Use the “+” and “-” arrows to increase or decrease the Flow Percentage. This percentage is based on the high speed set during Flow Mode setup and configuration.

**Example:** If flow mode maximum speed is 3000 RPM, lowering flow percentage to “50” will decrease motor RPMs until the pump is producing 50% of the flow created at 3000 RPM.



# MAINTENANCE

**⚠ WARNING** **DO NOT** open the strainer pot if pump fails to prime or if pump has been operating without water in the strainer pot. Pumps operated in these circumstances may experience a build up of vapor pressure and may contain scalding hot water. Opening the pump may cause serious personal injury. In order to avoid the possibility of personal injury, make sure the suction and discharge valves are open and strainer pot temperature is cool to touch, then open with extreme caution.

**⚠ CAUTION** To prevent damage to the pump and for proper operation of the system, clean pump strainer and skimmer baskets regularly.

## Cleaning the Pump Strainer Basket

The strainer basket, is located in front of the WhisperFloXF® VS or Max-E-ProXF® VS Commercial Variable Speed Pump housing. The strainer basket must be kept clean and free of debris. Inspect basket through the lid on the top of the housing. Be sure to visually inspect the strainer basket at least once a week. Dirty strainer baskets reduce filter and heater efficiency and put abnormal stress on the pump motor.

1. Press **Start/Stop** to stop the pump and disconnect power to the pump at the main circuit breaker.
2. Relieve pressure in the system.
3. Turn the lid and locking ring counter-clockwise and remove from the pump.
4. Remove debris and rinse out the basket. Replace the basket if it is cracked.
5. Put the basket back into the housing. Be sure to align the rib on the basket with the notch in the volute.
6. Fill the pump pot and volute up to the inlet port with water.
7. Clean the lid and locking ring, O-ring, and sealing surface of the pump pot.
 

**Note:** It is important to keep the lid O-ring clean and well lubricated.
8. Reinstall the lid by placing the locking ring and lid on the pot. Be sure the lid O-ring is properly placed. Seat the locking ring and lid on the pump then turn clockwise until the locking ring handles are horizontal.
 

**Note:** Ensure that the side of the lid/locking ring marked "Front" is positioned at the front of the pump.
9. Return power to the pump at the circuit breaker.
10. Open the manual air relief valve on the top of the filter. Stand clear of the filter.
11. Wait until all pressure is relieved. Start the pump.
12. Bleed air from the filter until a steady stream of water comes out of the filter air relief valve. Close the manual air relief valve.

**⚠ WARNING** **THIS SYSTEM OPERATES UNDER HIGH PRESSURE.** When any part of the circulating system (e.g., Lock Ring, Pump, Filter, Valves, etc.) is serviced, air can enter the system and become pressurized. Pressurized air can cause the lid to separate which can result in serious injury, death, or property damage. To avoid this potential hazard, follow above instructions.



## Winterizing

You are responsible for determining when freezing conditions may occur. If freezing conditions are expected, take the following steps to reduce the risk of freeze damage. **Freeze damage is not covered under warranty.**

**To prevent freeze damage, follow the procedures below:**

1. Press the **Start/Stop** button to stop the pump and shut off electrical power for the pump at the circuit breaker.
2. Drain the water out of the pump housing by removing the two thumb-twist drain plugs from the housing. Store the plugs in the pump basket.
3. Cover the motor to protect it from severe rain, snow and ice.

**Note:** Do not wrap motor with plastic or other air tight materials during winter storage. The motor may be covered during a storm, winter storage, etc., but never when operating or expecting operation.

**Note:** In mild climate areas, when temporary freezing conditions may occur, run your filtering equipment all night to prevent freezing.

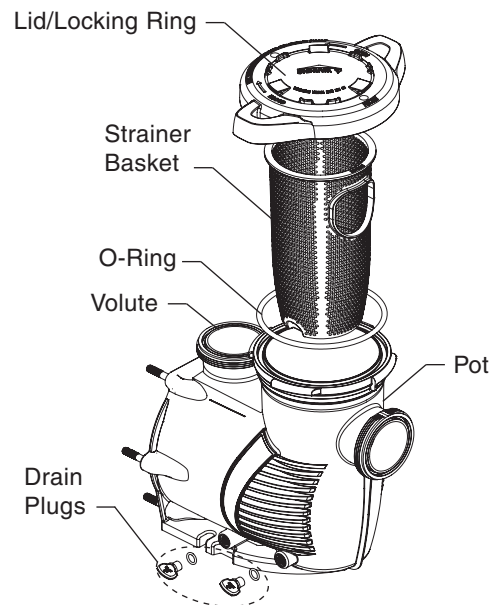

**Strainer Pot Assembly**

# SERVICING

**⚠ WARNING** Always disconnect power to the WhisperFloXF® VS or Max-E-ProXF® VS Commercial Variable Speed Pump at the circuit breaker and disconnect the digital input cable before servicing the pump. Failure to do so could result in death or serious injury to service people, users or others due to electric shock. Read all servicing instructions before working on the pump.

**⚠ WARNING** **DO NOT** open the strainer pot if pump fails to prime or if pump has been operating without water in the strainer pot. Pumps operated in these circumstances may experience a build up of vapor pressure and may contain scalding hot water. Opening the pump may cause serious personal injury. In order to avoid the possibility of personal injury, make sure the suction and discharge valves are open and strainer pot temperature is cool to touch, then open with extreme caution.

**⚠ CAUTION** Be sure not to scratch or mar the polished shaft seal faces; seal will leak if faces are damaged. The polished and lapped faces of the seal could be damaged if not handled with care.

## Motor and Drive Care

### Protect from heat

1. Shade the motor from the sun.
2. Any enclosure must be well ventilated to prevent overheating.
3. Provide ample cross ventilation.

### Protect against dirt

1. Protect from any foreign matter.
2. Do not store (or spill) chemicals on or near the motor.
3. Avoid sweeping or stirring up dust near the motor while it is operating.
4. If a motor has been damaged by dirt it may void the motor warranty.
5. Clean the lid and locking ring O-ring, and sealing surface of the pump pot.

### Protect against moisture

1. Protect from continuous splashing or continuous sprayed water.
2. Protect from extreme weather such as flooding.
3. If motor internals have become wet - let them dry before operating. Do not allow the pump to operate if it has been flooded.
4. If a motor has been damaged by water it may void the motor warranty.

## The Mechanical Seal

The mechanical seal consists primarily of two parts, a rotating ceramic seal housed in the impeller and a stationary spring seal in the sealplate. The pump requires little or no service other than reasonable care. A mechanical seal may occasionally become damaged and must be replaced.

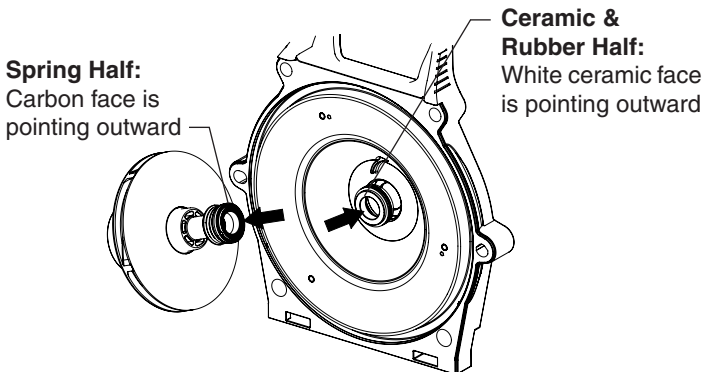

**Mechanical Seal**

## Pump Disassembly

Tools required:

- 1/4-inch Hex Allen wrench
- T20 Star-head Driver
- 9/16-inch wrench
- 3/4-inch socket wrench
- 9/64-inch Hex key wrench

**To remove and repair the motor assembly, follow the steps below:**

1. Turn off the pump circuit breaker at the main panel.
2. Drain the pump by removing the drain plugs.
3. Disconnect any digital inputs from the pump (if connected).
4. Remove the four (4) star-head screws from the top of the drive cover.
5. Disconnect the drive **cover** from the drive and set it to the side in a safe place.
6. Remove the four (4) star-head screws securing the drive to the motor. Two (2) screws are located under the drive and two (2) are located inside the drive.
7. Remove the drive by lifting upwards to separate it from the motor.
8. Using a 9/16-inch wrench, remove the six (6) nuts securing the volute to the seal plate/motor assembly.
9. Gently pull the two pump halves apart.
10. Using a 9/64-inch hex key wrench, remove the three (3) screws securing the diffuser to the seal plate.
11. Hold the impeller securely in place by hand. Remove the impeller lock screw located at the center of the impeller, using a deep well 3/4-inch socket and wrench. The screw is a left-handed thread and loosens in a clockwise direction. Remove the impeller screw o-ring. Inspect the o-ring for damage, cracks etc. Replace if damaged.

**⚠ CAUTION** The pump impeller may have sharp edges that could potentially cut or scratch the user's hands. Pentair recommends that safety gloves be worn when holding the impeller during disassembly and reassembly.

12. Using the 1/4-inch Allen wrench to hold the motor shaft, twist the impeller counter-clockwise to remove it from the shaft.
13. Using a 9/16-inch wrench, remove the four (4) nuts securing the seal plate to the motor.
14. Place the seal plate face down on a flat surface and press out the ceramic part of the mechanical seal.
15. Clean the seal plate, seal housing, and the motor shaft.

*Pump illustrated parts view on the next page*

## Pump Reassembly/Seal Replacement

1. Install the **spring end** of the mechanical seal onto the impeller shaft. Be sure **black/carbon** face is facing outward.
  2. Remount the seal plate to the motor using the four (4) motor nuts and washers.
  3. With the white ceramic face facing outward, press the seal into the seal plate with your thumbs and wipe off the ceramic with a clean cloth. Do not lubricate seal faces.
  4. Hand tighten impeller onto the motor shaft.
  5. Screw in the impeller reverse lock screw (counter-clockwise to tighten).
  6. Remount the diffuser onto the seal plate. Make sure the plastic pins and holding screw inserts are aligned (see "TOP" indicator).
- Note:** Ensure that the seal plate o-ring is clean and free of debris.
7. Assemble the motor subassembly to the housing. Do not tighten the nuts and washers until all four (4) motor nuts are in place. Using a torque wrench, install and tighten the six (6) seal plate nuts and washers to a torque value of 100 in-lbs (maximum). Do not overtighten the nuts.
  8. Reinstall the drive onto the top of the motor.
  9. Fill the WhisperFloXF® VS or Max-E-ProXF® VS Commercial Variable Speed Pump with water.
  10. Reinstall the pump lid and locking ring; see "Cleaning the Pump Strainer Basket" on page 15.
  11. Prime the system. See page 7 for priming instructions.

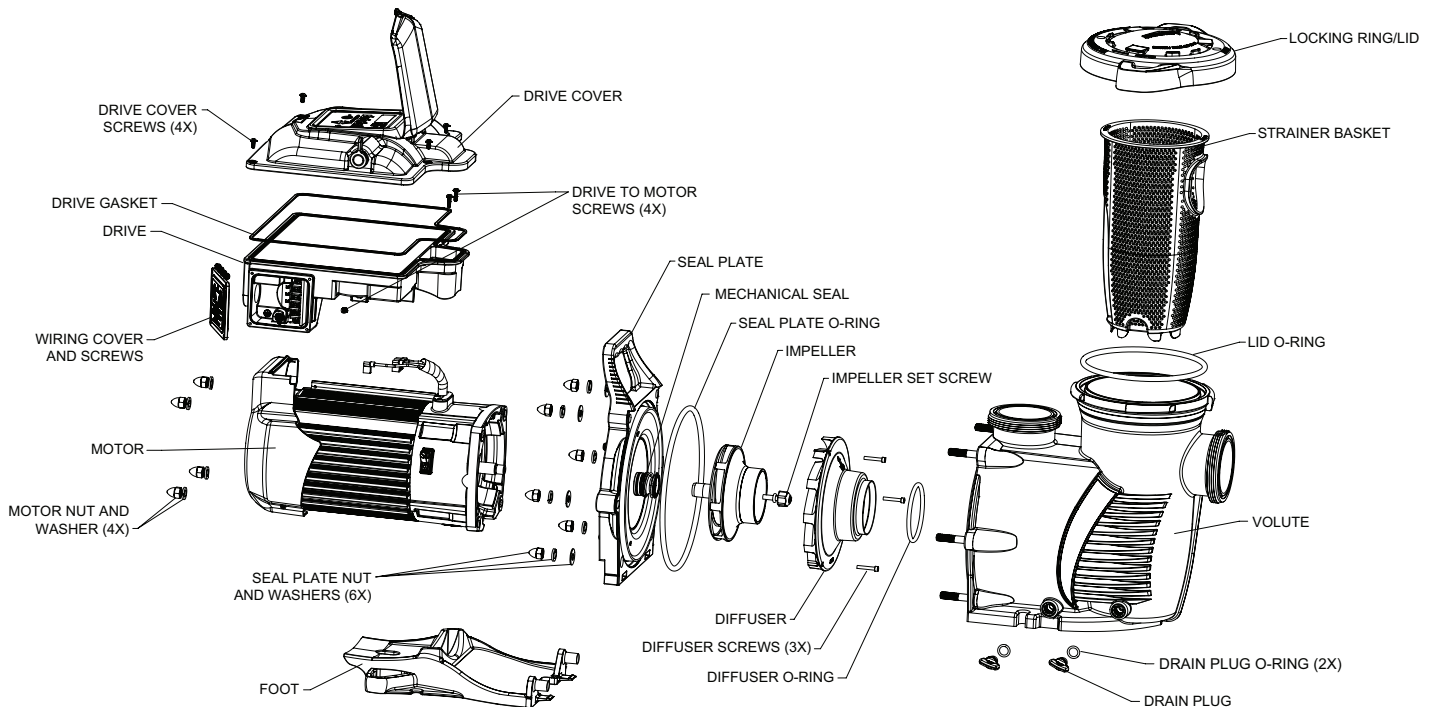

**Pump Illustrated Parts View**

## Removing and Replacing the Drive Assembly

### Removing the Existing Drive Assembly:

1. If possible, record your programmed schedule and priming speed before proceeding.
2. Disconnect power to the pump at the circuit breaker. **Wait five (5) minutes after disconnecting the power before removing the drive cover.**
3. Using a #2 Phillips-head screwdriver, uninstall the field wiring compartment cover from the side of the drive. Place the cover and all screws aside.
4. Uninstall field wiring, strain relief and/or conduit from the drive.
5. Using a T20 star-head screwdriver, remove the four (4) Drive Cover Screws (**Figure 18**).
6. Gently lift the drive cover and disconnect the keypad cable from the Keypad Terminal (**Figure 19**). Place the drive cover aside.
7. Carefully disconnect the four (4) white Motor Connections (**Figure 19**) from their flag terminals. **Note:** Take note of which flag terminal each cable is paired with. Each connector must be installed to the same flag terminal when installing the new drive.
8. Using a T20 star-head screwdriver, remove the two (2) Front Drive-to-Motor Screws (**Figure 19**).
9. Using a T20 star-head screwdriver, remove the two (2) Rear Drive-to-Motor Screws (**Figure 20**) from underneath the drive.
10. Lift the drive away from the motor, carefully guiding the motor cables through the opening in the front of the drive. Place the old drive aside.

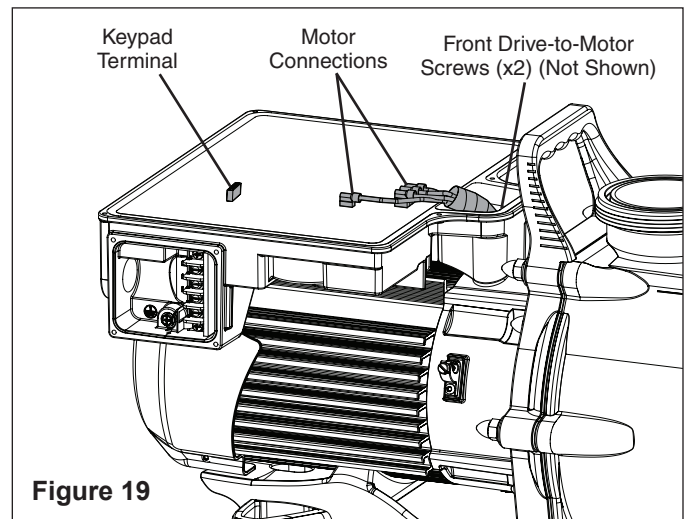
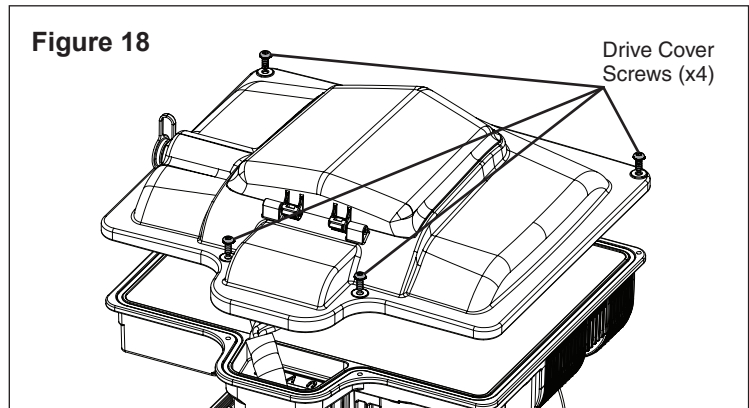

### Installing the New Drive Assembly:

11. Place the new drive onto the motor, carefully feeding the Motor Connectors through the opening in the front of the drive.
12. Reinstall the four (4) Drive-to-Motor Screws (**Figures 19 and 20**).
13. Referring back to the notes taken in Step 7, plug each motor cable into its corresponding flag terminal.
14. Reconnect the drive cover's keypad connector to the drive and seat the drive cover onto the drive body.
15. Reinstall the four (4) Drive Cover Screws (**Figure 18**).
16. Reconnect the Main Power supply and strain relief or conduit for the electrical wires.
17. Reinstall the field wiring compartment cover using the four (4) cover screws.
18. Return power to the pump at the circuit breaker.
19. Your pump's time, schedule and priming speed will need to be reprogrammed. Refer to the *OPERATION* section for programming procedures.

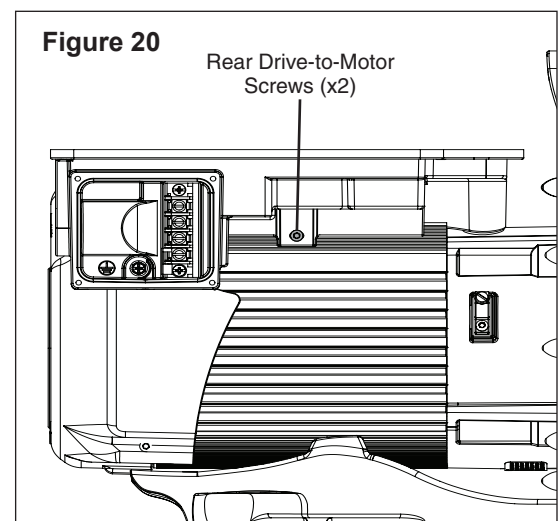

# TROUBLESHOOTING

**WARNING**

Always disconnect power to the pump at the circuit breaker and disconnect the digital input cable before servicing the pump. Failure to do so could result in death or serious injury to serviceman, pool users or others due to electric shock. DO NOT attempt to adjust or service without consulting your dealer or a qualified pool technician. Read the entire Installation & User's Guide before attempting to use, service, or adjust the pool filtering system or heater.

Problem	Possible Cause	Corrective Action
<b>Pump failure.</b>	Pump will not prime - Air leak in suction.	Check suction piping and valve glands on any suction gate valves. Secure lid on pump strainer pot and be sure lid gasket is in place. Check water level to be sure skimmer is not drawing air.
	Pump will not prime - Not enough water.	Be sure the suction lines, pump, strainer, and pump volute are full of water. Be sure valve on suction line is working and open (some systems do not have valves). Check water level to make sure water is available through skimmer.
	Pump strainer basket is clogged.	Clean pump strainer basket.
	Pump strainer gasket is defective.	Replace gasket.
<b>Reduced capacity and/or head.</b>	Air pockets or leaks in suction line.	Check suction piping and valve glands on any suction gate valves. Secure lid on pump strainer pot and be sure lid gasket is in place. Check water level to be sure skimmer is not drawing air.
	Clogged impeller.	Turn off electrical power to the pump. Disassemble (see page 16, 'Pump Disassembly') Clean debris from impeller. If debris cannot be removed, complete the following steps: <ol style="list-style-type: none"> <li>1. Remove left hand thread anti-spin bolt and o-ring.</li> <li>2. Remove, clean, and reinstall impeller.</li> <li>3. Reassemble (see page 17, 'Pump Reassembly')</li> </ol>
	Pump strainer basket clogged.	Clean suction trap. Clean pump strainer basket.
<b>Pump fails to start.</b>	Main voltage is not present.	<ol style="list-style-type: none"> <li>1. Replace fuse, reset breaker/GFCI.</li> <li>2. Tighten main wire connections.</li> </ol>
	Pump shaft is locked.	Check if the pump can be rotated by hand and remove any blockage.
	Pump shaft is damaged.	Replace pump.
<b>Pump runs then stops.</b>	"0004" over-temperature alarm.	Check that back of pump is free from dirt and debris. Use compressed air to clean.
	"0017" over-current alarm.	Inspect drive to motor connection terminals.
<b>Pump is noisy.</b>	Debris in contact with fan.	Check that back of pump is free from dirt and debris. Use compressed air to clean.
	Debris in strainer basket.	Clean pump strainer basket.
	Loose mounting.	Check that mounting bolts of pump and pump are tight.
<b>Inadequate circulation.</b>	Filter or pump basket dirty.	Check pump strainer basket; if logged, turn pump off and clean basket. Check and clean pool filter.
	Suction/discharge piping is too small.	Increase piping size.
	Speed is set too slow for proper filtration cycle.	Increase filtration run time.



## Troubleshooting, (continued)

Problem	Possible Cause	Corrective Action
<b>Pump runs without flow.</b>	Impeller is loose.	Check that pump is spinning by looking at fan on back of motor. If so, check that pump impeller is correctly installed.
	Air leak.	Check plumbing connections and verify they are tight.
	Clogged or restricted plumbing or strainer basket.	Check for blockage in strainer basket or suction side piping. Check for blockage in discharge piping, including partially closed valve or dirty pool filter.
<b>“LoFlo” or “HiFlo” alarm.</b>	Flowmeter 20-set setting is too high (Low Flow alarm) or too low (High Flow alarm).	Clean the pool filter, pump strainer basket and all skimmer baskets. Recalibrate the flowmeter 20-set (refer to page 14 and/or flowmeter manual).
<b>Electrical problem.</b>	Could appear as a “000E” low voltage alarm.	Check voltage at motor terminals and at panel while pump is running. If low, see wiring instructions or consult power company. Check for loose connections.
	Could appear as “0017” overheat alert.	Check line voltage; if less than 90% or more than 110% of rated voltage consult a licensed electrician. Increase ventilation. Reduce ambient temperature. Inspect drive to motor connection terminals. Motor runs too hot. Turn power to motor off. Check for proper voltage. Check for proper impeller or impeller rubbing.
<b>Mechanical troubles and noise.</b>	The pump motor is running but with loud noise.	If suction and discharge piping are not adequately supported, pump assembly will be strained. Do not mount pump on a wooden platform! Securely mount on concrete platform for quietest performance.
	Foreign matter (gravel, metal, etc.) in pump impeller.	Disassemble pump, clean impeller, follow pump service instructions for reassembly.
	Cavitation.	Improve suction conditions. Increase pipe size. Decrease number of fittings. Increase discharge pressure.
	Speaking noise, especially evident at pump start-up or slow down.	Inspect motor slinger and motor shaft seal behind the slinger (NOT the pump’s mechanical seal). Apply lubrication to the motor shaft rubber seals.
<b>Pump does not respond to external controls.</b>	Improper external control, digital input or flow control setup.	Be sure that the digit input cable is connected at both ends.

## Faults and Alarms

If an alarm is triggered the drive's LCD screen will display the fault code text and the WhisperFloXF® VS or Max-E-ProXF® VS Commercial Variable Speed Pump will stop running. Disconnect power to the pump and wait until the keypad LEDs have all turned off. At this point, reconnect power to the pump. If the error has not cleared then proper troubleshooting will be required. Use the error description table below to begin troubleshooting.

FAULT CODE	DESCRIPTION
000A	Absolute L4 inductor temperature limit exceeded
000b	DC bus over voltage detected
000c	DC bus under voltage detected
000d	Absolute AC line over voltage detected
000E	Absolute AC line under voltage detected
000F	Internal voltage ref out of range
00 1A	Input bypass relay fault detected
0002	Absolute phase current limit exceeded
0004	Absolute Power Module temperature limit exceeded
0006	Absolute Power Factor Correction (PFC) temperature limit exceeded
0008	Absolute Diode Bridge temperature limit exceeded
00 10	External voltage ref out of range
00 11	Module therm out of range
00 12	PFC therm out of range
00 13	Bridge therm out of range
00 14	L4 Inductor therm out of range
00 15	Current offset out of range
00 16	Motor start fault detected
00 17	Power module over current detected
00 18	3 phase current imbalance detected
00 19	Module fault test failure
002 1	Communication link between HMI and motor control has been lost

**002 1 – Communication Link between the HMI and Motor control has been lost:** Check the jacketed wire on the back side of the keypad inside the drive top cover. Ensure that the 5 pin connector is properly plugged into the socket and that there is no damage to the cable.

**00 17 – Power Module over current detected:** If this error displays multiple times, then there may be a problem with the pump's rotating assembly. Please disassemble the pump and investigate to see if there is a problem with the impeller or mechanical seal. See page 16 "*Pump Disassembly*" for instructions for disassembling the pump.

**000E – Absolute AC Under Voltage Detected:** This indicates that the supply voltage has dropped below the operating range of 187v. This could be caused by normal voltage variation and will clear itself. Otherwise there could be excess voltage sag caused by improper installation or improper supply voltage.

# REPLACEMENT PARTS

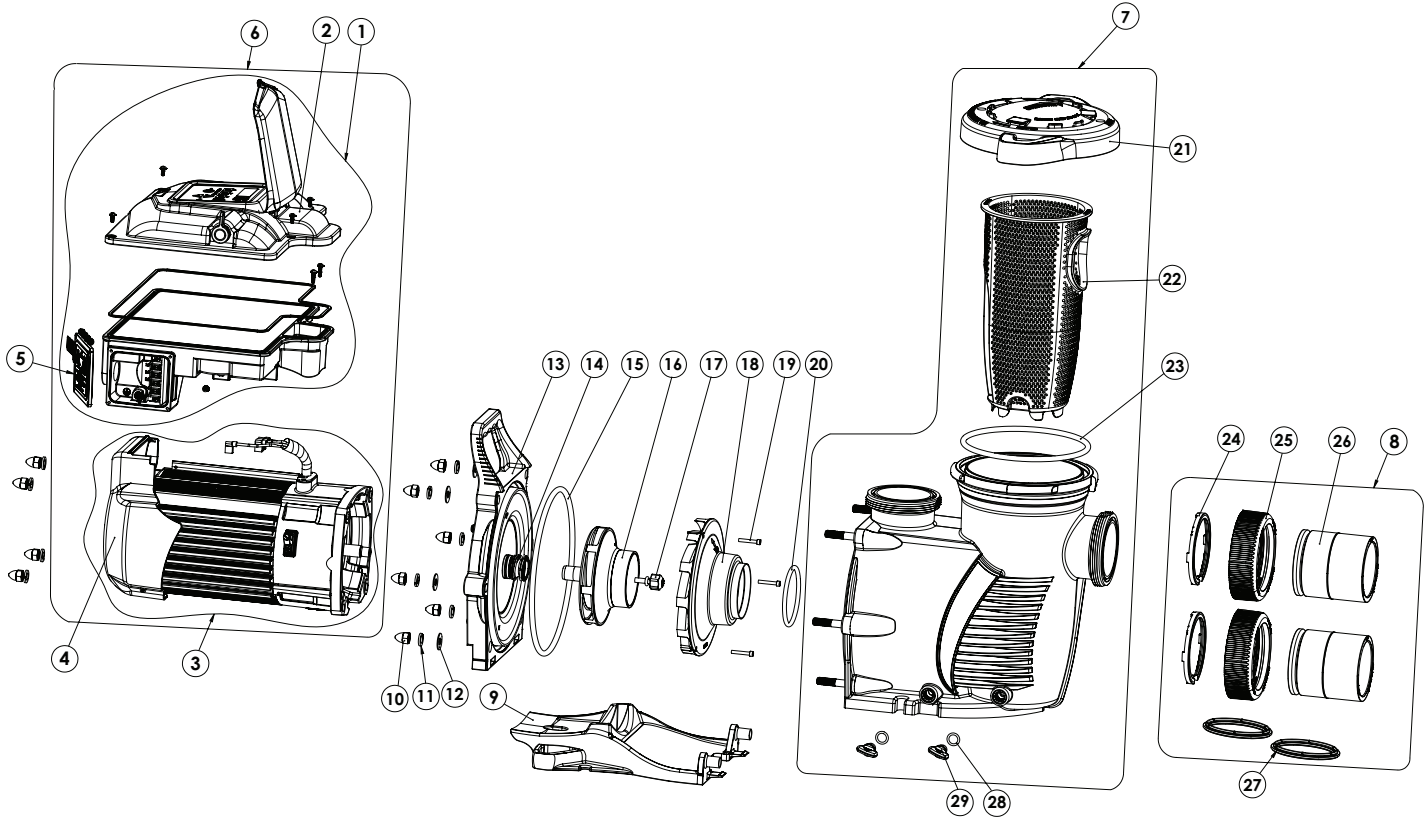

## Replacement Parts List

Item No.	Description	Whisper-FloXF VS Part #	Max-E-ProXF VS Part #
1	Drive Kit*	358085	358086
2	Top Cover Kit w/ Screws	358093	358094
3	Motor w/ Fan Shroud	358089	358090
4	Fan Shroud w/ Screws	358095	358096
5	Field Wiring Cover w/ Screws	358091	358092
6	Motor/Drive Assembly	358079s	358080s
7	Wet End Assembly	400000	401000
8	Union Kit	410020	
9	Motor Base	400004Z	401004Z
10	Acorn Nut (Qty. 10)	071413	
11	Lock Washer (Qty. 10)	U43-12SS	
12	Flat Washer (Qty. 6)	072184	
13	Seal Plate	400002	401002
14	Mechanical Seal	17351-0101S	
15	Seal Plate O-Ring	351446	
16	Impeller	400023	
17	Impeller Set Screw	37337-6080	

Item No.	Description	Whisper-FloXF VS Part #	Max-E-ProXF VS Part #
18	Diffuser	400011	
19	Diffuser Screws	353323	
20	Diffuser O-Ring	350336	
21	Lid/Locking Ring Assembly	400006	401006
22	Strainer Basket	400007Z	
23	Lid/Locking Ring O-Ring	35505-1440	
24	2.5" C-Clip Locking Ring (Qty. 2)	410001	
25	2.5" Union Nut (Qty. 2)	411000	
26	2.5" Union Adapter w/o Tap (Qty. 2)	410002	
27	2.5" Diamond Seal Kit (Qty. 2)	410016Z	
28	Drain Plug O-Ring (Qty. 2)	192115	
29	Drain Plug (Qty. 2)	071131	357161
-	External Control Wiring Kit	353129Z	
-	3-inch Flowmeter Kit	97014-4203KIT	

(-) Not Shown

\*NOTE: Drive Kit includes drive, top cover, keypad cover and field wiring cover/screws.

### Performance Curves

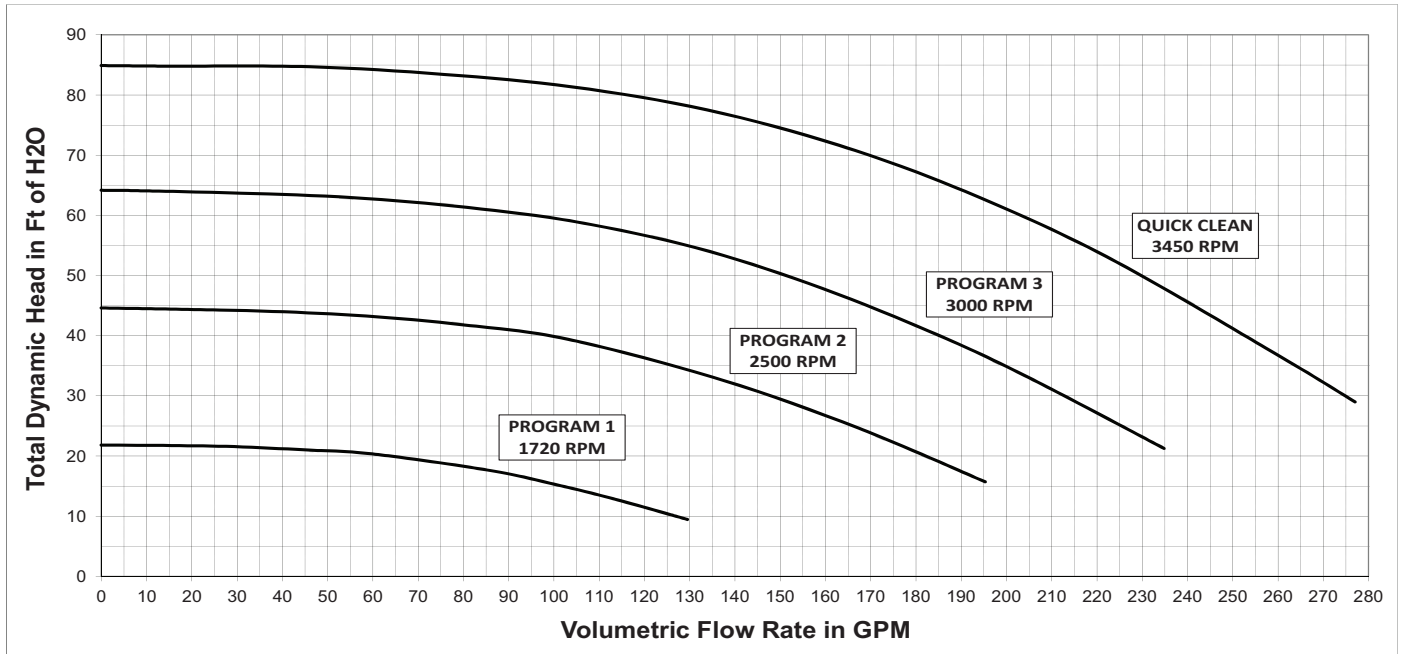

### Pump Dimensions

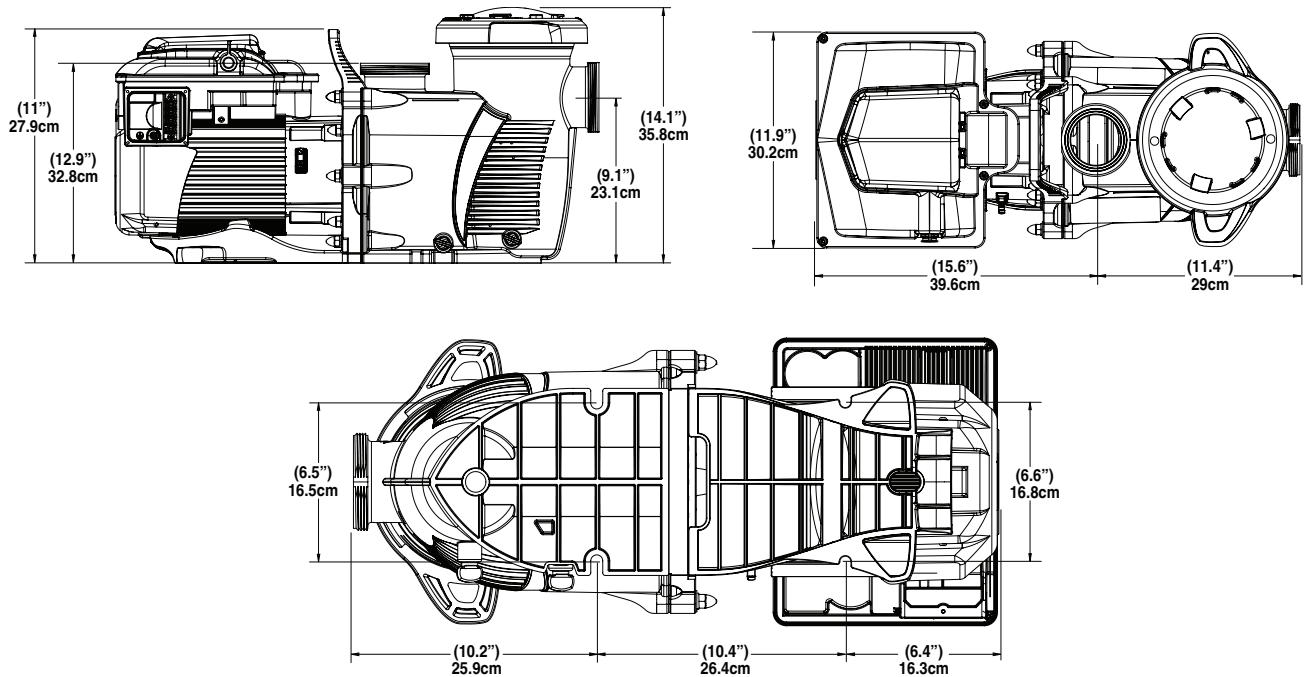

### Electrical Specifications

<b>Voltage</b>	1PH: 208-230/277-460V 3PH: 208-460V
<b>Max Amps</b>	1PH: 20-21/17-11A 3PH: 13-6A
<b>WEF / THP</b>	WEF 5.0 THP 5.0
<b>Frequency</b>	50/60 Hz

### Mechanical Specifications

<b>Speed Range</b>	300-3450 RPM
<b>Maximum Continuous Load (Total HP)</b>	5
<b>Ambient Conditions</b>	<b>Storage:</b> -40°F - 185°F (-40°C - 85°C) <b>Operating:</b> 32°F - 122°F (0°C - 50°C) <b>Humidity:</b> Relative 0 to 95% non-condensing



1620 HAWKINS AVE., SANFORD, NC 27330 • (919) 566-8000  
10951 WEST LOS ANGELES AVE., MOORPARK, CA 93021 • (805) 553-5000

[WWW.PENTAIR.COM](http://WWW.PENTAIR.COM)

All Pentair trademarks and logos are owned by Pentair or one of its global affiliates. Sta-Rite®, WhisperFloXF™ and Max-E-ProXF™ are trademarks and/or registered trademarks of Pentair Water Pool and Spa, Inc. and/or its affiliated companies in the United States and/ or other countries. Unless expressly noted, names and brands of third parties that may be used in this document are not used to indicate an affiliation or endorsement between the owners of these names and brands and Pentair Water Pool and Spa, Inc. Those names and brands may be the trademarks or registered trademarks of those third parties. Because we are continuously improving our products and services, Pentair reserves the right to change specifications without prior notice. Pentair is an equal opportunity employer.

© 2019 Pentair Water Pool and Spa, Inc. All rights reserved. This document is subject to change without notice.



P/N 358077 REV. A 5/16/19