

# CHEM-FEED<sup>®</sup>

Engineered Skid Systems



CFPS-2 Dual pump system



CFPS-1 Single pump system

Note: Your Chem-Feed Engineered Skid System may be designed differently from above photos.



**ProSeries<sup>®</sup>**  
by Blue-White Ind.

5300 Business Drive, Huntington Beach, CA 92649 USA

Phone: 714-893-8529 FAX: 714-894-9492

E mail: [sales@blue-white.com](mailto:sales@blue-white.com) or [techsupport@blue-white.com](mailto:techsupport@blue-white.com) URL: [www.blue-white.com](http://www.blue-white.com)

## TABLE OF CONTENTS

<u>Section</u>	<u>Heading</u>	<u>Page</u>
1.0	Introduction	2
2.0	Specifications	3
3.0	Dimensions	4
4.0	Features	5
5.0	Chem-Feed® Matrix	6
6.0	Mounting a pump to the system (single and dual)	7
7.0	Component Identification and Typical Operation - Single Pump	8
7.1	How to Operate the Chem-Feed® Skid System - Single Pump	9
8.0	Component Identification and Typical Operation - Dual Pump	10
8.1	How to operate the Chem-Feed Skid System - Dual Pump	11

### 1.0 Introduction

Congratulations on purchasing the Chem-Feed® Engineered Plastic Skid System. The system is designed with the necessary components to safely inject liquid chemical into a system.

Your Chem-Feed® Engineered Plastic Skid System is pre-configured based on your selections via the matrix or when designed with our engineering staff.



**Please Note:** Your new Chem-Feed® System has been pressure tested at the factory with clean water for a minimum of four hours before shipping. You may notice trace amounts of clean water in the system. This is part of our stringent quality assurance program at Blue-White Industries.

## 2.0 Specifications

Items listed below are standard available items and ship with most configurations. Your system may be customized with components not listed below.

### Skid

Chemically resistant polyethylene structure.

### Pump (sold separately)

Flex-Pro model A2, A3 or A4 peristaltic pumps or Chem-Pro model C2 or C3 diaphragm pump. See page 6 for metering pump data.

### Piping

PVC Schedule 80 (optional CPVC).

### Seals

FKM seals (optional EPDM).

### Tubing (T)

Reinforced braided PVC, 200 psi max, meets NSF std. 51. The pump inlet and outlet flexible tubing connections are terminated to half unions and secured to the barbed fitting with stainless steel clamps.

### Tubing clamps

300 series SS band, 400 series SS screw

### Unions (U)

PVC body, schedule 80

### Ball valves (V)

True unions, PVC body, PTFE shaft bearings and seats

### Pressure Relief Valve (PRV)

PVC body, PTFE primary diaphragm seal. Non-wetted components: EPDM secondary seal, zinc plated steel spring, stainless steel external hardware, HDPE pressure adjustment screw. Infinite adjustment from 10-150 psi.

### Calibration Cylinder (CC)

PVC body, PVC end caps, 1/2" PVC pipe outlet vent.

Available volumes: 1.6 GPH (100ml), 4 GPH (250ml), 8 GPH (500ml), 16 GPH (1000ml), 32 GPH (2000ml), and 64 GPH (4000mL).

### Pulsation Dampener (PD)

CPVC body, 10 cubic inch volume

### Gauge w/guard (G)

Gauge: liquid filled stainless steel with blowout plug, bottom mount, 1/4" NPT theads. Available pressure ranges: 0-30 psi, 0-100, psi, 0-200 psi.

Guard: PVC body, temperature compensated oil filled.

### Check Valve (CV)

PVC body. Cracking pressure: 1.0-1.5 psi. Maximum working pressure: inlet = 150 psi, back = 100 psi.

### Flow Indicator (F)

Machined cast acrylic, PVC connections, ceramic ball, PVDF ball stop, PVC half unions.

### Y Strainer (S)

PVC body, 1/32" Mesh

### Universal mounting blocks

PA 12

### Pump extended mounting brackets

316 Stainless Steel

### Skid mounting foot pads

316 Stainless Steel

### Mounting hardware

18-8 Stainless Steel

### Maximum working pressure

150 psig (10.3 bar)

### Operating Temperature

14°F to 115°F (-10°C to 46°C)

### Approximate Shipping Weight

Single Pump System

- Standard: 150 lb. (68 Kg)

- With Mounted Pump: 175 lb. (79 Kg)

Dual Pump System

- Standard: 200 lb. (90 Kg)

- With Mounted Pumps: 265 lbs (120 Kg)

### 3.0 Dimensions

Your Chem-Feed System may be designed differently from drawings below. However, the dimensions shown below remain the same no matter your configuration.

#### Single Pump System:

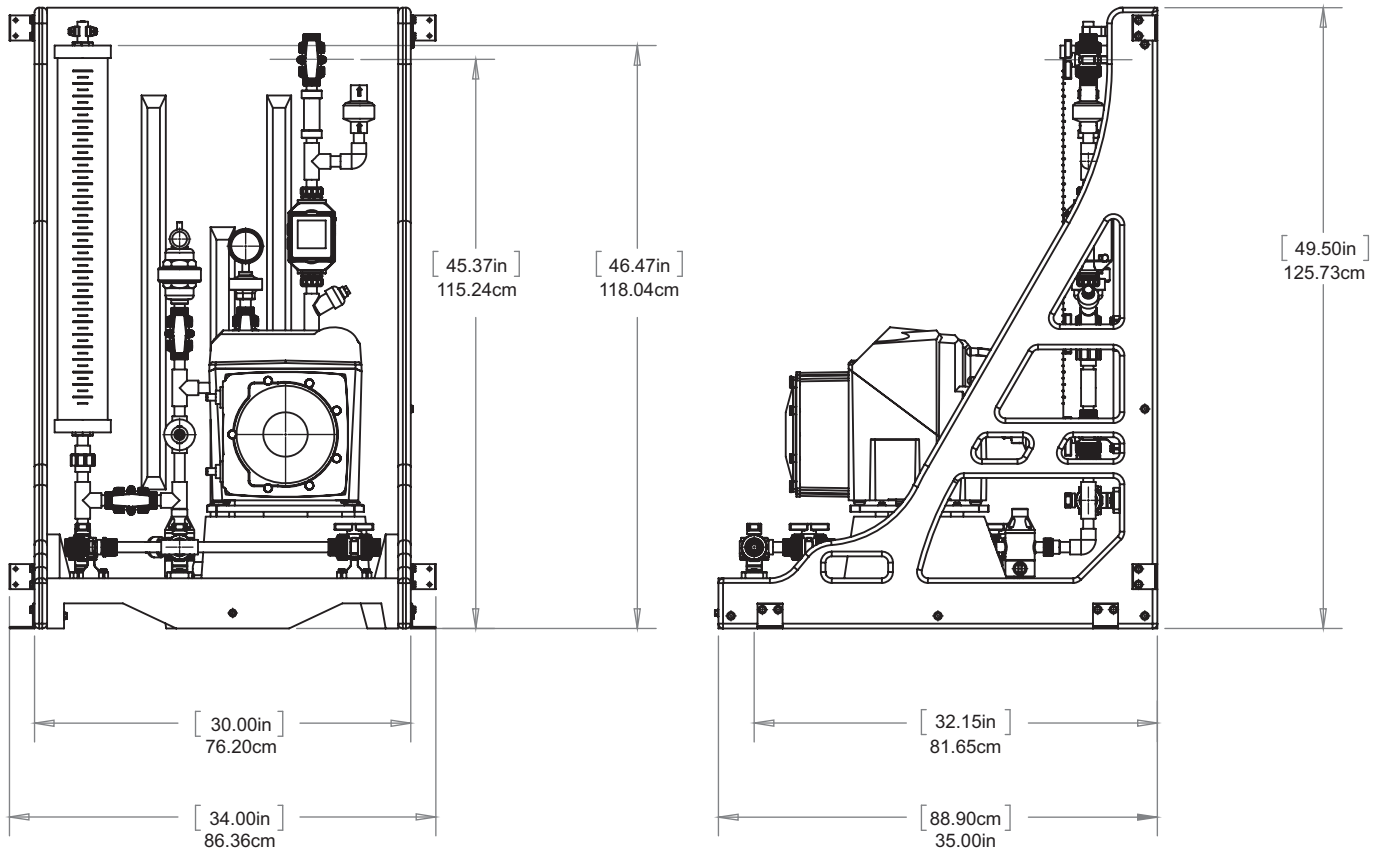

#### Dual Pump System:

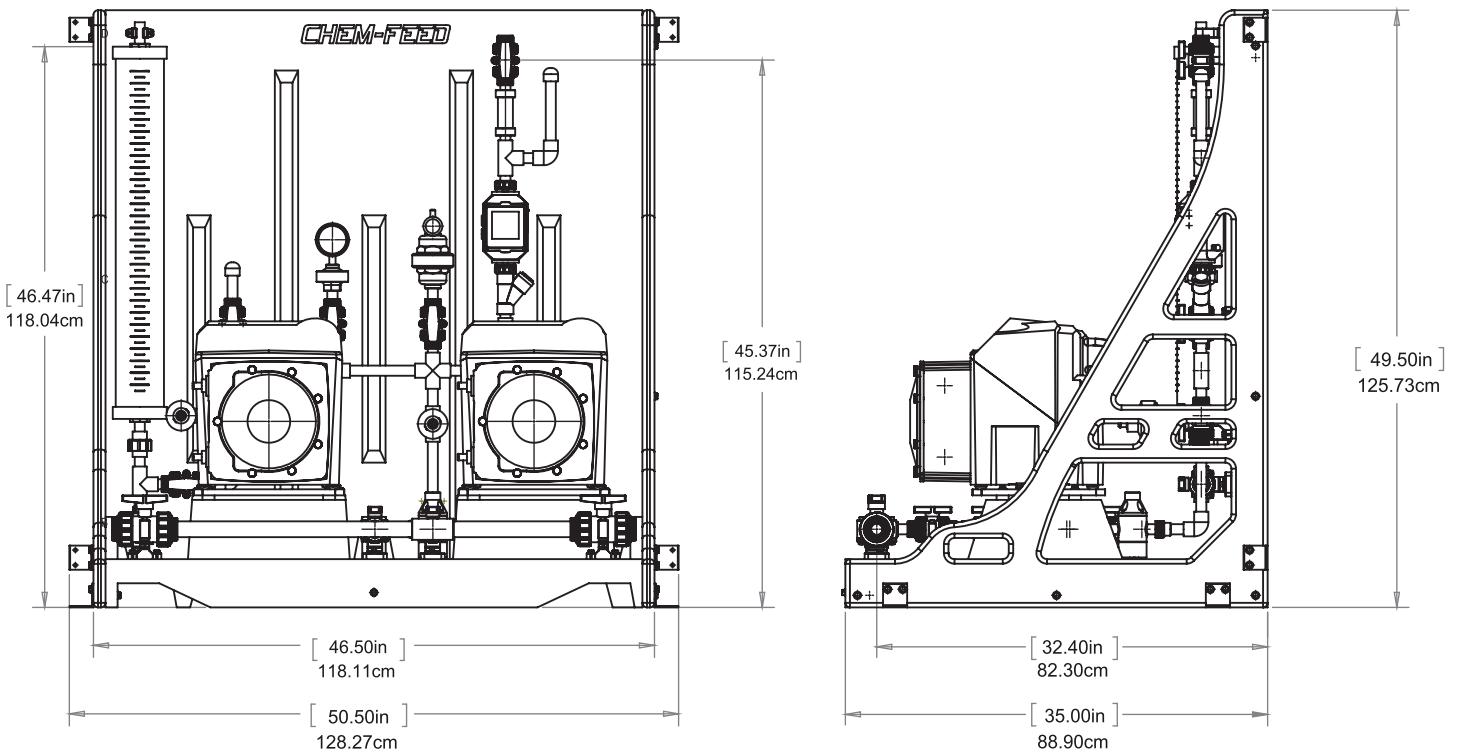

## 4.0 Features

**Chem-Feed® Engineered Skid Systems** were designed and engineered using solid modeling tools for superior piping installation and easy component maintenance. Custom engineered universal mounting blocks and pre-machined mounting slots provide for easy component servicing and replacement. Each factory built and tested system includes the following standard components:

- **Pressure Relief Valve** - Protects the system from over-pressurization, 5-150 psi setting range, 150 psi maximum system pressure. Ships on all systems.
- **Check Valve** - Protects the user from back-flow during pump maintenance. Ships on all systems.
- **Flow Verification Sensor** - S6A accurately verifies chemical feed. Exclusive to Blue-White®.
- **Inlet Y Strainer** - Protects system components from damage cause by dirt or debris.
- **Calibration Cylinder** - Confirm pump output under system conditions. Specify cylinder volumes from 1.6 GPH to 64 GPH.
- **Pulsation Dampener** - Protect the system components from pulsation. Recommended for diaphragm pump systems. Not recommended for peristaltic pump systems.
- **Pressure Gage with Guard** - Isolate and protect the system pressure gage. Specify pressure ranges from 0-100psi, or 0-200 psi.
- **Mounting Pads** - Stainless Steel mounting pads to secure Chem-Feed® System to a solid surface. Designed for floor mount or wall mount.
- **Corrosion Resistant** - Chem-Feed® frame constructed of chemically resistant polyethylene.

### 5.0 Chem-Feed® Skid System Matrix

Chem-Feed® Engineered Plastic Skid System Matrix										
<b>System type</b>										
CFPS-1	Single pump system - single chemical / single outlet, PE structure									
CFPS-2	Dual pump system - single chemical / single outlet, PE structure									
<b>Piping / Valves / Unions / Seal Materials</b>										
A	PVC piping, 1/2" OD PVC braided tubing connections									
B	CPVC piping, 1/2" OD PVC braided tubing connections									
C	PVC piping, 1/4" OD Polyethylene tubing connections									
D	CPVC piping, 1/4" OD Polyethylene tubing connections									
X	Skid Frame only without piping									
<b>Seal Material</b>										
V	FKM									
E	EPDM									
<b>Calibration Cylinder</b>										
A	64 GPH (4000 ml)									
B	32 GPH (2000 ml)									
C	16 GPH (1000 ml)									
D	8 GPH (500 ml)									
E	4 GPH (250 ml)									
F	1.6 GPH (100 ml)									
X	None									
<b>Pulsation Dampener</b>										
A	10 cubic inch, CPVC body, PTFE diaphragm									
X	None									
<b>Pressure Gauge w/Guard</b>										
A	200 PSI gauge with guard, PTFE diaphragm									
B	100 PSI gauge with guard, PTFE diaphragm									
C	30 PSI gauge with guard, PTFE diaphragm									
X	None									
<b>Chemical Feed Flowmeter</b>										
C	Model S6A12 Chemical Feed Flowmeter, 10-5,000 ml/min (0.158 - 79.2 GPH)									
D	Model S6A22 Chemical Feed Flowmeter, 100-10,000 ml/min (1.58 - 158 GPH)									
X	Inlet Strainer only									
<b>Miscellaneous Options - (leave blank if not specified)</b>										
1	Install with and ship with a specific pump model									
2	Perform pressure and fluid testing with a specific pump model									
3	Perform pressure, fluid testing, and ship with pump model installed									
CFPS-1	A	V	-	A	A	C	X	-	3	Sample Chem-Feed Engineered Skid System Part Number

### 6.0 Mounting Pump to the Chem-Feed® System - Single and Dual System

Socket Head  
Screw, SS #10-32 - .625"  
#10 washer, and 10-32 nut.  
(Qty: 4 of each per pump)

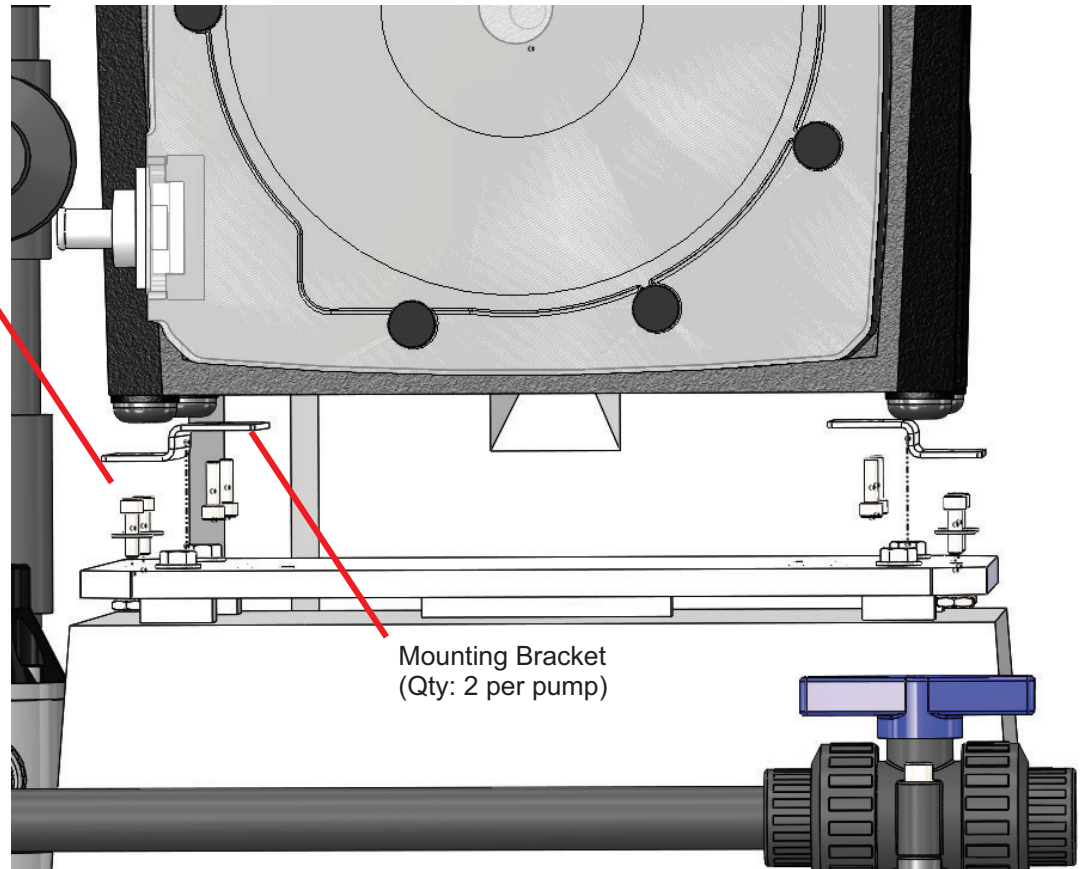

Mounting Bracket  
(Qty: 2 per pump)

### 7.0 Component Identification and Typical Operation - Single Pump Skid

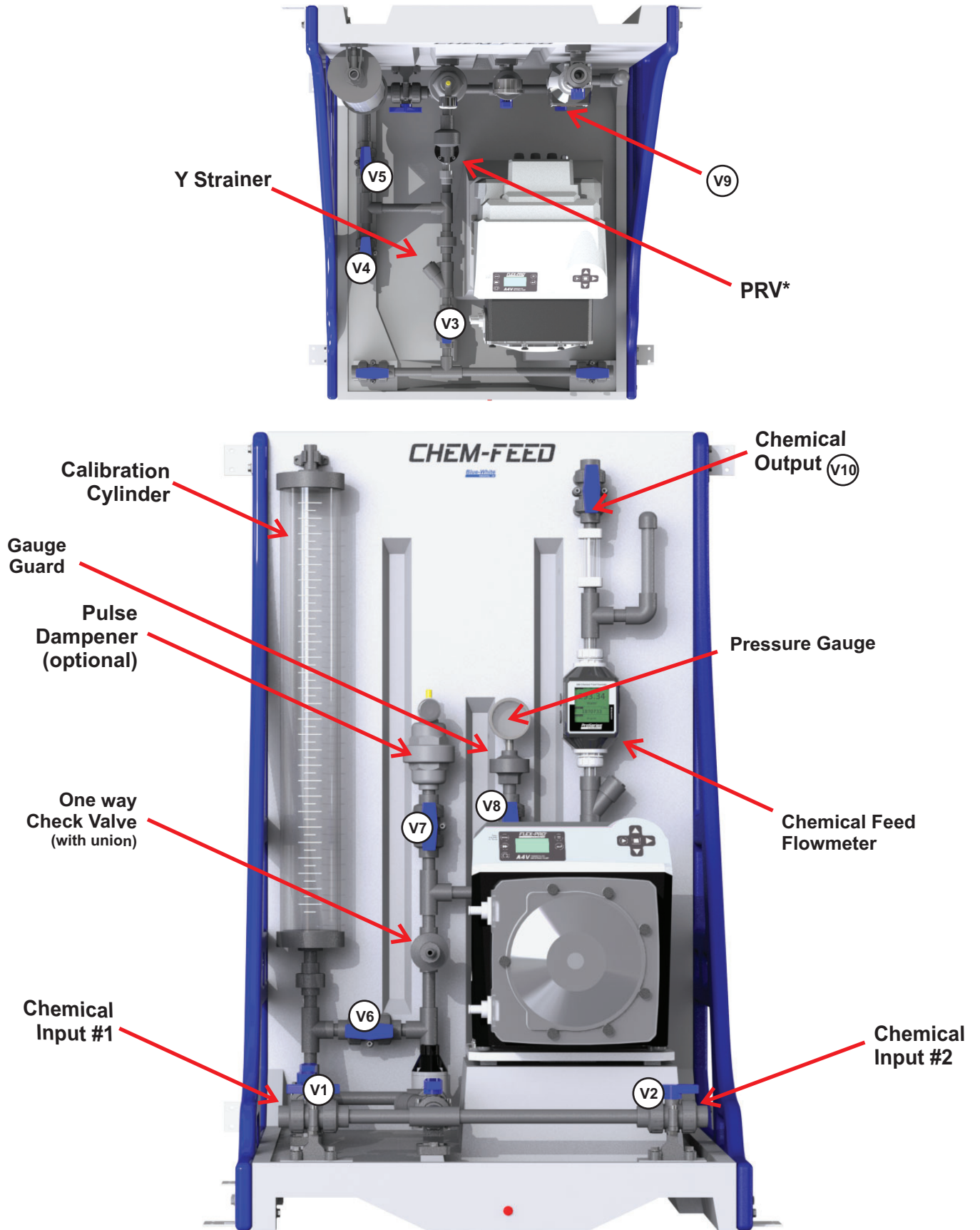

\* PRV = Pressure Relief Valve preset at 50psi



## 7.1 How To Operate the Chem-Feed® Skid System - Single Pump Skid

### Connections:

- Connect chemical solution into either Inlet 1 or inlet 2. (V-1 or V-2)
- Connect chemical treated system to outlet. (V-10)

### To Pump chemical solution into system.

- Open ball valve V-1 or V-2, depending on your inlet side.
- Open ball valve V-3 and V-4.
- Close ball valve V-5, V-6, and V-9.
- Open ball valve V-10 to inject chemical solution into your system.
- Start pump.

### To calibrate pump / system.

- Open ball valve V-1 or V-2, depending on your inlet side.
- Open ball valve V-3, V-4 , and V-6.
- Close ball valve V-5, V-9, and V-10.
- Start pump and run until calibration cylinder is filled to top calibration line. Do not leave pump unattended during this operation.
- Stop pump once calibration cylinder is filled.
- Close ball valves V-1, V-2, and V-6.
- Open ball valve V-5 and V-10 to inject chemical solution into your system.
- Note the chemical solution level in the calibration cylinder.
- To calibrate pump at maximum speed into your system, Press the prime button on pump. The prime mode runs the pump at maximum speed for 60 seconds (1 minute) on all Blue-White® ProSeries pumps.
- To calibrate pump at your desired feed rate, you must pre-program your pump speed before running this routine. Please refer to the instruction manual for your pump to adjust feed rate and additional calibration instructions.

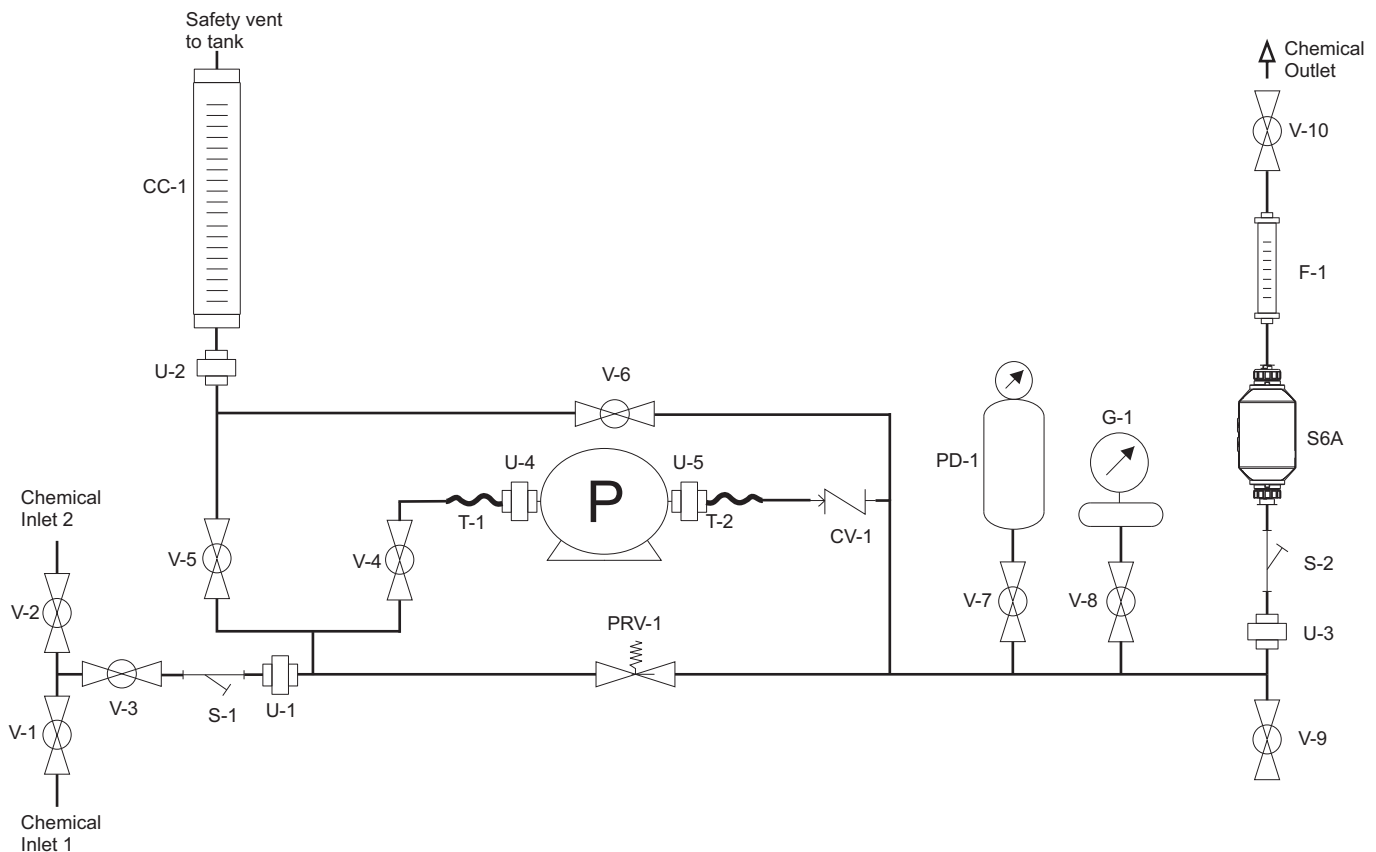

### 8.0 Component Identification and Typical Operation - Dual Pump Skid

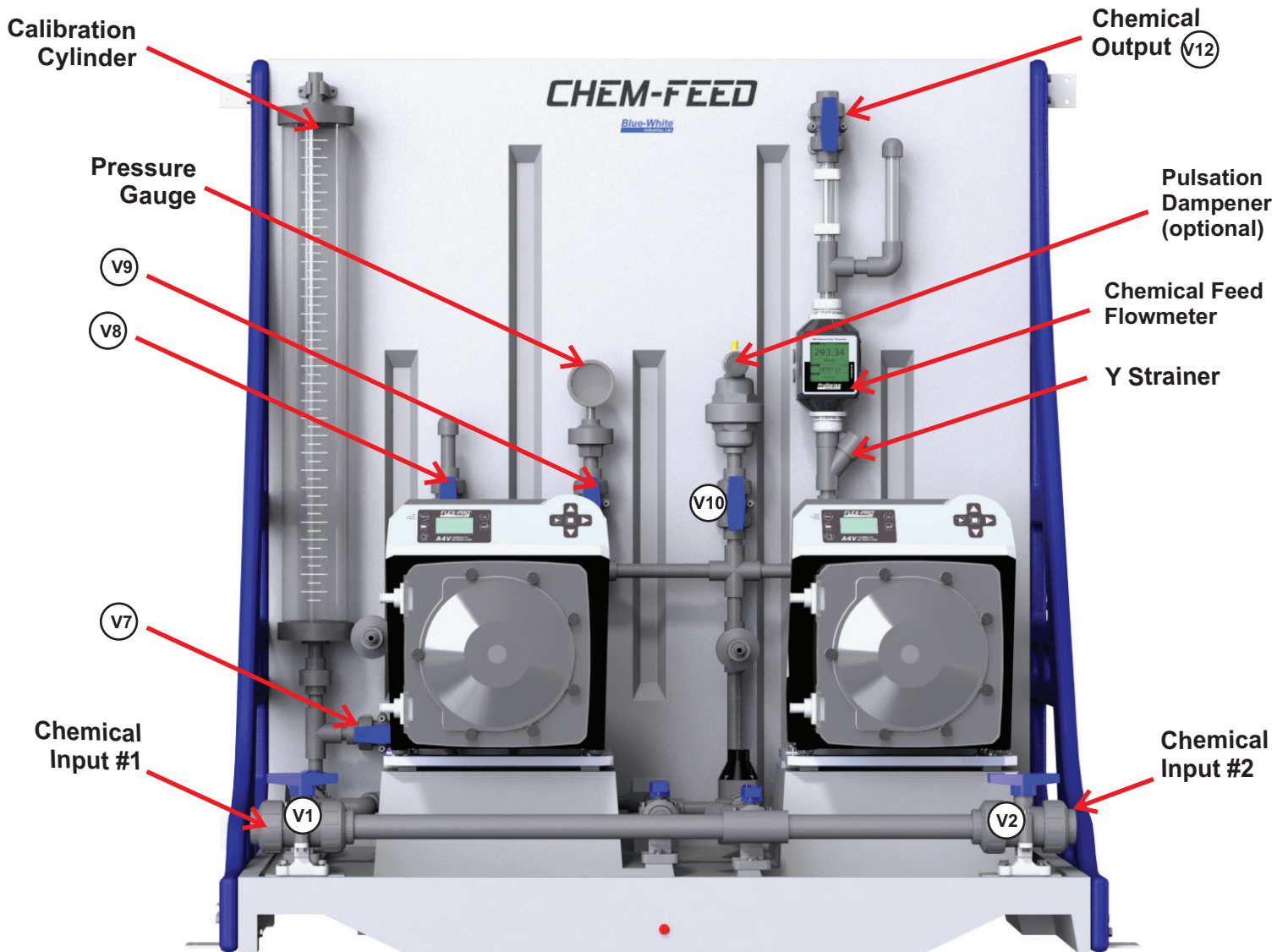
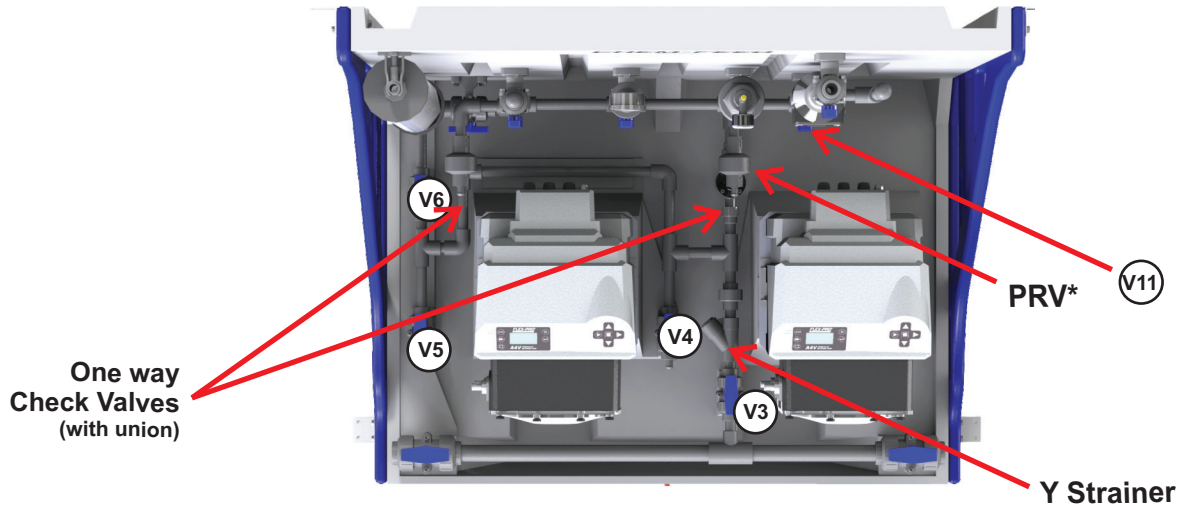

\* PRV = Pressure Relief Valve preset at 50psi

## 8.1 How To Operate the Chem-Feed® Skid System - Dual Pump Skid

### Connections:

- Connect chemical solution into either Inlet 1 or inlet 2. (V-1 or V-2)
- Connect chemical treated system to outlet. (V-11)

### To Pump chemical solution into system.

- Open ball valve V-1 or V-2, depending on your inlet side.
- Open ball valve V-3
- Close ball valve V-6, V-7, and V-11.
- Open ball valve V-4 and / or V5. Depending on your system design.
- Open ball valve V-12 to inject chemical solution into your system.
- Start pump(s).

### To calibrate pump(s) / system.

- Open ball valve V-1 or V-2, depending on your inlet side.
- Open ball valve V-3.
- Open ball valve V-4 or V5, depending on which pump you're calibrating.
- Close ball valve V-6, V-11, and V-12.
- Open ball valve V-7. This open valve will direct chemical into calibration cylinder.
- Start pump and run until calibration cylinder is filled to top calibration line. Do not leave pump unattended during this operation!
- Stop pump once calibration cylinder is filled.
- Close ball valves V-1, V-2, and V-7.
- Open ball valve V-4 or V-5, depending on which pump you're calibrating.
- Open ball valve V-6 and V-12 to inject chemical solution into your system.
- Note the chemical solution level in the calibration cylinder.
- To calibrate pump at maximum speed into your system, Press the prime button on pump. The prime mode runs the pump at maximum speed for 60 seconds (1 minute) on all Blue-White® ProSeries pumps.
- To calibrate pump at your desired feed rate, you must pre-program your pump speed before running this routine. Please refer to the instruction manual for your pump to adjust feed rate and additional calibration instructions.

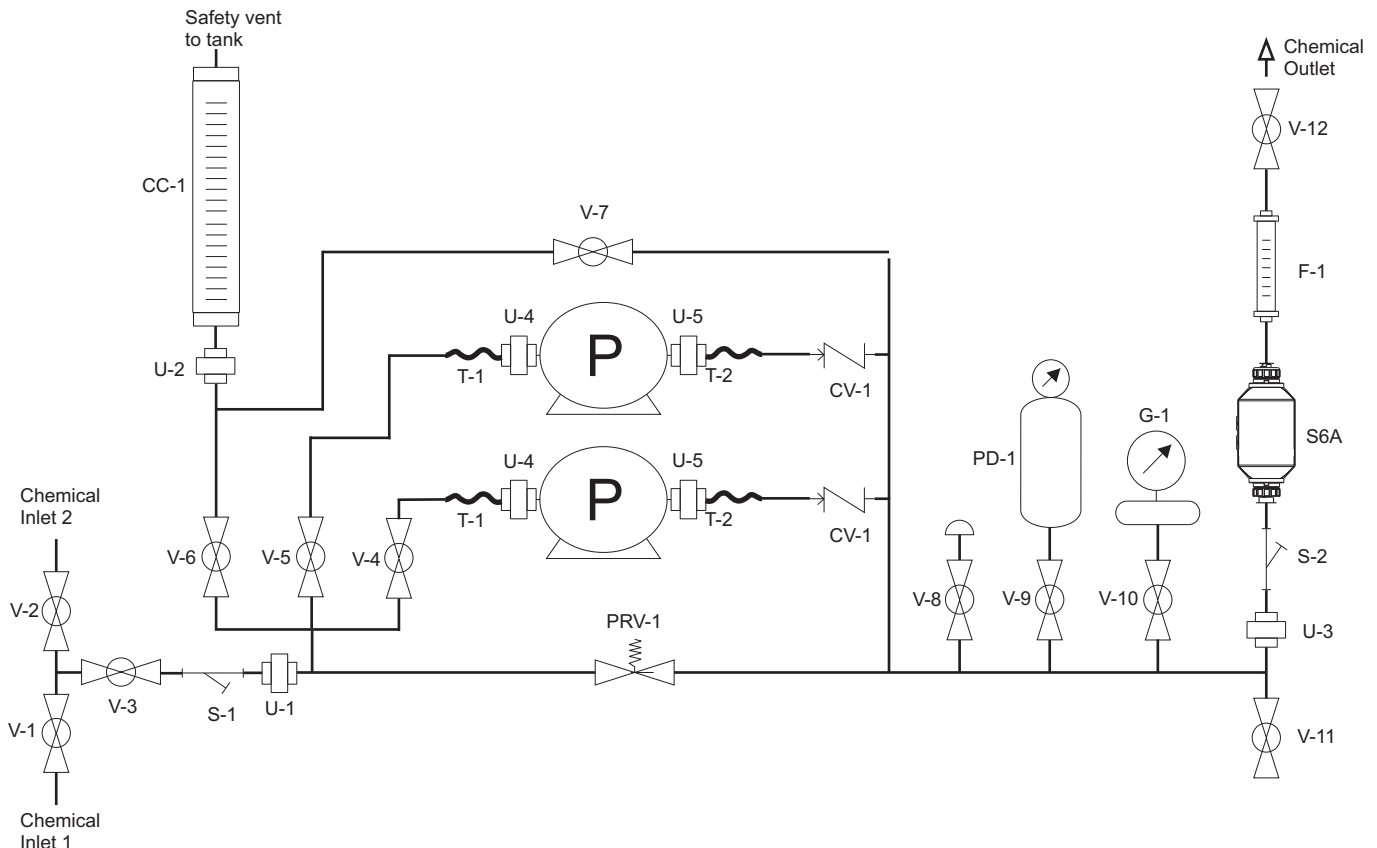

**LIMITED WARRANTY**

Your new Chem-Feed Engineered Skid System is a quality product and is warranted for 24 months from date of purchase (proof of purchase is required). The system will be repaired or replaced at our discretion. The metering pump may have its own warranty and is not covered under this warranty.

**WHAT IS NOT COVERED**

- **The metering pump is covered under a separate warranty.**
- **Removal, re-installation, and any related labor charges.**
- **Freight to the factory, or ProSeries service center.**
- **Systems that have been tampered with, or in pieces.**
- **Damage to the System that results from misuse, carelessness such as chemical spills, abuse, lack of maintenance, unsuitable materials of construction, or alteration which is out of our control.**
- **Systems damaged by acts of nature.**

Blue-White Industries does not assume responsibility for any loss, damage, or expense directly or indirectly related to or arising out of the use of its products. Failure must have occurred due to defect in material or workmanship and not as a result of operation of the product other than in normal operation as defined in the system manual. System components not manufactured by Blue-White are warranted by their respective manufacturers. Manufacturer makes no warranty of fitness or merchantability. Purchaser assumes all liability in determining the acceptability of the system in their specific application.

Warranty status is determined by the system serial label and the sales invoice or receipt. The serial label must be on the system and legible. The warranty status of the system will be verified by Blue-White or a factory authorized service center.

**OTHER IMPORTANT WARRANTY INFORMATION**

Blue-White engineered skid systems are factory tested with water only for pressure and performance. Installers and operators of these systems must be well informed and aware of the precautions to be taken when injecting various chemicals - especially those considered hazardous or dangerous. Eye protection must be worn when working around this product.

Should it become necessary to return the system or system components for repair or service, you must attach information regarding the chemical used as some residue may be present within the unit which could be a hazard to service personnel. Blue-White Industries will not be liable for any damage that may result by the use of chemicals with their system and its components.

**PROCEDURE FOR IN WARRANTY REPAIR**

Contact the factory to obtain a RMA (Return Material Authorization) number. Carefully pack the system or component to be repaired. Please enclose a brief description of the problem as well as the original invoice or sales receipt, or copy showing the date of purchase. Prepay all shipping costs. COD shipments will not be accepted. Warranty service must be performed by the factory or an authorized ProSeries service center. Damage caused by improper packaging is the responsibility of the sender. When In-Warranty repair or replacement is completed, the factory pays for return shipping to the dealer or customer.



Users of electrical and electronic equipment (EEE) with the WEEE marking per Annex IV of the WEEE Directive must not dispose of end of life EEE as unsorted municipal waste, but use the collection framework available to them for the return, recycle, recovery of WEEE and minimize any potential effects of EEE on the environment and human health due to the presence of hazardous substances. The WEEE marking applies only to countries within the European Union (EU) and Norway. Appliances are labeled in accordance with European Directive 2002/96/EC. Contact your local waste recovery agency for a *Designated Collection Facility* in your area.

**ProSeries®**  
by Blue-White Ind.

5300 Business Drive, Huntington Beach, CA 92649 USA

Phone: 714-893-8529 FAX: 714-894-9492

E mail: sales@blue-white.com or techsupport@blue-white.com URL: www.blue-white.com