

SEE DRAWING #2
FOR DETAILS

FILTER DATA (FOR EACH FILTER)	
TOTAL SURFACE AREA:	1.71 SQ.FT.
MAX WORKING PRESSURE:	58 PSI
MAX FLOW RATE:	20 GPM/SQ.FT.
ESTIMATED MEDIA AMOUNTS	
SAND:	180 LBS.
GRAVEL:	LBS.
WEIGHTS (APPROXIMATE)	
FILTER SHIPPING WEIGHT:	22 LBS.
FILTER OPERATING WEIGHT:	440 LBS.

GENERAL NOTES:

1. MEDIA NOT INCLUDED WITH FILTER.
2. CONCRETE SLAB TO BE DESIGNED BY OTHERS.
3. DRAWING MAY INCLUDE ITEMS SHOWN WHICH ARE NOT BEING SUPPLIED BY WATERCO. PLEASE REFER TO QUOTE FOR LIST OF ITEMS SUPPLIED.
4. FILTER MADE FROM HIGH STRENGTH FIBERGLASS AND RESINS.
5. ALL INTERNAL FILTER COMPONENTS CONSTRUCTED OF SCHEDULE 80 PVC.

DATE: ___/___/2020	DATE: ___/___/2020
CUSTOMER:	ENG: JS
DATE: ___/___/2020	DATE: ___/___/2020
PROD. MGR.: PG	DRN BY: RWS, Jr.

		
EXOTUF SKS18D SKID PACK WITH E450 FILTER, 1-1/2" MPV, & 1-1/2 HP SUPAMITE PUMP		
DRAWING TITLE:	SHEET:	REV:
SKID PACKS SKS-16-18-20-24	1 OF 2	0
SCALE:	DATE:	CUSTOMER:
1:12	3/5/2020	

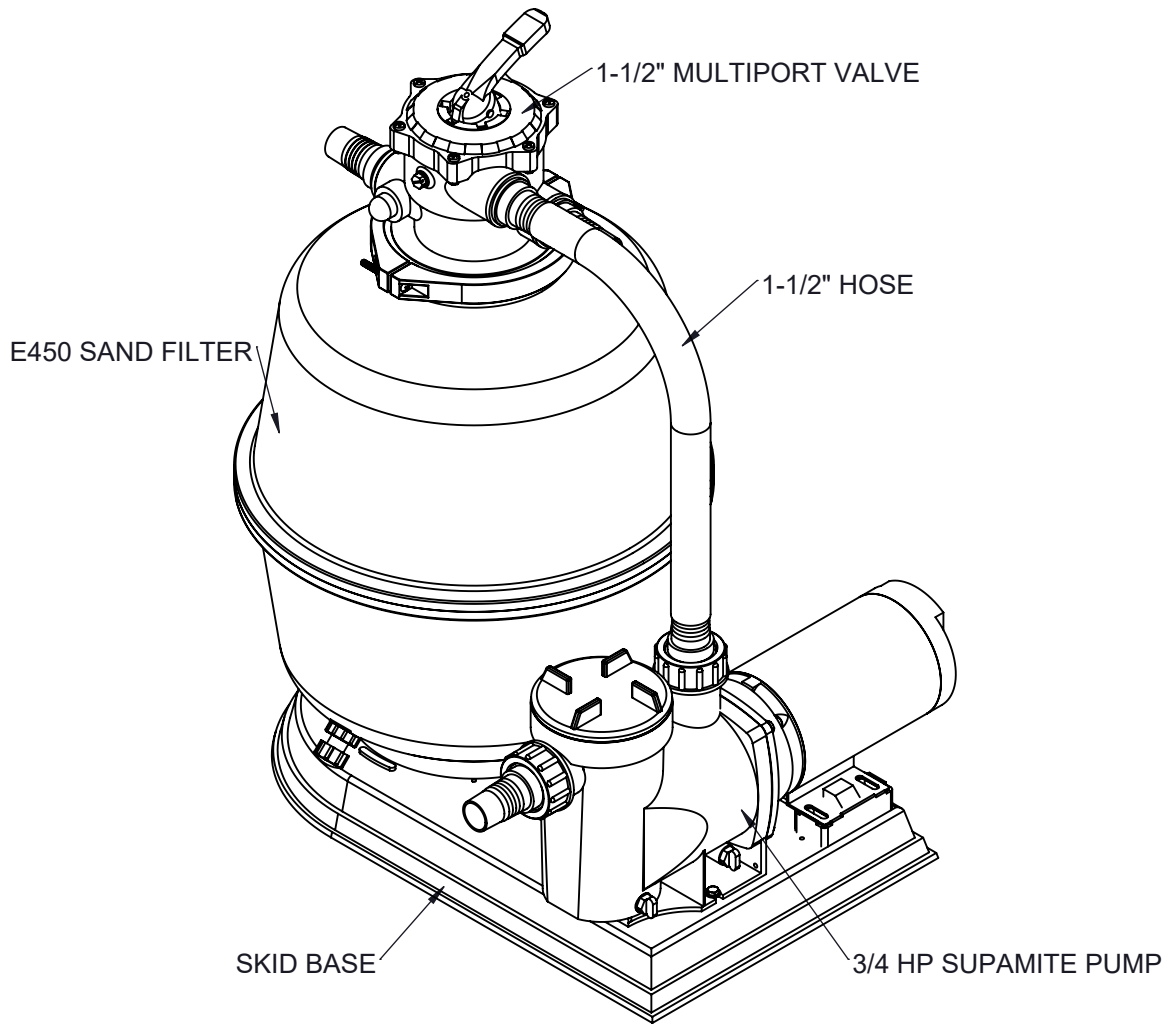

FILTER DATA (FOR EACH FILTER)		GENERAL NOTES:		DATE: ___/___/2020		DATE: ___/___/2020		WATERCO	
TOTAL SURFACE AREA:	1.71 SQ.FT.	1. MEDIA NOT INCLUDED WITH FILTER. 2. CONCRETE SLAB TO BE DESIGNED BY OTHERS. 3. DRAWING MAY INCLUDE ITEMS SHOWN WHICH ARE NOT BEING SUPPLIED BY WATERCO. PLEASE REFER TO QUOTE FOR LIST OF ITEMS SUPPLIED. 4. FILTER MADE FROM HIGH STRENGTH FIBERGLASS AND RESINS. 5. ALL INTERNAL FILTER COMPONENTS CONSTRUCTED OF SCHEDULE 80 PVC.		CUSTOMER:	ENG: JS	EXOTUF SKS18D SKID PACK WITH E450 FILTER, 1-1/2" MPV, & 1-1/2 HP SUPAMITE PUMP			
MAX WORKING PRESSURE:	58 PSI			DATE: ___/___/2020	DATE: ___/___/2020				
MAX FLOW RATE:	20 GPM/SQ.FT			PROD. MGR.: PG	DRN BY: RWS, Jr.	DRAWING TITLE: SKID PACKS SKS-16-18-20-24		SHEET: 1 OF 2	REV: 0
ESTIMATED MEDIA AMOUNTS				SCALE: 1:12		DATE: 3/5/2020		CUSTOMER:	
SAND:	180 LBS.								
GRAVEL:	LBS.								
WEIGHTS (APPROXIMATE)									
FILTER SHIPPING WEIGHT:	22 LBS.								
FILTER OPERATING WEIGHT:	440 LBS.								