

SEE SHEET #2  
FOR DETAILS

<b>FILTER DATA (FOR EACH FILTER)</b> TOTAL SURFACE AREA: 3.05 SQ.FT. MAX WORKING PRESSURE: 58 PSI MAX FLOW RATE: 20 GPM/SQ.FT. <b>ESTIMATED MEDIA AMOUNTS</b> SAND: 310 LBS. GRAVEL: LBS. <b>WEIGHTS (APPROXIMATE)</b> FILTER SHIPPING WEIGHT: 33 LBS. FILTER OPERATING WEIGHT: 725 LBS.		<b>GENERAL NOTES:</b> 1. MEDIA NOT INCLUDED WITH FILTER. 2. CONCRETE SLAB TO BE DESIGNED BY OTHERS. 3. DRAWING MAY INCLUDE ITEMS SHOWN WHICH ARE NOT BEING SUPPLIED BY WATERCO. PLEASE REFER TO QUOTE FOR LIST OF ITEMS SUPPLIED. 4. FILTER MADE FROM HIGH STRENGTH FIBERGLASS AND RESINS. 5. ALL INTERNAL FILTER COMPONENTS CONSTRUCTED OF SCHEDULE 80 PVC.		DATE: ___/___/2020 CUSTOMER:	DATE: ___/___/2020 ENG: JS	 <b>EXOTUF SKS24C SKID PACK</b> WITH E600 FILTER, 1-1/2" MPV, & 1 HP SUPAMITE PUMP	DRAWING TITLE: SKID PACKS SKS-16-18-20-24	SHEET: 1 OF 2	REV: 0
		DATE: ___/___/2020 PROD. MGR.: PG	DATE: ___/___/2020 DRN BY: RWS, Jr.	SCALE: 1:12      DATE: 3/5/2020      CUSTOMER:					

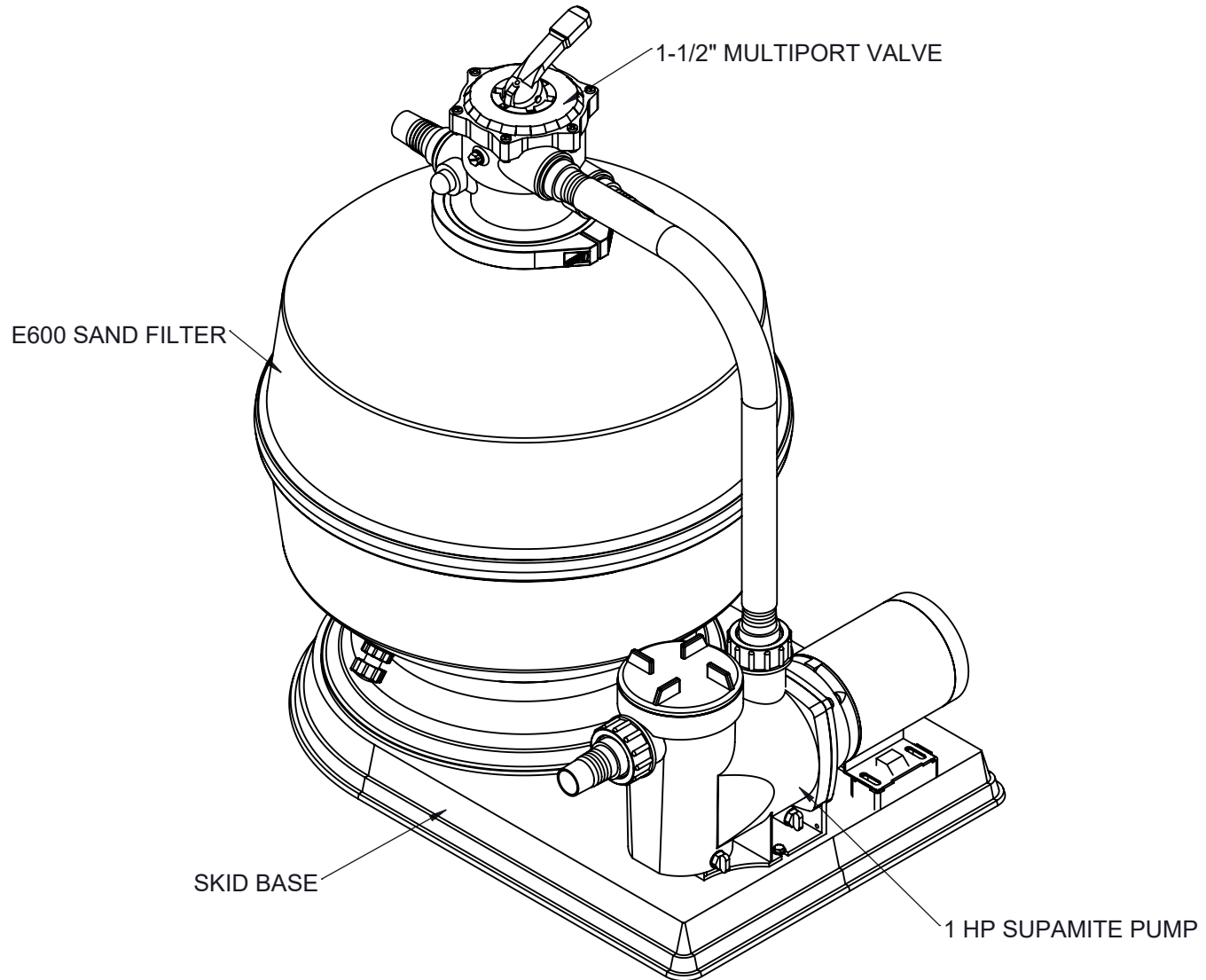

<b>FILTER DATA (FOR EACH FILTER)</b>	
TOTAL SURFACE AREA:	3.05 SQ.FT.
MAX WORKING PRESSURE:	58 PSI
MAX FLOW RATE:	20 GPM/SQ.FT
<b>ESTIMATED MEDIA AMOUNTS</b>	
SAND:	310 LBS.
GRAVEL:	LBS.
<b>WEIGHTS (APPROXIMATE)</b>	
FILTER SHIPPING WEIGHT:	33 LBS.
FILTER OPERATING WEIGHT:	725 LBS.

**GENERAL NOTES:**

1. MEDIA NOT INCLUDED WITH FILTER.
2. CONCRETE SLAB TO BE DESIGNED BY OTHERS.
3. DRAWING MAY INCLUDE ITEMS SHOWN WHICH ARE NOT BEING SUPPLIED BY WATERCO. PLEASE REFER TO QUOTE FOR LIST OF ITEMS SUPPLIED.
4. FILTER MADE FROM HIGH STRENGTH FIBERGLASS AND RESINS.
5. ALL INTERNAL FILTER COMPONENTS CONSTRUCTED OF SCHEDULE 80 PVC.

DATE: ___/___/2020	DATE: ___/___/2020
CUSTOMER:	ENG: JS
DATE: ___/___/2020	DATE: ___/___/2020
PROD. MGR.: PG	DRN BY: RWS, Jr.



**EXOTUF SKS24C SKID PACK  
WITH E600 FILTER, 1-1/2" MPV,  
& 1 HP SUPAMITE PUMP**

DRAWING TITLE: SKID PACKS SKS-16-18-20-24		SHEET: 2 OF 2	REV: 0
SCALE: NTS	DATE: 3/5/2020	CUSTOMER:	