



INSTALLATION INSTRUCTIONS

MODEL #89973 VERTICAL DOOR PANTRY INSERT MANUAL

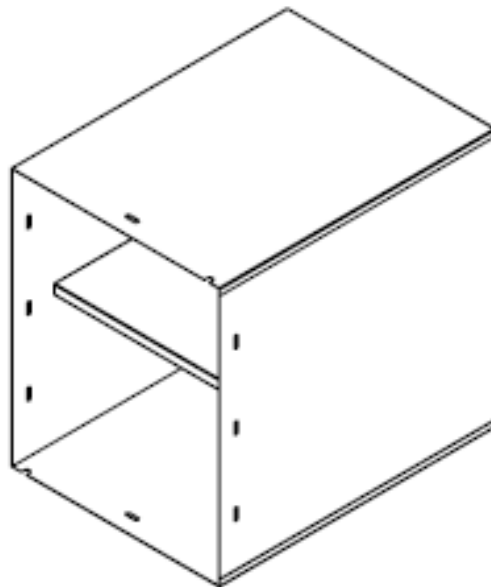



TABLE OF CONTENTS

PAGE

INSTALLATION INSTRUCTIONS.....	2
<i>CABINET LOCATION GUIDELINES</i>	2
REGULAR MAINTENANCE.....	4
<i>CLEANING THE UNIT</i>	4
1 YEAR LIMITED WARRANTY.....	5
<i>REGISTERING YOUR PANTRY INSERT</i>	5

- READ THE FOLLOWING INSTRUCTIONS CAREFULLY AND BE SURE YOUR PANTRY INSERT IS PROPERLY INSTALLED, ASSEMBLED AND CARED FOR. FAILURE TO FOLLOW THESE INSTRUCTIONS MAY RESULT IN SERIOUS BODILY INJURY AND/OR PROPERTY DAMAGE. IF YOU HAVE QUESTIONS CONCERNING ASSEMBLY OR OPERATION, CONSULT YOUR DEALER OR APPLIANCE SERVICE REPRESENTATIVE.

- NOTE TO INSTALLER:

LEAVE THESE INSTRUCTIONS WITH THE CONSUMER AFTER INSTALLATION.

- NOTE TO THE CONSUMER:

RETAIN THESE INSTRUCTIONS FOR FUTURE REFERENCE.

*FOR WARRANTY PURPOSES, PLEASE RECORD YOUR SERIAL NUMBER, DATE OF PURCHASE & A COPY OF YOUR RECEIPT OR INVOICE IN THE BACK OF YOUR MANUAL ON PAGE 5.



READ CAREFULLY BEFORE INSTALLATION OF VERTICAL DOOR PANTRY INSERT

BULL

INSTALLATION INSTRUCTIONS

Your Vertical Door Pantry Insert comes to you fully assembled. We strongly recommend professional installation. These instructions will provide you with the measurements necessary for you or your builder to construct a masonry structure to house your double door pantry insert.

NOTE TO INSTALLER: Leave these instructions with the consumer for future reference. The double door pantry insert must be installed in accordance with all local building codes.

CABINET LOCATION GUIDELINES

- Install the unit in a dry, well-ventilated area.
 - Unit should be away from direct sunlight; extreme cold ambient temperatures may also cause the unit not to perform properly.
- Avoid installation in a high humidity and/or dusty area.
 - Humidity could cause unit to rust and decrease efficiency of the unit.
 - Dust collected on condenser coil will cause unit to malfunction. Clean the condenser at least once a month with a brush or clean cloth.

INSTALLING SINGLE DOOR ONTO PANTRY INSERT

Step 1: Slide vertical door onto pantry insert, lining up the mounting holes.

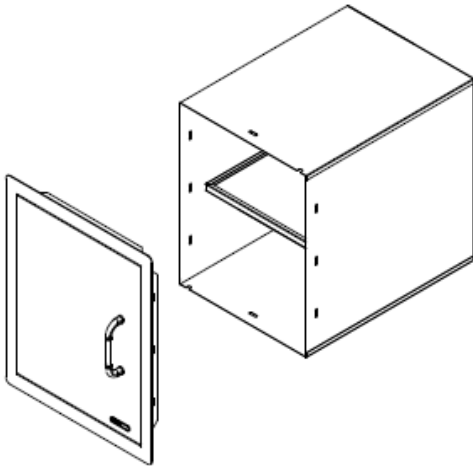

Step 2: Insert hardware into mounting holes and tighten.

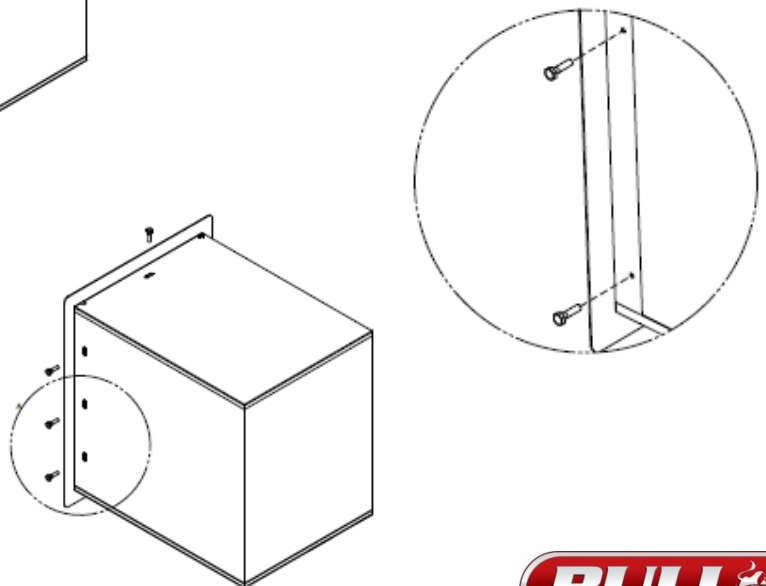

BULL



INSTALLATION INSTRUCTIONS (cont.)

INSTALLING PANTRY INSERT INTO ISLAND

Step 1: Slide assembled pantry insert into island cutout.

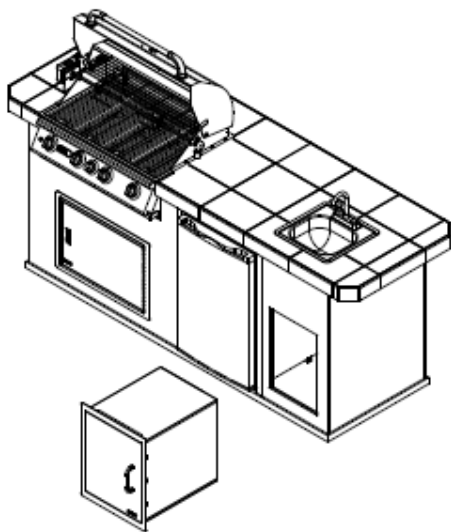

2. Fasten sides of assembled pantry insert to vertical studs inside island.

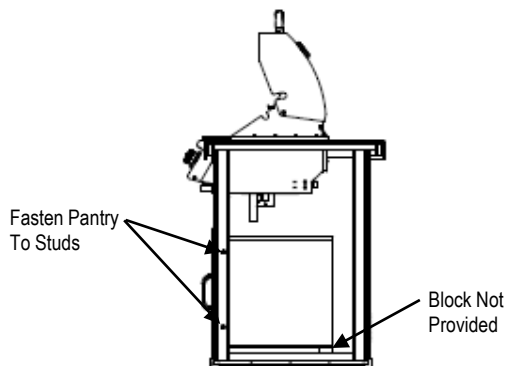

NOTE: Support the back end of your pantry insert with a 1 1/4" x 2 1/2" x 30" block. Too much weight inside the pantry insert will cause it to bow and bend. Block **NOT** provided.



REGULAR MAINTENANCE

CLEAING THE PANTRY INSERT

Two easy steps to help you clean your pantry insert:

- Make sure the pantry insert is cool to the touch. Proximity to the grill head can cause the walls of the pantry insert to absorb some heat.
- Wipe down the inside of the pantry insert with stainless steel cleaner.



1 YEAR LIMITED WARRANTY

REGISTERING YOUR VERTICAL DOOR PANTRY INSERT

In order to validate your Bull Limited Warranty, you must complete the Warranty Registration Card within 90 days from the Proof of Purchase. You may register your unit either online at www.bullbbq.com or by sending in the completed hard copy along with a copy of the Proof of Purchase to:

Product Registration
Bull Outdoor Products
2483 W Walnut Ave
Rialto, CA 92376

Bull Outdoor Products, Inc. warrants to the original purchaser at the original site of delivery with proof of purchase of each refrigerator that when subject to normal residential use, it is free from defects in workmanship and materials for the periods specified below. This warranty excludes pantry inserts used in rental or commercial applications. It does not cover labor or labor related charges. There will be a shipping and handling charge for the delivery of the warranty part(s).

Our obligation under this warranty is limited to repair or replacement, at our option, of the product during the warranty period. The extent of any liability of Bull Outdoor Products, Inc., under this warranty is limited to repair or replacement. This warranty does not cover normal wear of parts, damage resulting from any of the following: negligent use or misuse of the product, use contrary to operating instructions or alteration by any person other than our factory service center. The warranty period is not extended by such repair or replacement.

Warranty claim procedure: If you are filing a Warranty Claim, please visit our website at Bullbbq.com and complete a Warranty Claim Form. The claim form can be located under the Support Tab, then Grill Warranty Claim Form. All claims **MUST** be submitted through the form in order to be processed. If you need further assistance, you may contact our Warranty Service Center during the hours of 5:00am to 5:00pm P.S.T. Monday through Friday, except holidays, at (800) 521-2855.

Product repair as provided under this warranty is your exclusive remedy. Bull Outdoor Products, Inc. shall not be liable for any incidental or consequential damages for breach of any express or implied warranty on its products. Except to the extent prohibited by applicable law, any implied warranty or merchantability or fitness for a particular purpose on this product to the duration of the above warranty. Some states do not allow the exclusion or limitation of incidental or consequential damages, or allow limitations on how long an implied warranty lasts, so the above limitations or exclusions may not apply to you. This warranty gives you specific legal rights, and you may have other rights, which vary from state to state.

Model Number _____

Serial Number _____

Date of Purchase _____

Attach a copy of your receipt or invoice here

