



# ADJUSTABLE FLOW MULTI-NOZZLE DECK JET

CMP# 25597-3XX-000, 25598-3XX-000

PATENT # 8,366,016

- Determine the proper size of the main feed pipe:  
Use 1-1/2" pipe for up to 8 Deck Jets  
Use 2" pipe for up to 12 Deck Jets  
Use 2-1/2" pipe for up to 16 Deck Jets
- Install a ball valve on the main feed pipe near the pump to adjust the total water pressure delivered to the deck jets.
- Reduce the piping to 3/4" pipe. When installing more than one deck jet it is necessary to create an equal pressure loop to equalize the pressure in the line.
- The body is ABS plastic and designed to allow for 3/4" spigot plumbing with straight pipe or an elbow. Use only PVC/ABS glue to secure the pipe to the body. Also comes with an adapter which is 3/4" socket and 1/2" socket.
- Anchor the deck jet body and protective cover so that the top is level with the height of the finished deck. Use protective cover to protect deck jet while working on pool and laying deck.
- Remove protective cover, wrap the threaded plug with teflon tape, and install into the deck jet body. Be sure not to over tighten. Replace the protective cover. Leave the plug installed and keep the pipe pressurized during installation.
- Once the deck is finished, remove the protective cover and remove the plug. Turn on the pump, open the valves, and run water through the lines to remove any debris that may have collected.
- Take the jet nozzle housing assembly and install in the body by turning the installation tabs (hand tighten only - do not overtighten - see photo).

## PERFORMANCE GUIDE

Stream Distance in Feet

		2	3	4	5	6	7
FAN	GPM	--	1	1.2	1.3	1.5	1.9
	PSI	--	1.8	2.2	2.6	3.6	4.8
	SPREAD	--	12"	24"	36"	60"	96"
	HEIGHT	--	12"	18"	24"	36"	48"
TRIPLE STREAM	GPM	1.3	1.6	1.9	2.2	2.5	2.8
	PSI	2	2.5	3.5	4.2	5	6
	SPREAD	8"	12"	18"	20"	24"	30"
	HEIGHT	9"	14"	20"	24"	30"	36"
3/16" SINGLE	GPM	0.4	0.5	0.7	0.7	0.8	0.9
	PSI	1.5	2	2.4	2.8	3.2	3.6
	HEIGHT	10"	15"	21"	25"	31"	38"
1/4" SINGLE	GPM	1.2	1.5	1.8	2.0	2.2	2.5
	PSI	2	2.5	3.2	4	4.6	5.5
	HEIGHT	10"	16"	22"	27"	32"	40"
5/16" SINGLE	GPM	1.5	1.9	2.3	2.6	2.9	3.2
	PSI	2	2.8	3.8	4.5	5.4	6.2
	HEIGHT	6"	9"	14"	17"	20"	26"

- Adjust the position of the eyeball nozzle and adjust any valves in the line to achieve the desired flow. To balance the flow, the flow adjustment ring may be turned by hand (clockwise for less flow, counter-clockwise for more - see photo). Do not overtighten jet nozzle housing assembly when adjusting flow.
- If the stream is disrupted, remove the jet nozzle and check for debris.
- To winterize the deck jet, first remove the jet nozzle housing assembly. Next blow air through the lines, and install the plug.
- To change the eyeball nozzle, remove the retaining ring (see photo).

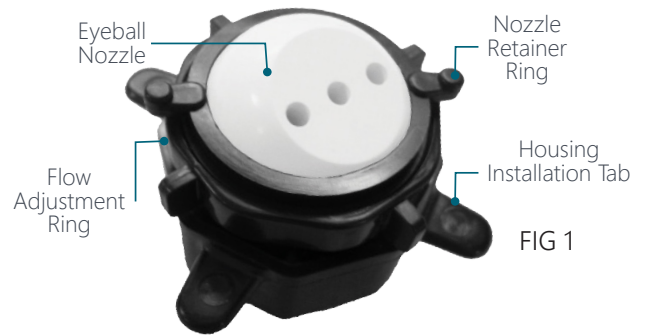

**TIP:** When adjusting multiple deck jets, keep in mind the water has to go somewhere. For example, if there are three deck jets and 2 have a five feet high stream and one has a nine feet high stream, turning down the nine feet high stream will make the other two more powerful. To make them all 5 feet high, the ball valve in the line would have to be adjusted.

# WARNING



This product is must be installed and serviced by a pool and spa professional. These instructions must be followed exactly to ensure proper function of the par

# Available Styles and Product Dimensions

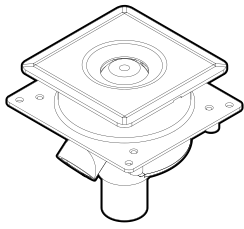

25598-300  
25598-301  
25598-309  
25598-343

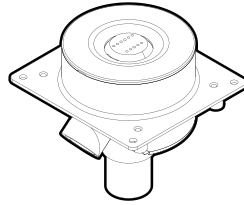

25597-333

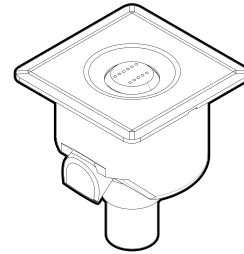

25598-353

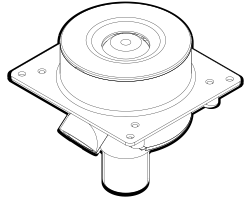

25597-300  
25597-301  
25597-309  
25597-342  
25597-343

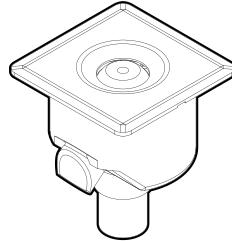

25598-310  
25598-311  
25598-319  
25598-363



25597-353

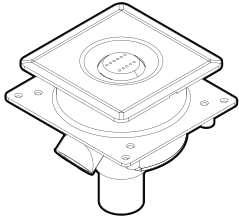

25598-333



25597-310  
25597-311  
25597-319  
25597-363

**TOP VIEW**

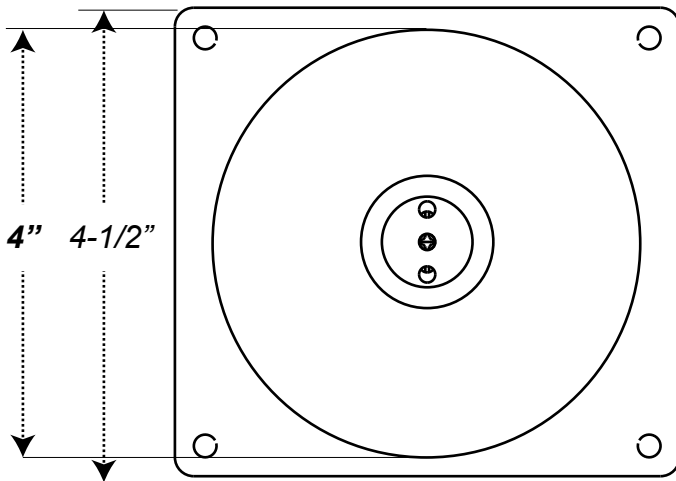

**SIDE VIEW**

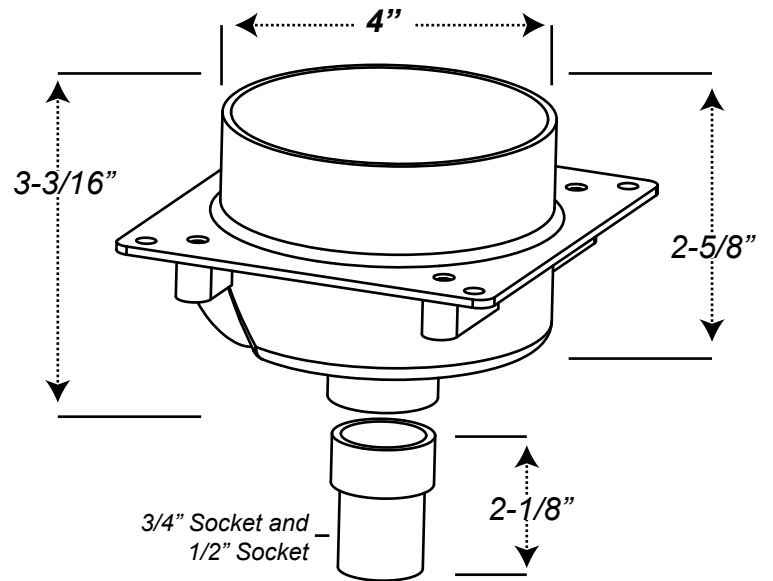

## WARNING



This product is must be installed and serviced by a pool and spa professional. These instructions must be followed exactly to ensure proper function of the par