

# PATRIOT-AT1 LIFT

U.S. PATENT NO'S: [7,249,386 B2] [D507,769 S]

\*MEASUREMENT TAKEN WITH THE LIFT AT FULL LOAD\*

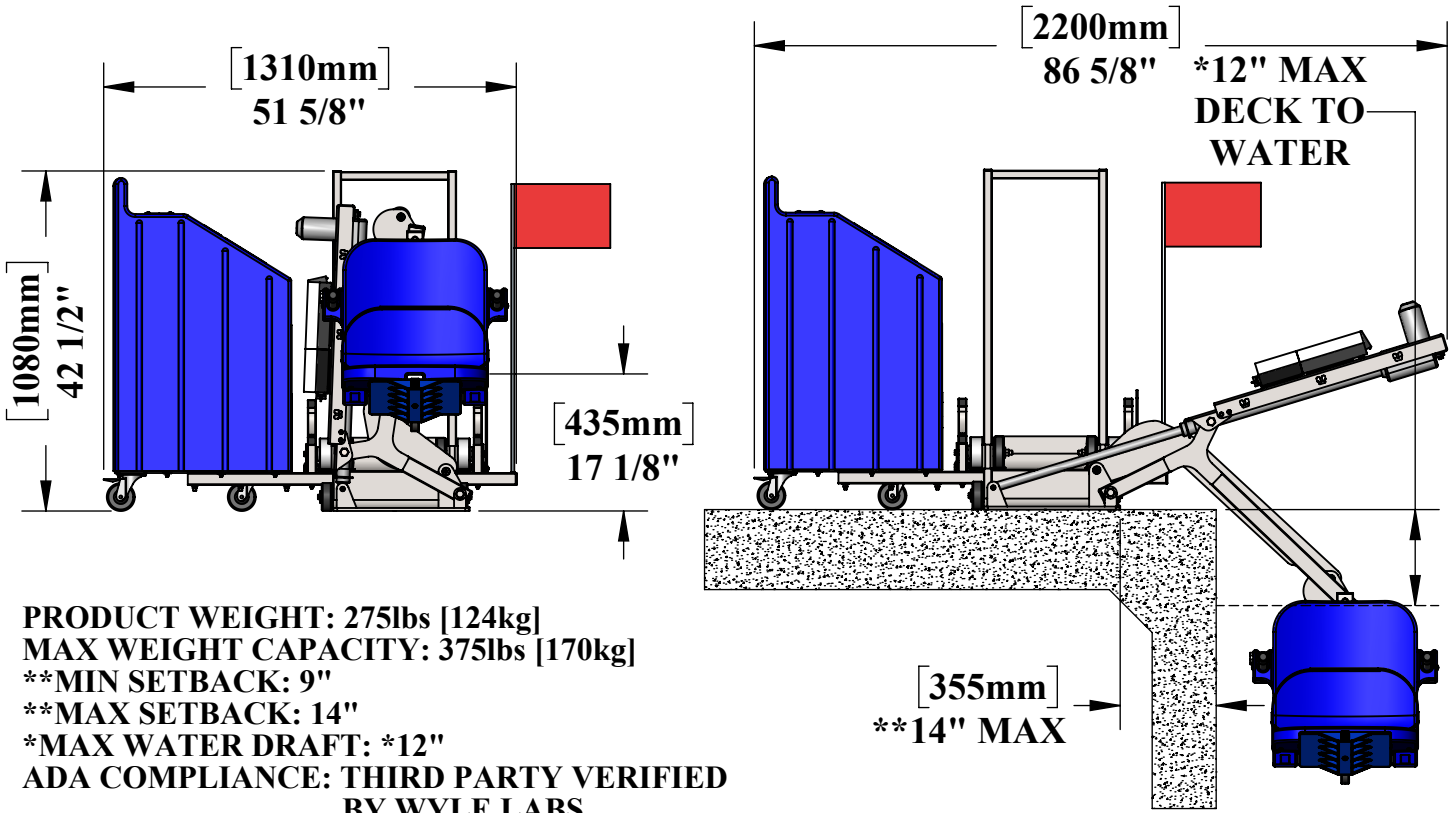

**PRODUCT WEIGHT:** 275lbs [124kg]  
**MAX WEIGHT CAPACITY:** 375lbs [170kg]  
**\*\*MIN SETBACK:** 9"  
**\*\*MAX SETBACK:** 14"  
**\*MAX WATER DRAFT:** \*12"  
**ADA COMPLIANCE: THIRD PARTY VERIFIED BY WYLE LABS**  
**STOWED WIDTH:** 35 1/4" (W/O FOOTREST)

Inspected And Verified To Meet  
 Applicable Sections of ADA  
 Guidelines Section 1009.2 By

**wyle**  
 laboratories

A Registered ISO 9001  
 Laboratory

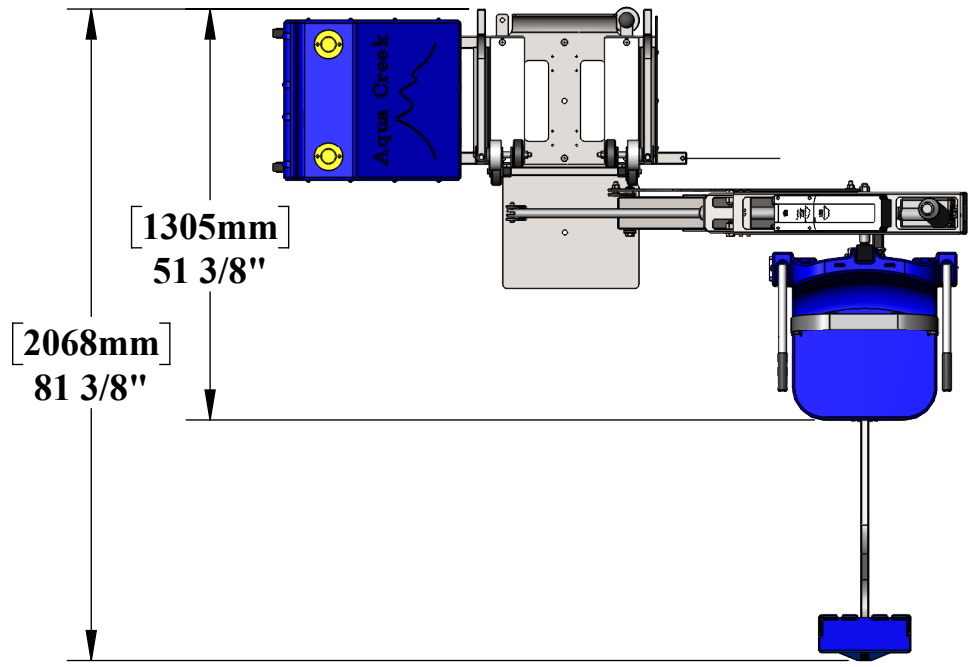

9889 GARRYMORE LANE  
 MISSOULA, MT 59808  
 (406) 549-0769  
 FAX (406) 549-2602

NOTE:  
 \*SPECIFICATIONS ARE SUBJECT TO CHANGE WITHOUT NOTICE

PRODUCT:		PATRIOT-AT1	
PART #:		F-12PPL-HD-AT1	
SCALE:	1:24	DATE:	6/14/2019
DRAWN BY:	KR	REVISION:	05