

12" SQUARE WAVE ANTI-ENTRAPMENT SUCTION OUTLET COVER, VENTED RISER RING AND MUD FRAME



**VGB CERTIFIED
SPECIFICATIONS**

Floor Flow Rating
361 GPM at 1.3 fps

Wall Flow Rating
361 GPM at 1.3 fps

Sump Depth
3" minimum

Open Area
90.8 in²

FEATURES

All components meet or exceed ANSI/APSP 16-2011 and NSF/ANSI 50-2009a national standards and ASTM G154 UV testing exposure

Easily and safely retrofits to 12" square 3/4" deep frames

#316 stainless steel screws

Manufactured from superior UV-resistant engineered polymers

Trademarked VGB compliance button easily identifies VGB 2008 compliant cover from on deck and underwater

Online product support including downloadable CAD files, General Certificate of Conformity, third-party certificate, installation instructions and more

Replace drain cover every five years from the date of installation

See next page for additional product configurations

8 per case

U.S. patents D623727 and D663388

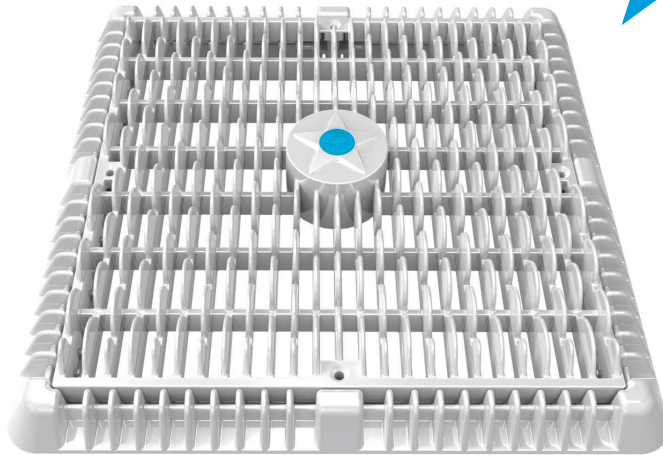

Part # WAV12WRxxx

Fits: AquaStar standard 12" models and American (Pentair) with 3/4" deep existing frames and four screw hole pattern.

STANDARD COLORS

- WAV12WR101 – White
- WAV12WR102 – Black
- WAV12WR103 – Light Gray
- WAV12WR104 – Blue
- WAV12WR105 – Dark Gray
- WAV12WR108 – Tan

Replaces p/n 12xxx, P12xxx, SRFS12xxx, SUN12xxx, SUN12WRxxx, WAV12xxx, 12MFxxx

VGB 2008 Compliant

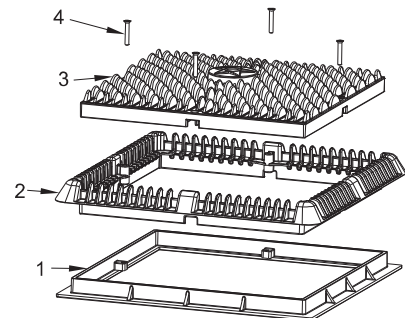
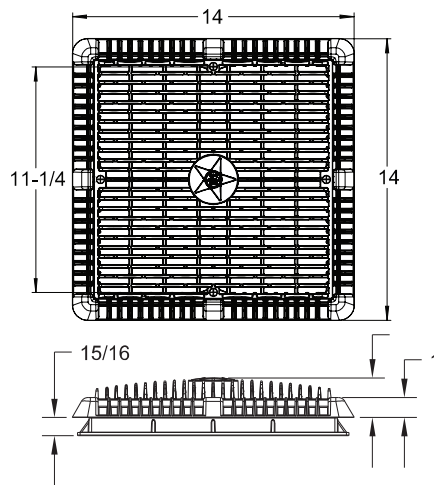

1. 12" Square Mud Frame
2. 12" Square Vented Riser Ring
3. 12" Square "Wave" Suction Outlet
4. 10 x 1-3/4" Flat Head Phillips, 316 SS, Qty 4

P 877-768-2717 F 877-276-POOL Outside the US: P +1-949-336-1940 F +1-949-336-1940
info@aquastarpoolproducts.com www.aquastarpoolproducts.com

12" SQUARE WAVE ANTI-ENTRAPMENT SUCTION OUTLET COVER WITH 3" SOCKET SUMP



VGB CERTIFIED SPECIFICATIONS

Floor Flow Rating
361 GPM at 1.3 fps

Wall Flow Rating
361 GPM at 1.3 fps

Sump Depth
Use sump included

Open Area
90.8 in²

FEATURES

All components meet or exceed ANSI/APSP 16-2011 and NSF/ANSI 50-2009a national standards and ASTM G154 UV testing exposure

Sump manufactured from strong PVC sump with 3" socket and 4" spigot side port, and 2" socket 2 1/2" spigot bottom port

Drain cover manufactured from superior UV-resistant engineered polymers

Comes with 3" and 2" NPT cap with o-ring for pressure testing and winterizing

#316 stainless steel screws

Trademarked VGB compliance button easily identifies VGB 2008 compliant cover from on deck and underwater

Online product support including downloadable CAD files, General Certificate of Conformity, third-party certificate, installation instructions and more

Replace drain cover every five years from the date of installation

1 per case

U.S. patents D623727 and D663388

NEW Hassle-free pressure testing and winterizing



Optional 2" hydrostatic relief valve available p/n SK43101

Hassle-free pressure testing and winterizing
Comes with a 3" and 2" NPT cap with O-ring. *No knock-outs required.*

Part # WAV12WRxxxSSB

STANDARD COLORS

- WAV12WR101SSB – White
- WAV12WR102SSB – Black
- WAV12WR103SSB – Light Gray
- WAV12WR104SSB – Blue
- WAV12WR105SSB – Dark Gray
- WAV12WR108SSB – Tan

VGB 2008 Compliant

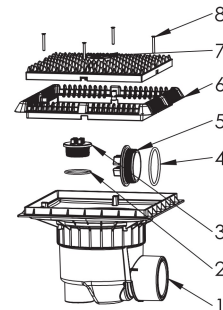
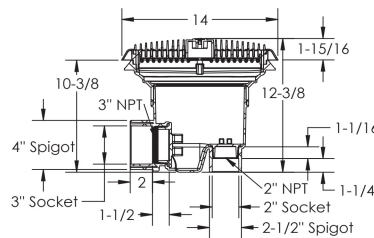
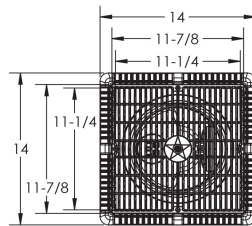

1. Side Port Sump Bucket, 12" Square Frame
2. 2" Plug O-Ring
3. 2" NPT Plug
4. 3" Plug O-Ring
5. 3" NPT Plug
6. 12" Square Riser Ring
7. 12" Square "Wave" Suction Outlet Cover
8. 10 x 13/4" Flat Head Phillips, 316 SS, Qty 4

P 877-768-2717 F 877-276-POOL Outside the US: P +1-949-336-1940 F +1-949-336-1940
info@aquastarpoolproducts.com www.aquastarpoolproducts.com

12" SQUARE WAVE ANTI-ENTRAPMENT SUCTION OUTLET COVER, VENTED RISER RING AND MUD FRAME



**VGB CERTIFIED
SPECIFICATIONS**

Floor Flow Rating
361 GPM at 1.3 fps

Wall Flow Rating
361 GPM at 1.3 fps

Sump Depth
3" minimum

Open Area
90.8 in²

FEATURES

All components meet or exceed ANSI/APSP 16-2011 and NSF/ANSI 50-2009a national standards and ASTM G154 UV testing exposure

Manufactured from superior UV-resistant engineered polymers

No transitional glue required

Comes with 6" tapered threaded pipe plug for easy pressure testing and winterization

#316 stainless steel screws

Online product support including downloadable CAD files, General Certificate of Conformity, third-party certificate, installation instructions and more

Replace drain cover every five years from the date of installation

1 per case



Part # WAV12WRxxxF

STANDARD COLORS

- WAV12WR101F – White
- WAV12WR102F – Black
- WAV12WR103F – Light Gray
- WAV12WR104F – Blue
- WAV12WR105F – Dark Gray
- WAV12WR108F – Tan

VGB 2008 Compliant

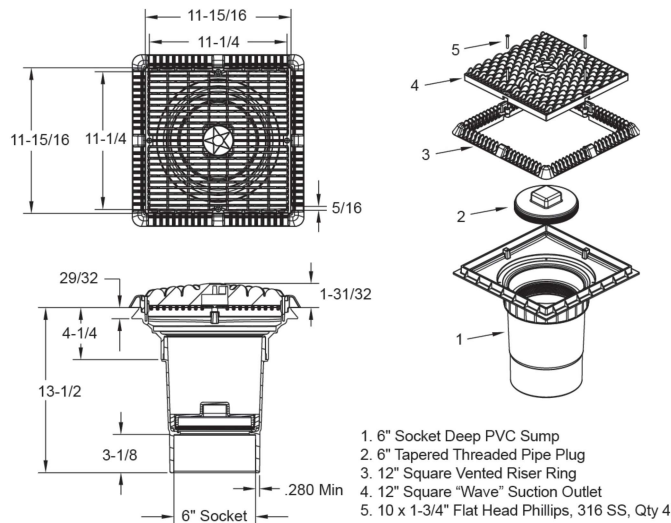

P 877-768-2717 F 877-276-POOL Outside the US: P +1-949-336-1940 F +1-949-336-1940
info@aquastarpoolproducts.com www.aquastarpoolproducts.com