

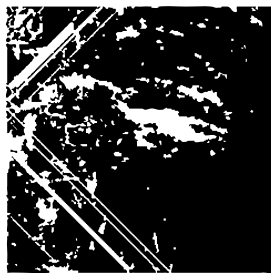

WATER BOWL FEATURE INSTALLATION INSTRUCTIONS

SAVE THESE INSTRUCTIONS FOR FUTURE REFERENCE

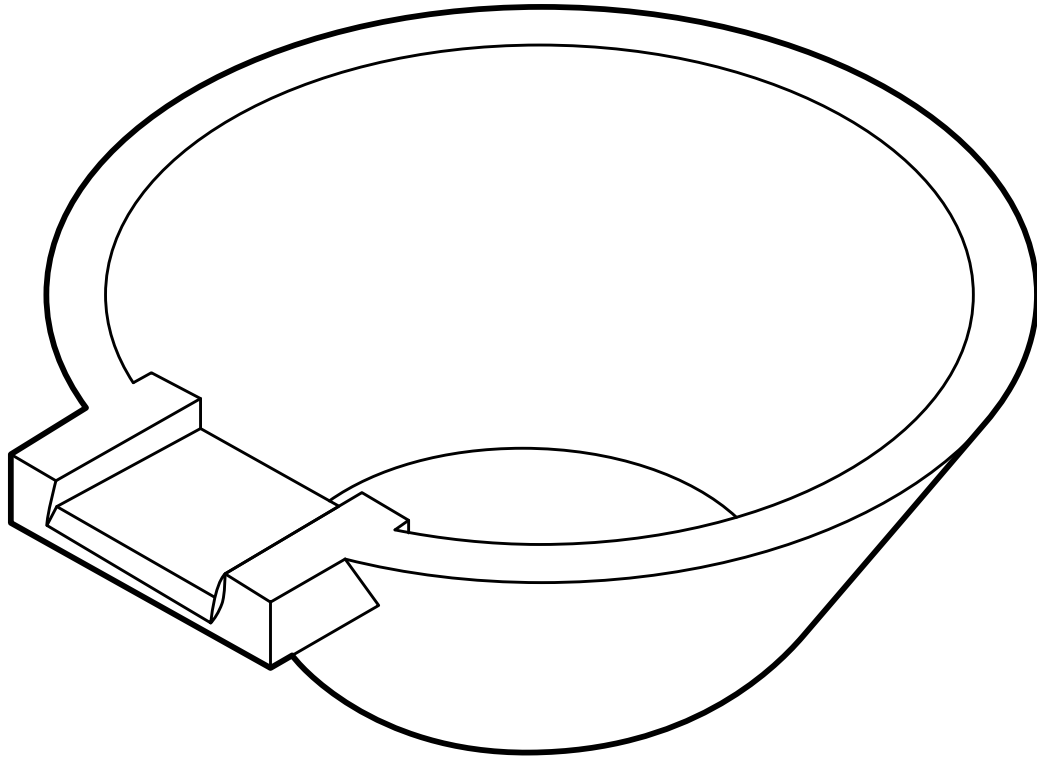

bobé

WATER & FIRE FEATURES

IMPORTANT SAFETY INFORMATION: READ AND FOLLOW ALL INSTRUCTIONS

Save these instructions. Leave manual with homeowner after installation.

Improper installation, adjustment, alteration, service, or lack of maintenance can cause injury or property damage. Read the installation, operating, & maintenance instructions thoroughly before installing or servicing this equipment.

A. SPECIFICATIONS

1. PRODUCT DETAILS

MATERIAL

- Water bowls are constructed of 14 gauge 316 stainless steel or 16 gauge copper
- All bowls are fully TIG welded
- Stainless steel and copper have different characteristics and maintenance requirements. For details see section F.

BONDING LUG

- All water bowls come with a bonding lug on the back.
- This is a grounding lug used to ground the water bowl.

INLET: All water bowls are manufactured with a 1 1/2" NPT female inlet on the bottom.

2. DIMENSIONS

- Bottom measurement is equal to 1/2 bowl width (Ex: 24" bowl has 12" base).
- Main body length and width are equal measurements.

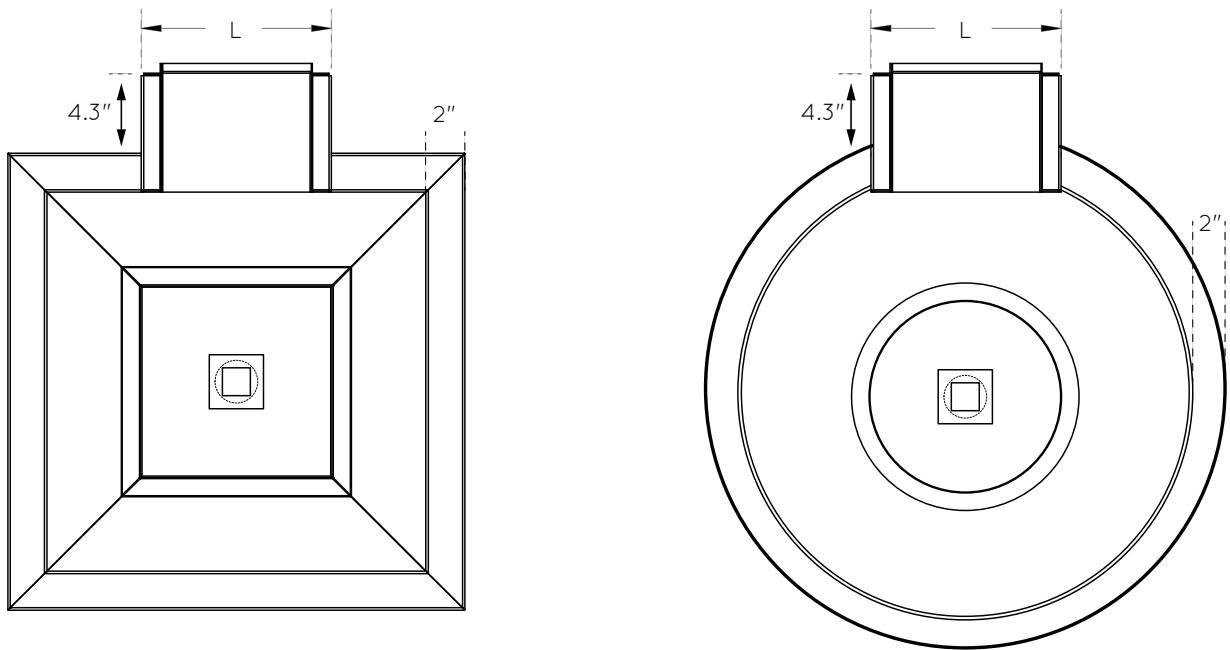

FIGURE 1

SPILLWAY LIP SIZE (L)			
24"	28"	32"	36"
10" WIDE	11" WIDE	12" WIDE	14" WIDE

B. INSTALLATION

1. MOUNTING SURFACE

- Bowls should always be installed on a solid, level surface
- The PVC pipe will hold the water bowl in place. Water and fill material will also weigh the bowl down, but a construction adhesive can also be used for extra security.

2. PLACEMENT & CENTERING

- Install a 1.5" PVC water line in column or mounting surface, in the center of the water bowl.
- EXTENDED LIP MODELS: Locate so that the lip of the water bowl fully extends into the pool or body of water.
 - Center of bowl should be maximum of half the water bowl diameter from the edge
 - EXAMPLE: For 24in water bowl, center of bowl can be a maximum of 12in (half bowl width) from the edge of the water. (Fig 2a)
- SEAMLESS LIP MODELS: Locate so that the body of the bowl extends over the edge of the pool
 - Center of bowl should be positioned to leave 2-3 inches of bowl overhang over the edge
 - EXAMPLE: For 24in water bowl, center of bowl can be a maximum of 9in (3 inch clearance) from the edge of the pool. (Fig 2b)

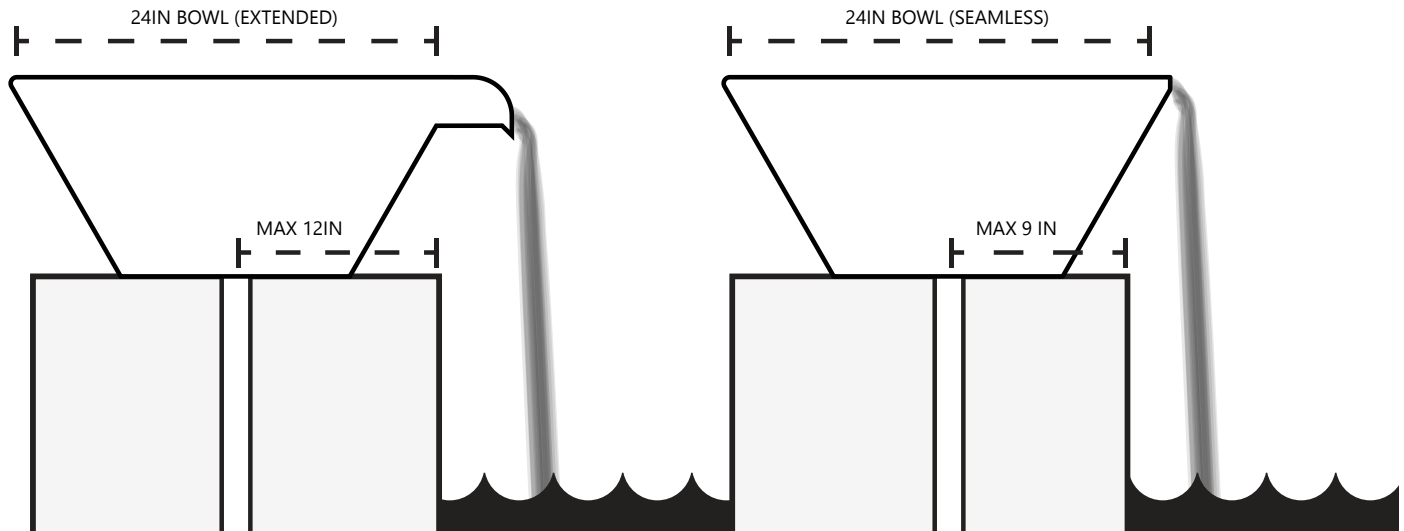

FIGURE 2a

FIGURE 2b

D. PLUMBING

1. PLUMBING INSTALLATION

a. RECOMMENDED PLUMBING

- Use multiple pumps when installing multiple water features.
- The dedicated pump should be plumbed with a minimum of 2" PVC pipe.
- VGB compliant suction covers must be used.
- A filter strainer is recommended between the pump and the water bowl.

b. PLUMBING CONNECTION

- Water bowls have a 1 ½" female threaded inlet in the bottom center.
- About two inches above the inlet inside the bowl is a "hat bracket" that slows the water coming up from the water line to minimize turbulence. This also helps prevent bowl media from falling back into the pipe.

c. BALANCING THE FLOW

- A 3-way valve is recommended after the pump to allow the flow to be regulated between the water bowl and the pool return. The recommended location for this valve is after the filter near the equipment pad. (Fig 3)
- When plumbing two or more water bowls, follow all of the previous instructions with the addition of a 2-way ball valve for each water feature. The valve is necessary to balance the water flow between the units. (Fig 4b)
- The dedicated pump should be plumbed with a minimum of 2" PVC pipe.

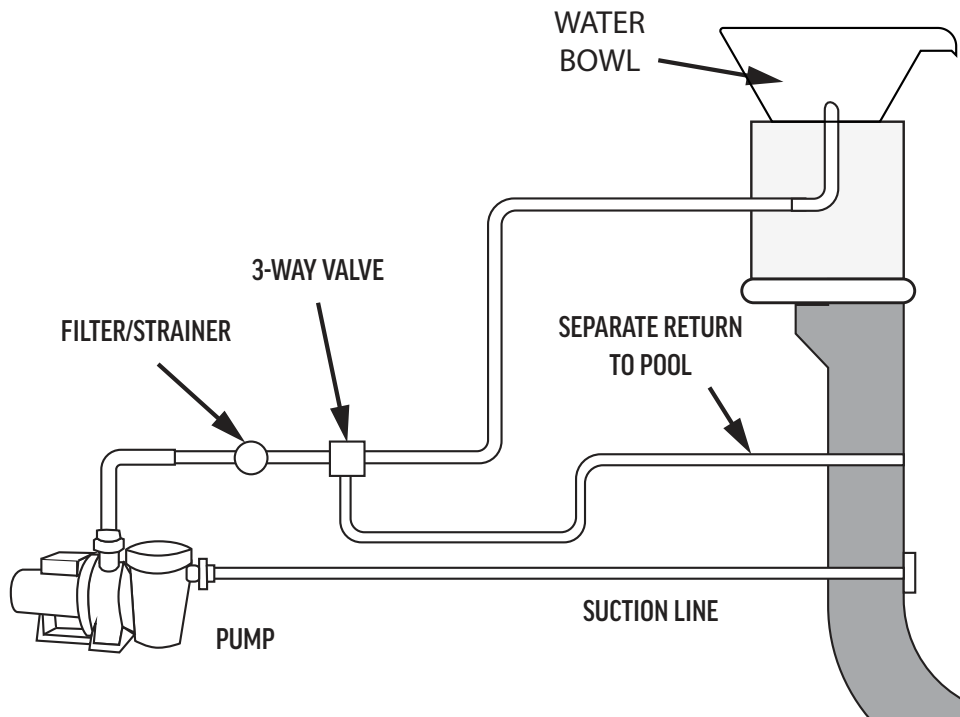
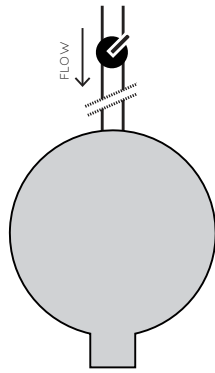

FIGURE 3

D. PLUMBING



ONE BOWL

FIGURE 4a

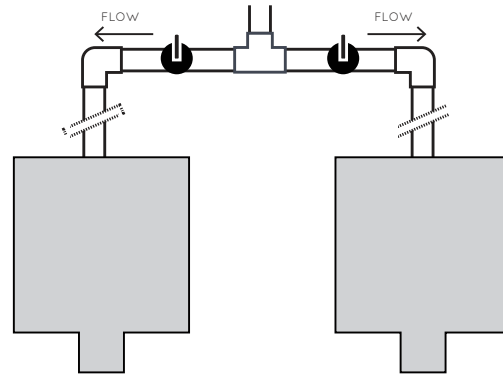

MULTIPLE BOWLS

FIGURE 4b

3. FLOW RATES

Flow rates vary by product size and design

24"W × 7"H	24"W × 12"H	28"W × 12"H	32"W × 12"H	36"W × 16"H
15-20 GPM	15-20 GPM	15-20 GPM	20-25 GPM	20-25 GPM

4. FLOW TEST

- Open water valves
- Turn on water source
- Adjust valve to correct flow rate
- Adjust valves per bowl to balance flow on multiple bowl set-ups
- Turn off water valve or water source
- Check for leaks at base of bowl and all fitting connections

E. FILL MEDIA

- Bowls can be optionally filled with rock or colored glass media
- Fill level about 1/4 inch below the lip of the bowl to minimize media overflow into the pool
- Fill media type, size and fill level will have different effects on water flow. Experiment to achieve the desired flow and effect.

F. MATERIAL CARE GUIDE

COPPER

PATINA: Dark brown to green to blue. All copper products will patina. Patina is a natural process of oxidation where copper reacts to the elements and produces a series of colors that build up in order to protect the copper. The final color can vary widely depending on location, environment and other factors.

WHAT COLOR WILL MY PRODUCT BE?

All products ship in their natural copper state. Depending on where they are stored or transported, patina may begin to develop. It is **very likely** the color may change between manufacture and delivery and will continue to patina after installation. Copper can be cleaned after installation to reset the patina process.

CLEANING

- Patina color may vary from piece to piece, even when delivered on the same day. If you prefer to restore the material after installation, a cleaning solution such as TarnX® may be used.
- Hand Prints/Water Spots: Products develop hand prints from handling or water stains from water testing. The natural patina process will cover up the markings as the whole piece begins to darken.

STAINLESS STEEL

PATINA

Stainless steel does not develop a patina.

CLEANING

- Stainless steel is steel that is “stain-less” however, this DOES NOT MEAN THAT STAINLESS STEEL WILL NEVER RUST OR CORRODE. Stainless steel can show water spots and deposits of minerals or other natural substances that appear, orange, white and/or brown. We suggest regular cleaning, at least once a month.
- Use distilled, soft or purified water (preferably warm) while cleaning and as a last rinse. Dry with a soft cloth.
- General maintenance and/or light buildup can be done with a soft cloth. Windex works well if you want to remove water spots. Otherwise a mild soap or vinegar (1 part vinegar to 3 parts water) will remove light buildup.
- Try to go in the direction of the natural polishing grains
- Heavier build-up can be cleaned using very fine red Scotch-Brite™ cleaning pads.
- In many cases, cleaning over time will greatly reduce reappearance of build-up.

SALTWATER

Stainless steel is not warranted for use in or around salt water. Bobé products are made of 316 marine grade stainless steel. Stainless steel can get water spots and stainless steel can get deposits of minerals or other natural substances that appeared, white and/or brown. If this happens you'll need to clean the areas each time the build up occurs and after 3-6 cleanings the problem areas should be free of any build up returning.

SAVE THESE INSTRUCTIONS

Record Information on this System Below & Keep for Your Records

Installer _____

Purchased From _____

Installation Date _____

Model Number _____

Pool Size in Gallons _____

Customer Service & Tech Support

Toll Free: 1-800-733-9060

support@c-m-p.com

Warranty Questions

bobecare@c-m-p.com

Support Resources & Videos Online

c-m-p.com/support

