

9 LEADS TO EXTEND 4.000 +2.000, -0.000 INCHES BEYOND TERMINAL COVER AND TUCKED UNDER TERMINAL COVER. WRAP WITH A CABLE TIE. LEADS TO BE SKINNED .750

GROUND LUG

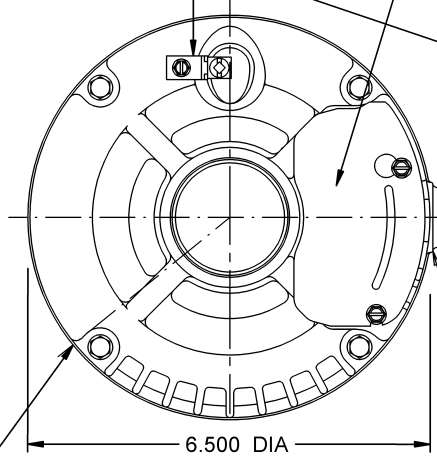

SEAM WELD

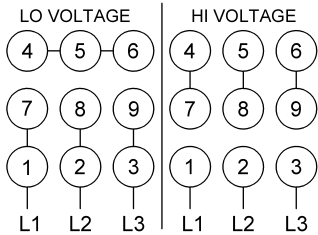

TO REVERSE ROTATION, INTERCHANGE ANY TWO LINE LEADS.
 WITH ABC PHASE SEQUENCE
 PHASE A - LINE 1
 PHASE B - LINE 2
 PHASE C - LINE 3
 ROTATION: CW LEAD END

NOTES:

- 1.) MOTOR TO BE SHIPPED CONNECTED FOR 230 VOLTS (LO VOLTS).
- 2.) SHAFT EXTENSION 303 STAINLESS STEEL.

1/2-20 UNF-2A RH THREAD

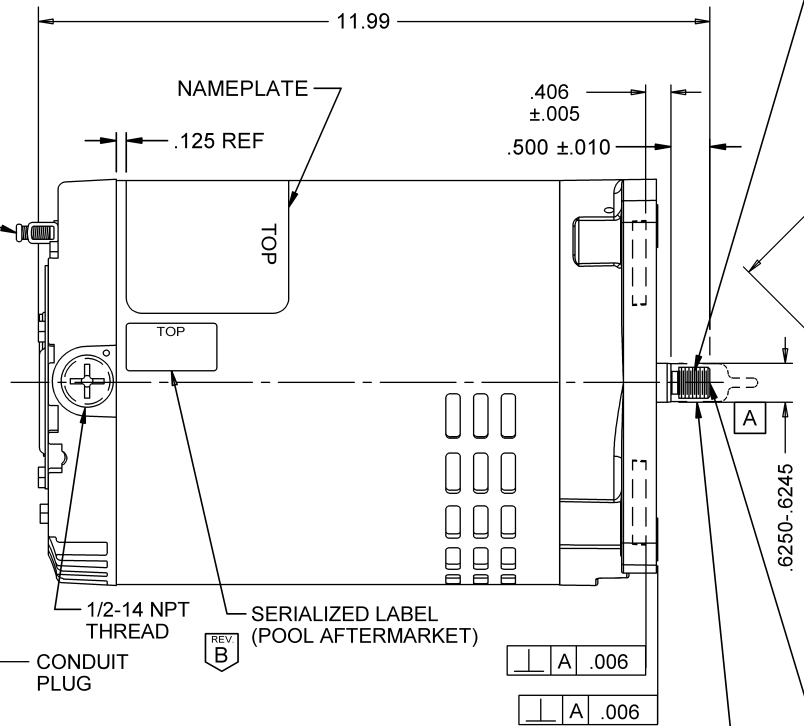

THREAD PROTECTOR

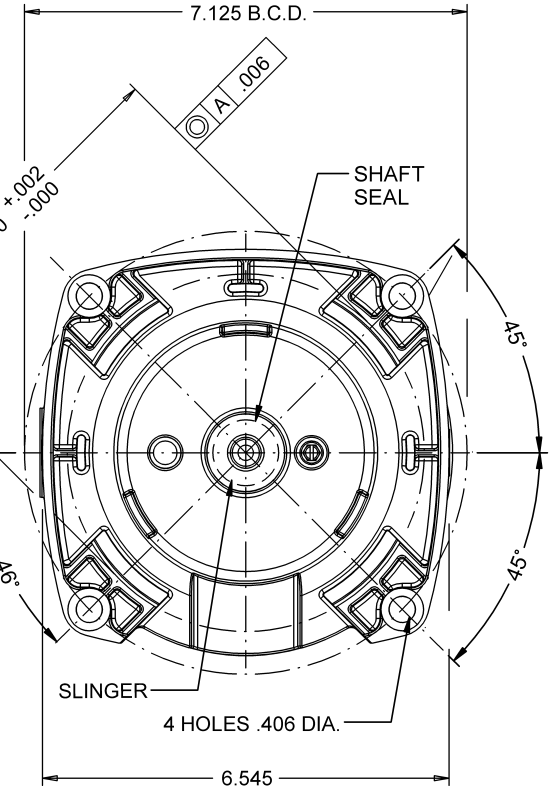

1/4-20 UNC 2B, LH INTERNAL THRD. .625 IN. DEEP MIN.

MODEL	REF	CUSTOMER	HP	VOLTS	AMPS	HZ	RPM	S.F.	S.F. AMPS	
P63GEN-4519		POOL AFTERMARKET	2.0	208-230/460		60/50	3450/2850	1.30/1.00	7.0-6.6/3.3	
REVISION RECORD FOR: C7458-08								ROTATION		CUSTOMER PN
SHEET NUMBER: 1 OF 1, REV: B, ADDED SERIALIZED LABEL.								CW LEAD END		EH637
REVISION DATE: 22-APR-13								INFORMATION DISCLOSED ON THIS DOCUMENT IS CONSIDERED PROPRIETARY AND SHALL NOT BE REPRODUCED OR DISCLOSED WITHOUT WRITTEN CONSENT OF NIDEC MOTOR CORPORATION NIDEC MOTOR CORPORATION		
ISSUED BY: B. ANDRADE, REVIEWED BY: J. SCHRADER, ENGINEER APPROVED: J. SCHRADER										
TITLE: ASSEMBLED VIEW								CODE: V01	ITEM NO.: 770398	SIZE: B

NIDEC MOTOR CORPORATION 22-Apr-13