

# Commercial Swimming Pool Pumps

Models: 4SPC10EC  
4SPC15EC  
4SPC20EC

## Instructions For: Installation, Operation, & Safety Service

---

**INSTALLER:** PLEASE LEAVE THIS MANUAL FOR THE OWNER'S USE.

---

**PLEASE FILL IN DATA FROM YOUR  
PUMP NAMEPLATE**

Pump Model: \_\_\_\_\_

Spec. No. \_\_\_\_\_

Serial No. \_\_\_\_\_

Seal No. \_\_\_\_\_



**SAFETY  
INSTRUCTIONS**

This safety alert symbol will be used in this manual and on the pump instructions decal to draw attention to safety related instructions. When used, the safety alert symbol means ATTENTION! BECOME ALERT! YOUR SAFETY IS INVOLVED! FAILURE TO FOLLOW THESE INSTRUCTIONS MAY RESULT IN A SAFETY HAZARD.

**Marlow**



**ITT Industries**  
*Engineered for life*

## **WARRANTY**

WARRANTY – Company warrants title to the product(s) and, except as noted with respect to items not of Company's manufacturer, also warrants the product(s) on date of shipment to Purchaser, to be of the kind and quality described herein, and free of defects in workmanship and material.

THIS WARRANTY IS EXPRESSLY IN LIEU OF ALL OTHER WARRANTIES, INCLUDING BUT NOT LIMITED TO IMPLIED WARRANTIES OF MERCHANTABILITY AND FITNESS, AND CONSTITUTES THE ONLY WARRANTY OF COMPANY WITH RESPECT TO THE PRODUCT(S).

If within one year from date of initial operation, but not more than eighteen months from date of shipment by Company of any item of product(s), Purchaser discovers that such item was not as warranted above and promptly notifies Company in writing thereof, Company shall remedy such nonconformance by, at Company's option, adjustment or repair or replacement of the item and any affected part of the product(s). Purchaser shall assume all responsibility and expense for removal, reinstallation, and freight in connection with the foregoing remedies. The same obligations and conditions shall extend to replacements parts furnished by Company hereunder. Company shall have the right of disposal of parts replaced by it.

ANY SEPARATELY LISTED ITEM OF THE PRODUCT(S) WHICH IS NOT MANUFACTURED BY THE COMPANY IS NOT WARRANTED BY COMPANY and shall be covered only by the express warranty, if any, of the manufacturer thereof.

THIS STATES PURCHASER'S EXCLUSIVE REMEDY AGAINST COMPANY AND ITS SUPPLIERS RELATING TO THE PRODUCT(S), WHETHER IN CONTRACT OR IN TORT OR UNDER ANY OTHER LEGAL THEORY, AND WHETHER ARISING OUT OF WARRANTIES, REPRESENTATIONS, INSTRUCTIONS, INSTALLATIONS OR DEFECTS FROM ANY CAUSE. Company and its suppliers shall have no obligation as to any product which has been improperly stored or handled, or which has not been operated or maintained according to instructions in Company or supplier furnished manuals.

# CONGRATULATIONS

You are now the owner of a Marlow pump. This pump was carefully inspected and subjected to final performance tests before releasing for shipment. In order to achieve maximum performance, please follow the simple instructions in this manual.

## RECOMMENDED PRECAUTIONS

1. Avoid system pressures that may exceed one and a half times the operating point selected from the pump performance curve.
2. Should the fluid temperature rise more than 50°F above ambient, expansion joints must be installed on both the suction and discharge ports to relieve stress on the pump casing.
3. All electrical wiring of the pump installation must be done by a licensed electrician who will observe all national and local electrical codes. All motors require a magnetic starter with current over-load protection.
4. No modifications, additions or deletions should be made to the pump, without prior approval of the factory.
5. In systems where shock wave pressures may be generated, protective devices such as check valves/gate valves, etc., must be installed on discharge line to prevent shock pressures from entering the pump casing.
6. In systems containing discharge check valves, gate valves, etc., pump will not prime against a closed valve. Check the discharge valves making sure they are open before attempting to prime pump. If there is a possibility of air being entrapped in the pump casing, install an automatic venting device to bleed off the air.
7. This pump is designed primarily for water use. Before pumping other liquids, read carefully the CAUTION to the right.
8. Overheated pumps are dangerous. Burns or explosion could occur due to steam pressure. Operating pumps with suction and discharge closed is one cause of severe overheating. If overheating of pump casing occurs:
  1. Stop pump immediately.
  2. Allow pump to cool.
  3. Slowly and cautiously vent pump.
9. Drain casing completely when servicing pump.
10. Do not use in a combustible atmosphere.
11. Make frequent checks of the tightness of suction and discharge pipe, drain, filter plug and pump gaskets.
12. After servicing the pump, always install any safety devices as originally found prior to disassembly.



### CAUTION: READ CAREFULLY

The performance of Marlow pumps is based upon clear, cold, fresh water with suction conditions as shown on the performance curve. If used to pump other liquids, pump performance may differ from rated performance based on the different specific gravity, temperature, viscosity, etc. of the liquid being pumped. A standard pump may not be safe for pumping all types of liquids, such as toxic, volatile or chemical liquids, or liquids under extreme temperatures or pressures. Please consult Marlow catalogs as well as local codes and general references to determine the appropriate pumps for your particular application. Since it is impossible for us to anticipate every application of a Marlow pump, if you plan to use the pump for a non-water application, *consult Marlow beforehand to determine whether such application may be proper or safe under the circumstances. Failure to do so could result in property damage or personal injury.*

## OPERATING INSTRUCTIONS

### GENERAL

This pump was designed for the purpose of being used as a circulation pump for swimming pools. For other applications, consult the manufacturer.

Our shipping container has been specifically designed to prevent transit damage. Any damage should be carefully noted on the delivery ticket and a claim filed promptly with the carrier.

### LOCATION

Locate the pump as close as possible to the pool (never more than 8 feet above pool water level). Install on a rigid foundation, preferably 2" or more above ground level. Provide the necessary space around the pump for future inspection and servicing of the unit. We recommend a louvered housing to protect exposed motors from the sun and rain. Allow for ventilation. Housing should clear the motors by a minimum of 10" at all points.

### INSTALLATION

1. Suction line should be as large as the suction port of the pump. All piping must be air tight. If possible keep all suction lines below pool water level until just before the pump. Suction lines should slope toward the pump.

2. It is recommended that pipe unions be installed on the suction and discharge pipes close to the pump. Thus, the pump-motor assembly may be removed with ease for service and storage.
3. Tighten the pump fittings only as much as it is required to insure a tight connection (two turns past hand tight is sufficient). Excessive torque (more than 30-foot pounds) is unnecessary and may damage the pump.
4. The weight of the piping should be supported independently and not carried by the pump.

### ROTATION

The pump is specifically designed to rotate in a counter clockwise direction when viewing the motor from the pump suction. Three-phase motors can rotate in either direction. Momentarily, start or "bump" the motor to check the rotation of the pump shaft. Interchanging any two leads of a three-phase motor will reverse the rotation.

### PRIMING

Fill the pump tank with water before starting. This may be done through the strainer cover or filler plug provided on pump casing. This is necessary to allow pump to prime and to *prevent permanent damage*. Except in freezing weather always keep liquid in the pump tank. No further lubrication of the pump end is necessary including the seal assembly. If

### PRIMING cont.

flow does not start within five minutes, stop motor and determine cause (see Trouble Guide on back page). Be sure all suction and discharge valves are open when the pump is running. Operating the pump with a closed valve in the system can cause pump damage.

### MAINTENANCE

The strainer built into the pump should be inspected and cleaned daily. These strainers are easy to clean. Loosen the hand knob(s) and remove the strainer cover to expose the strainer basket. Remove the basket and clean. Inspect the cover gasket; if damaged, replace. Install the strainer cover, tightening hand knob by hand only. The pump seal requires no lubrication. The electric motor has bearings and you should refer to the motor manufacturer's instructions for proper maintenance.

### STORAGE

If your pool is deactivated until next season, care must be taken to protect the pump-motor from damage and exposure. Over the winter, store the pump-motor unit in a warm, dry location.

**NOTE:** Be certain power is turned off at the control panel. Next drain the casing by removal of both drain plugs. Disconnect the suction and discharge lines at the union connections, then move unit to warm, dry indoor location.

### REPLACEMENT PARTS

This unit is designed to provide maximum electrical safety. To assure continued protection against shock hazard use only identical factory supplied replacement parts when servicing.



### CAUTION

The performance of Marlow pumps is based upon clear, cold, fresh water with suction conditions as shown on the performance curve. If used to pump other liquids, pump performance may differ from rated performance based on the different specific gravity, temperature, viscosity, etc. of the liquid being pumped. However, a standard pump may not be safe for pumping all types of liquids, such as toxic, volatile or chemical liquids, or liquids under extreme temperatures or pressures. Please consult Marlow catalogs as well as local codes and general references to determine the appropriate pumps for your particular application. Since it is impossible for us to anticipate every application of a Marlow pump, if you plan to use the pump for a non-swimming pool application, *consult Marlow beforehand* to determine whether such application may be proper or safe under the circumstances. Failure to follow these instructions may result in personal injury, death or property damage.

## SAFETY INSTRUCTIONS

When installing and using this electrical equipment, basic safety precautions should always be followed, including the following:

### SAFE THESE INSTRUCTIONS:



### NOTE

This is a **SAFETY ALERT SYMBOL**. When you see this symbol on the pump or in the manual, look for one of the following signal words and be alert to the potential for personal injury or property damage.



### WARNING

1. **READ AND FOLLOW ALL INSTRUCTIONS.**
2. To reduce the risk of injury, **DO NOT PERMIT CHILDREN TO OPERATE THIS PRODUCT UNLESS THEY ARE CLOSELY SUPERVISED BY AN ADULT** at all times.



### CAUTION

3. This pump is intended for use on Swimming Pools, only as described in this manual. Do not use attachments not recommended by the manufacturer.
  4. All electrical wiring of the motor installation must be done by a licensed electrician in accordance with applicable electrical codes. Before working on motors be certain that the electrical power is off at the main junction box. Disconnect the fuse or circuit breaker and have the main switch tagged "**Do Not Energize This Switch, Personnel Working on Equipment**".
  5. Motors driving the pumps may operate at high temperatures. To avoid burns, keep hands off the motor shell, etc.
  6. Do not operate this unit without terminal cover in place.
  7. The unit must be connected only to a supply circuit that is protected by a ground-fault circuit-interrupter (GFCI). Such a GFCI should be provided by the installer and should be tested on a routine basis. Consult GFCI manufacturer's instructions for correct testing and operation.
  8. Never drop or insert any object into any opening of the pump or motor.
  9. No modifications, additions or deletions should be made to the pump.
- Failure to follow these instructions may result in personal injury, death, or property damage.

## INSTRUCTIONS FOR LICENSED ELECTRICIANS



### WARNING

All electric work must be done by a licensed electrician. Before working on motors be certain that the electrical power is off at the main junction box. Disconnect the fuse or the circuit breaker and tag the main switch: **“Do not energize this switch. Personnel working on equipment.”** Failure to follow these instructions may result in personal injury, death or property damage.

Determine the voltage of the power supply line to motor.

Voltage, phase, ampere draw, and cycles are given on the motor nameplate. Be sure the motor is properly wired to match the voltage and phase of the power supply line. On three-phase motors be certain the the motor is rotating in the proper direction. The wire used to supply power to the motor must be large enough to carry the necessary amperes for the required length without excessive voltage drop.

Be certain that the motor frame is grounded. All motors require a magnetic starter with current overload protection.

**NOTE:** Bolt length to connect 125# socket type plastic (PVC) flange to pump suction and discharge flange:

(a) **6" – 124# suction flange:**

Use 3/4" – 10x2 1/2" long bolt with 3/4" standard flat washer.

(b) **4" – 125# discharge flange:**

Use 5/8" – 11x2 1/4" long bolt with 5/8" standard flat washer.

## PUMP PARTS LIST

See Pages 6 and 7 For Exploded View Illustrations

Key	Description
1	Casing
2	Pipe Plug
3	Pipe Plug
* 4	Locknut, Impeller
* 5	Washer, Curved
■ 6	Impeller, Closed
* 7	Gasket, Diecut/Molded
* 8	Gasket, Diecut
* 17	Seal, Single Mechanical
* 24	Sleeve, Shaft
26	Pipe Plug
* 37	Key, Impeller
■ 46	Diffuser
57	Capscrew
63	Slinger
65	Capscrew
66	Lockwasher
67	Adapter/Bracket/Lantern
* 68	Stud
69	Motor (Specify)
70	Capscrew
73	Base, Motor
* 81	Handknob
82	Stud
87	Capscrew
* 88	Gasket, Diecut
* 99	Gasket, Molded
139	Body, Strainer
■140	Cover, Strainer
* 141	Basket, Strainer

\* Recommended Spare Parts.

■ Distributor Stock, Export Spares and Critical Service.

## EXPLODED VIEW DRAWING

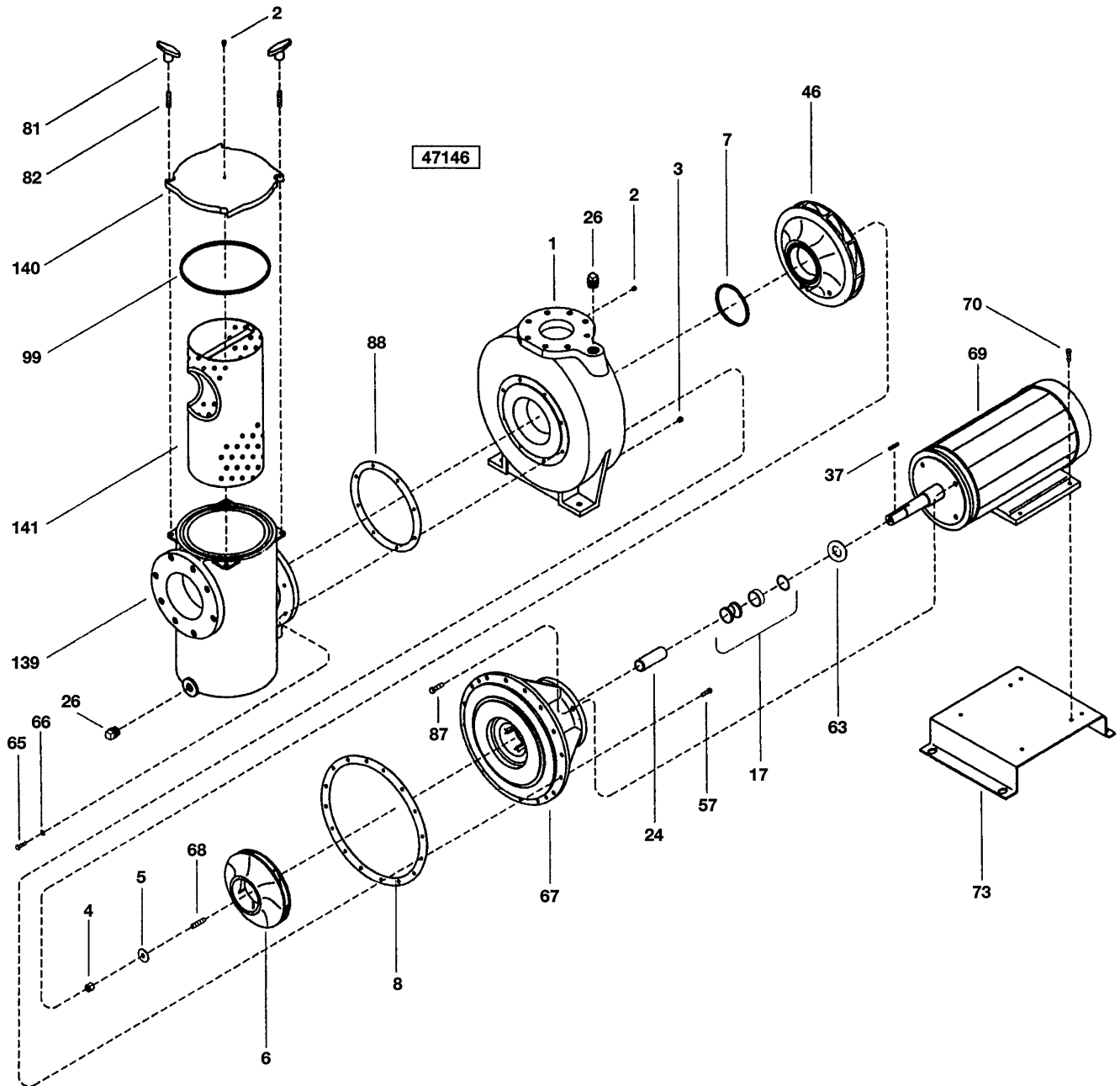

### IMPORTANT: How to USE this DRAWING to ORDER PARTS

The grouping of parts illustrations cover *different Marlow models*, including your own pump. The table on page 5 indicates the name of each part. Should you need a replacement, refer to above drawings – locate the part that matches your pump parts. Contact your local Marlow dealer and supply him with the Key Number and Description of the parts required, along with your pump Model number, Spec. number and Serial number, which are located on the pump nameplates.

# CROSS-SECTIONAL DRAWING

Numbers correspond to Parts List on page 5.

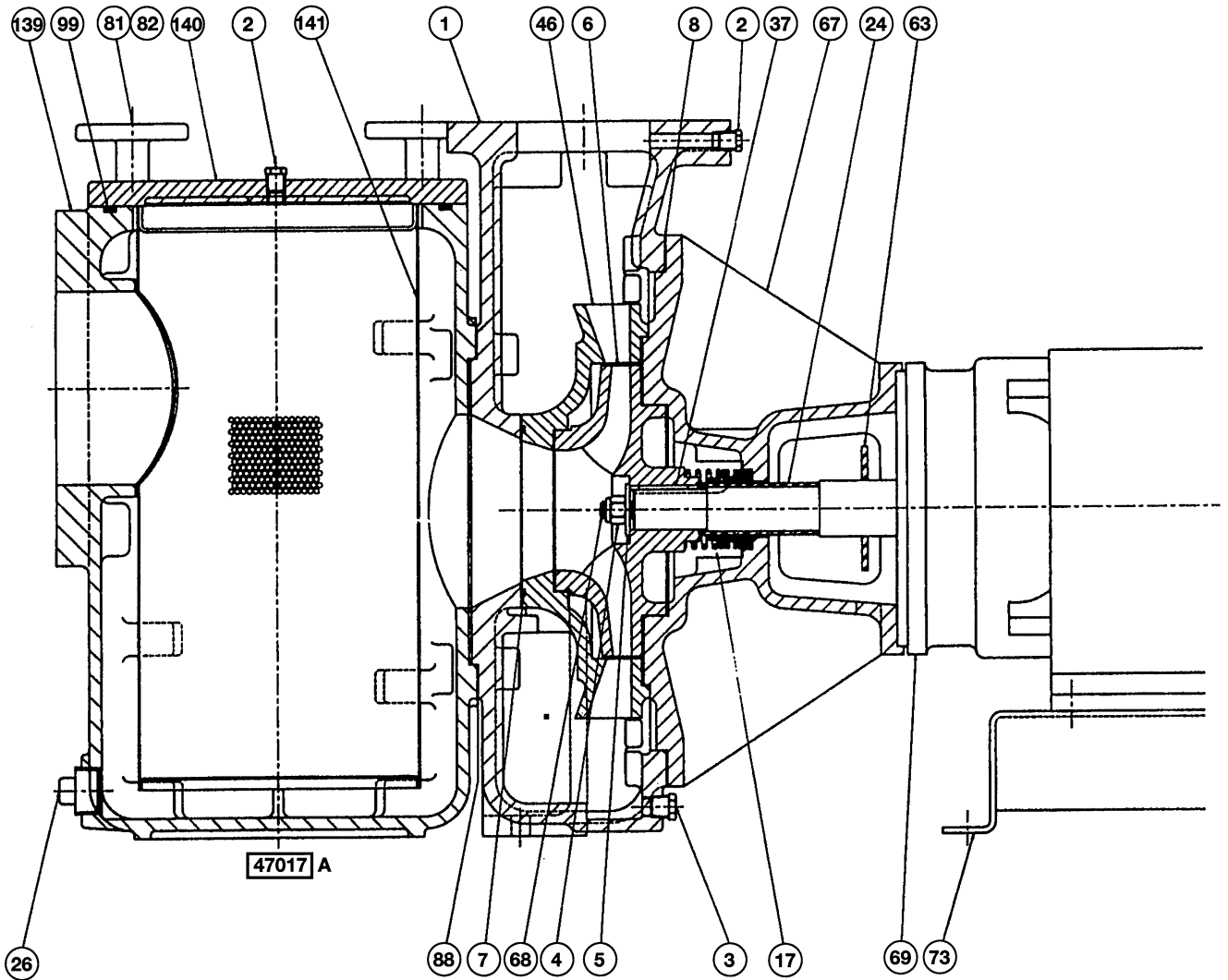

## TROUBLESHOOTING GUIDE

**NOTE:** Never work on pump without making certain power is off.

SYMPTOMS	PROBABLE CAUSE	RECOMMENDED ACTION
1. Pump will not prime	1. Suction air leak.	Make sure strainer gasket is clean and properly positioned. Tighten strainer cover down snugly. Tighten all pipes and fittings on suction of pump. Remove and replace pump seal. Be sure water in pool is high enough to flow through skimmer.
	2. No water in pump.	Make sure pump tank is full of water.
	3. Closed valves or blocked lines.	Open all valves in system. Clean skimmer and pump strainer. Open pump and check for clogging.
2. Motor does not turn.	1. No power to motor.	Check that all power switches are on. Be sure fuse or circuit breaker is properly set. Time properly set? Check motor wiring at terminals.
	2. Pump jammed.	With power off turn shaft – it should spin freely. If not disassemble and repair.
3. Low flow.	1. Dirty filter.	Back wash filter when filter pressure is "high."
	2. Dirty skimmer basket.	Clean skimmer and pump strainer basket.
	3. Suction air leak.	(See Problem 1)
	4. Closed valves or blocked lines.	(See Problem 1)
	5. Reverse rotation.	Can happen only with 3 phase motors, change any two power leads.
4. Motor runs hot.	These motors will run "hot" to the touch. However, this is normal, they are designed that way. Excessive heat can be caused by:	
	1. Low voltage or incorrect voltage.	Wiring to be corrected by licensed electrician.
	2. Installed in direct sun.	Shield motor from sun's rays.
	3. Poor ventilation.	Do not tightly cover or enclose motor.
5. Noisy operation of motor.	1. Bad Bearings.	Have electrician replace bearings in motor.
6. Noisy operation of pump.	1. Air leak in suction line. Bubbles in water returning to pool at inlet.	Repair leak. Check suction pipe, strainer cover in place? Cover gasket clean?
	2. Restricted suction line due to blockage or under-size pipe. Indicated by high vacuum reading at pump suction.	Remove blockage or increase suction pipe size. Make sure strainer basket is clean. Are all suction valves <i>fully</i> open?
	3. Foreign matter (gravel, metal, etc.) in pump impeller?	Disassemble pump and remove foreign matter from impeller.
	4. Cavitation.	Improve suction conditions. (Reduce suction lift, reduce number of fittings, increase pipe size.) Increase discharge pressure and reduce flow by throttling discharge valve.
7. Motor overload protection "Kicks Out".	1. Motor is improperly connected.	Check wiring diagram on motor.
	2. Low voltage due to undersized wire or low incoming voltage.	Check with volt meter. Increase size of supply wire. Report low supply voltage to power company. Voltage at motor <i>must</i> be within 10% of motor nameplate voltage.
	3. Wrong size heaters in protective device.	Heaters should be one size larger than full load amps shown on motor nameplate.
	4. Overload due to binding in pump or wrong size impeller.	Indicated by high amperage readings on motor, binding shaft. Disassemble unit and correct.



**WARNING**  
Electrical Work Must Be Done  
By A Licensed Electrician.



ITT Industries



**ISO 9001  
Certified**

# Marlow

Marlow  
8200 N. Austin Avenue  
Morton Grove, IL 60053  
Phone: (847) 583-2000  
Facsimile: (847) 965-8379  
<http://www.marlowpumpsonline.net>