

Deluxe 1-Meter Right-Mount Diving Tower

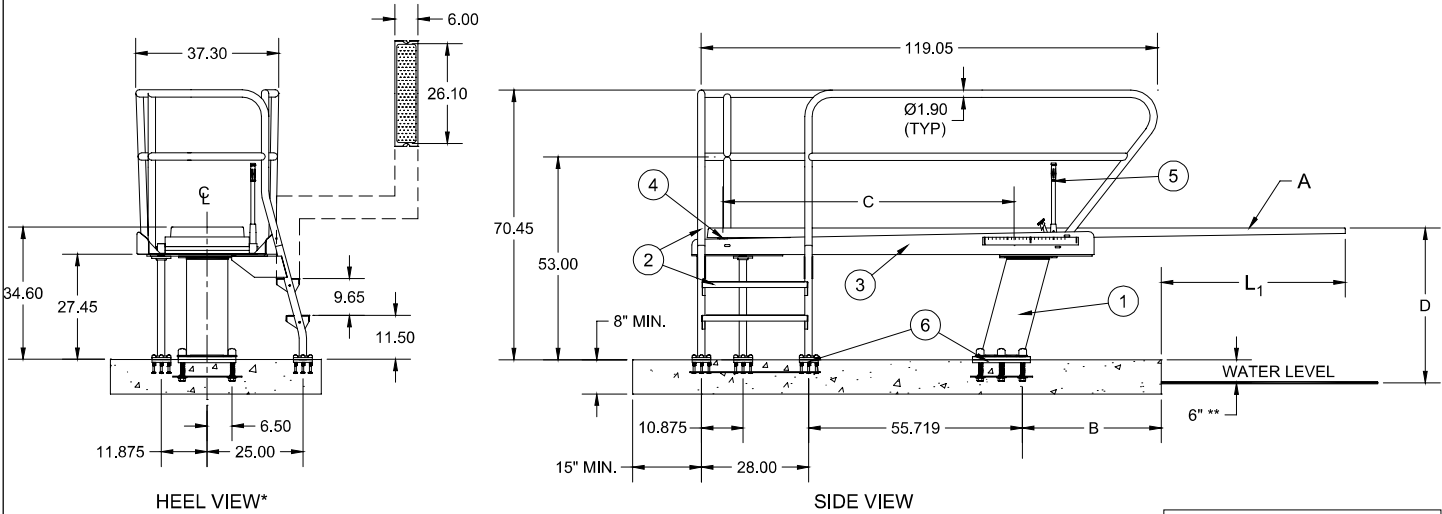

NOTE:
Diving boards (including spring boards, jump boards, and starting platforms) shall be installed only on pools meeting or exceeding the minimum requirements for the various pool types as outlined in the current edition of ANSI/NSPI-1 (for public Pools). In addition, all installations must meet or exceed applicable local codes with installation accomplished in accordance with S.R. SMITH written instructions.

ANSI/NSPI-1 1991 Standard for Public Swimming Pools

Diving Board A	Pool Type	Distance for Setting Front Bolt of Jig from Water's Edge B	Fulcrum Setting C (± 6")	Min. Overhang Overhead L ₁ (± 3")	Max. Height of Board Above Water HOW D
14"	VIII	36.25"	74"	4' 0"	39.375"
16"	VIII	60.25"	86"	4' 0"	39.375"
14"	IX	12.25"	74"	6' 0"	118.125"
16"	IX	36.25"	86"	6' 0"	118.125"

RECOMMENDED Compressive strength of concrete is 3500 psi or greater.
MINIMUM width of concrete footing: 80"
* ANSI/NSPI refers to Heel as Butt and Toe as Tip ends of board.
** WATER LEVEL MAY VARY. Adjust accordingly.
S.R. SMITH CANNOT GUARANTEE CUSTOMER'S CONCRETE OR THICKNESS.

Specification Number:	SRS-401	
Product Description:	Deluxe 1-Meter Right-Mount Diving Tower	
S.R. Smith Part Number:	CAT-1M-203R	Scale: NTS
Revision:	A	Date: 04/25/03
Written By:	T. Weil	Date: 04/25/03
Approved By:	B. Bisceglia	Date: 05/05/03
Page 1 of 2	Proprietary and confidential: The information contained in this specification is the sole property of S.R. Smith LLC. Any reproduction in part or whole without the written consent of S.R. Smith LLC is prohibited.	

S.R. Smith, LLC
P.O. Box 400, 1017 SW Berg Parkway
Canby, Oregon 97013
Tel: (888) 677-7776 (503) 266-2231
Fax: (503) 266-4334
www.srsmith.com



S.R. Smith LLC Commercial Division
Product Specifications - Written

Product Name: Deluxe 1-Meter Right-Mount Diving Tower

Part Number: CAT-1M-203R

General Notes:

The **Deluxe 1-Meter Right-Mount Diving Tower** is designed for heavy-duty use on commercial pools. All steel components are constructed from carbon steel and are primed ready for paint topcoat. This tower is to be used with either 14' (4.27m) or 16' (4.88m) diving boards.

Application:

Depending upon installation design and local codes, these models are suitable for use on commercial pools. Site and installation requirements will determine the actual stand sizes and board lengths.

Specifications:

- 1 **Front Post Assembly:** The front post assembly is fabricated and concentrically welded to form the required 15° angle of the front post when affixed to the jig assembly. The post is manufactured from 10" (254mm) dia., .250" (6.35mm) wall, schedule 20 carbon steel pipe. The lower front post plate is constructed of 15" x 15 x 3/4 (381mm x 381 x 19.05) carbon steel plate and the top post flange is constructed of 15" x 15 x 5/8 (381mm x 381 x 15.88) carbon steel plate.
- 2 **Ladder, Heel post, and Handrail Assembly:** The two (2) ladder posts and heel post are constructed of 1.90" O.D. x .145 wall (48.25mm x 3.68) type 304 stainless steel welded with a mirror finish. The steps are formed and drawn 1/16" (1.6mm) 304 stainless steel and include replaceable skid-resistant pads. The upper handrail assembly is constructed of 1.90" O.D. x .065 wall (48.25mm x 1.65) 304 stainless steel with a polished finish. The assembly is attached to the front and rear of the tray assembly.
- 3 **Tray Assembly:** The tray is formed from carbon steel and is fabricated from 3/16" (4.76mm) carbon steel plate. The tray is reinforced using 3/8" (9.53mm) carbon steel plates and is welded to the underside at both the front and rear. In addition, two (2) 1/4" (6.35mm) carbon steel gussets are welded to the upper side of the tray.
- 4 **Tie-Down Assembly:** The tie-down assembly is designed to allow easy access to components located below the board and to raise the board during swim competitions. The assembly includes a tie-down angle subassembly, two tie-down straps, and additional hardware.
- 5 **Quick Adjustable Fulcrum™:** The fulcrum assembly consists of brass gears and track that enables incremental ratcheting of the fulcrum adjustment from a standing position.
- 6 **Anchor Assembly** (p/n 12-108, 13-105, 13-106; see spec sheet for SRS-906): The anchor is constructed of carbon steel. No. 3 rebar is spot welded to six (6) 1" x 8 zinc plated carbon steel bolts to form the 3/4" thick (19.1mm) front post anchor assembly. Rebar is spot welded to 1/2" x 6 zinc plated bolts to form the 3/4" x 5 dia. (19.1mm x 127) ladder anchor assembly plates. The heel post anchor assembly is also constructed of a 3/4" x 5 dia. (19.1mm x 127) plate with four (4) 1/2" x 6 zinc plated bolts.

Additional Product Numbers: N/A.

Shipping weight: 867lbs (393kg)

Specification Number:	SRS-401	
Product Description:	Deluxe 1-Meter Right-Mount Diving Tower	
S.R. Smith Part Number:	CAT-1M-203R	
Revision:	B	Date: 04/29/14
Written By:	T. Weil	Date: 04/25/03
Approved By:	B. Bisceglia	Date: 05/05/03
Page 2 of 2	Proprietary and confidential. The information contained in this specification is the sole property of S.R. Smith LLC. Any reproduction in part or whole without the written consent of S.R. Smith LLC is prohibited.	

S.R. Smith, LLC
P.O. Box 400, 1017 SW Berg Parkway
Canby, Oregon 97013
Tel: (888) 677-7776 (503) 266-2231
Fax: (503) 266-4334
www.srsmith.com