

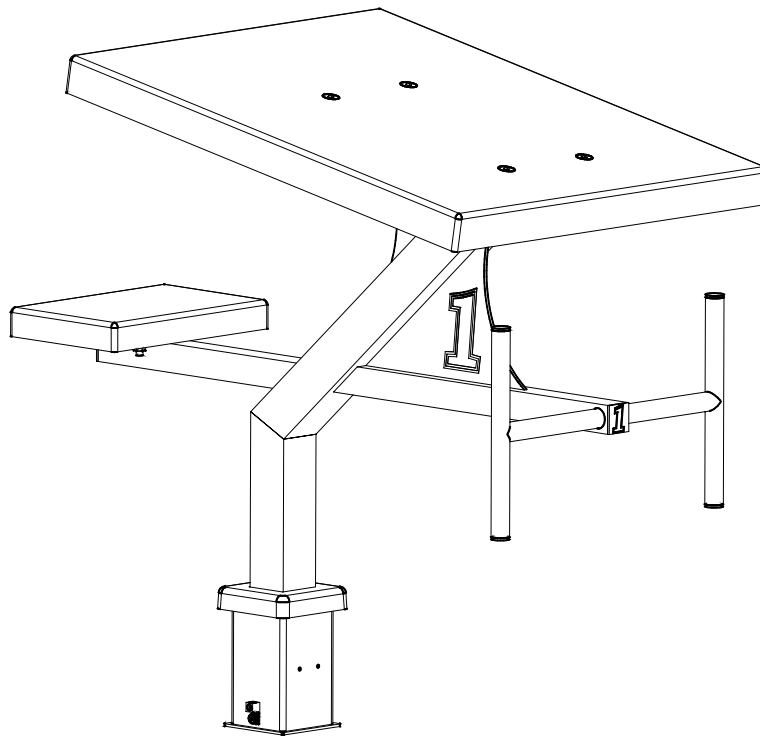

## LEGACY & LEGACY LONG REACH STARTING PLATFORMS

### INSTALLATION INSTRUCTIONS



CORPORATE HEADQUARTERS  
WESTERN SALES AND MANUFACTURING PLANT  
P.O. Box 400 • 1017 SW Berg Parkway  
Canby, Oregon 97013  
(503) 266-2231 • Fax (503) 266-4334  
[www.srsmith.com](http://www.srsmith.com)

# INTRODUCTION

The Legacy Starting Platforms are designed for use on competitive or municipal pools. Proper installation, use, and maintenance are essential for proper operation and to reduce the risk of accident or injury.

## **\*\*IMPORTANT\*\***

Check entire box and inside all packing materials for parts. Before beginning assembly, read the instructions and identify parts using the figures and parts listed in this document. It is critical that all parts be carefully inspected by the installer prior to installation to ensure that no damage occurred in transit and that a damaged part is not used. Proper installation cannot be overstressed, as an improper installation voids S.R. Smith's warranty and may affect the safety of the user.

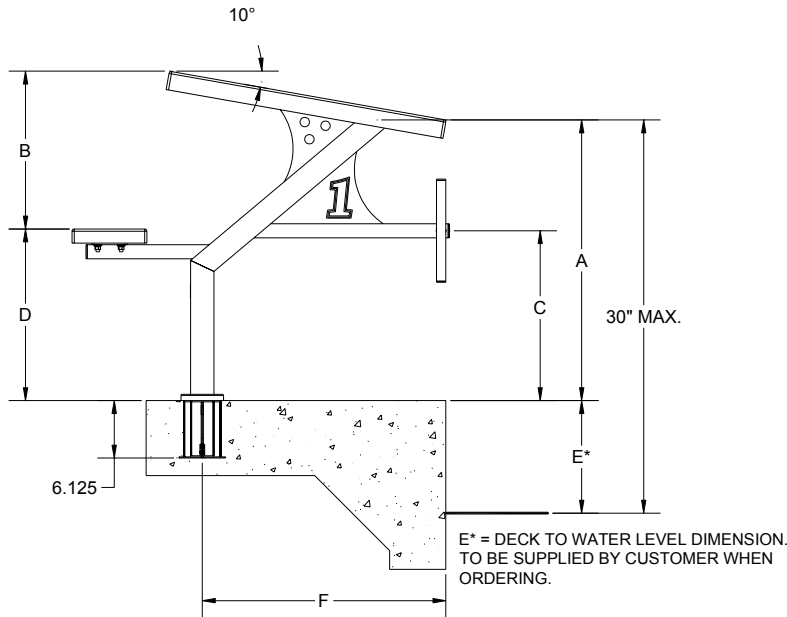

**FIGURE 1**

MODEL NUMBER	A	B	C	D	F
Legacy 26-30	30	16.75	18.00	18.25	26.00
Legacy 26-29.5	29.5	16.75	17.50	17.75	26.00
Legacy 26-29	29	16.75	17.00	17.25	26.00
Legacy 26-28.5	28.5	16.75	16.50	16.75	26.00
Legacy 26-28	28	16.75	16.00	16.25	26.00
Legacy 26-27.5	27.5	16.75	15.50	15.75	26.00
Legacy 26-27	27	16.75	15.00	15.25	26.00
Legacy 26-26.5	26.5	16.75	14.50	14.75	26.00
Legacy 26-26	26	16.75	14.00	14.25	26.00
Legacy 26-25.5	25.5	16.75	13.50	13.75	26.00
Legacy 26-25	25	16.75	13.00	13.25	26.00
Legacy 25-24.5	24.5	14.75	12.50	14.75	25.00
Legacy 25-24	24	14.75	12.00	14.25	25.00
Legacy 24-23.5	23.5	14.25	11.50	14.25	24.00
Legacy 24-23	23	14.25	11.00	13.75	24.00
Legacy 23-22.5	22.5	13.00	10.50	14.50	23.00
Legacy 23-22	22	13.00	10.00	14.00	23.00
Legacy 23-21.5	21.5	13.00	9.50	13.50	23.00
Legacy 23-21	21	13.00	9.00	13.00	23.00
Legacy 23-20.5	20.5	13.00	8.50	12.50	23.00
Legacy 23-20	20	13.00	8.00	12.00	23.00
Legacy 22-19.5	19.5	12.00	7.50	12.50	22.00
Legacy 22-19	19	12.00	7.00	12.00	22.00
Legacy 22-18.5	18.5	12.00	6.50	11.50	22.00
Legacy 21-18	18	10.75	6.00	12.25	21.00
Legacy 21-17.5	17.5	10.75	5.50	11.75	21.00
Legacy 21-17	17	10.75	5.00	11.25	21.00

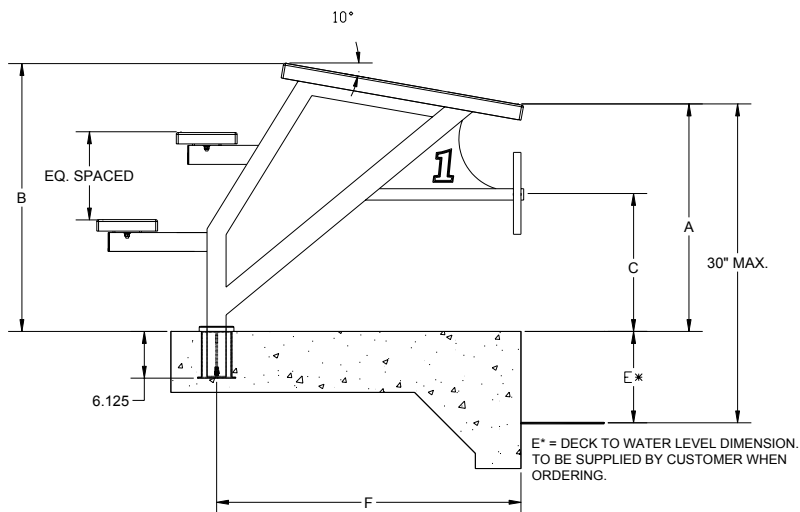

**FIGURE 2**

PART NUMBER	A	B	C	F*
Legacy 30-30 thru 40-30	30	35.00	18.00	30 thru 40
Legacy 30-29.5 thru 40-29.5	29.5	34.50	17.50	30 thru 40
Legacy 30-29 thru 40-29	29	34.00	17.00	30 thru 40
Legacy 30-28.5 thru 40-28.5	28.5	33.50	16.50	30 thru 40
Legacy 30-28 thru 40-28	28	33.00	16.00	30 thru 40
Legacy 30-27.5 thru 40-27.5	27.5	32.50	15.50	30 thru 40
Legacy 30-27 thru 40-27	27	32.00	15.00	30 thru 40
Legacy 30-26.5 thru 40-26.5	26.5	31.50	14.50	30 thru 40
Legacy 30-26 thru 40-26	26	31.00	14.00	30 thru 40
Legacy 30-25.5 thru 40-25.5	25.5	30.50	13.50	30 thru 40
Legacy 30-25 thru 40-25	25	30.00	13.00	30 thru 40
Legacy 30-24.5 thru 40-24.5	24.5	29.50	12.50	30 thru 40
Legacy 30-24 thru 40-24	24	29.00	12.00	30 thru 40
Legacy 30-23.5 thru 40-23.5	23.5	28.50	11.50	30 thru 40
Legacy 30-23 thru 40-23	23	28.00	11.00	30 thru 40
Legacy 30-22.5 thru 40-22.5	22.5	27.50	10.50	30 thru 40
Legacy 30-22 thru 40-22	22	27.00	10.00	30 thru 40
Legacy 30-21.5 thru 40-21.5	21.5	26.50	9.50	30 thru 40
Legacy 30-21 thru 40-21	21	26.00	9.00	30 thru 40
Legacy 30-20.5 thru 40-20.5	20.5	25.50	8.50	30 thru 40
Legacy 30-20 thru 40-20	20	25.00	8.00	30 thru 40

\* In 2" Increments

# LEGACY STARTING PLATFORM PARTS LIST

ITEM NO.	QTY.	PART NO.	DESCRIPTION
1	1	27-107	WEDGE ANCHOR ASSY-SINGLE POST PLAT.
2	1	LEGACY FRAME	LEGACY STARTING PLATFORM FRAME
3	1	8-617B	FOOTBOARD, 24" X 30" LEGACY-FINISHED
4	1	74-228-2282	PLATFORM 8 X 12 (STEP)
5	4	5-138	1/2-13X2" FLAT SOC S/S
6	4	05-32-111	3/8" NYLON PROTECTIVE WASHER
7	4	5-145	3/8" FLAT WASHER S/S
8	4	5-151	3/8" LOCK WASHER, SPLIT S/S
9	4	5-139	3/8-16 HEX NUT S/S
10	4	05-616	1/2"X1-1/2"RD NYLON WASHER
11	4	05-14-114	1/2" FLAT WASHER S/S
12	4	05-14-115	1/2" LOCK WASHER S/S
13	4	05-14-116	1/2" HEX NUT S/S
14	1	EP-300	ESCUTCHEON, SQUARE 2.5" X 2.5"

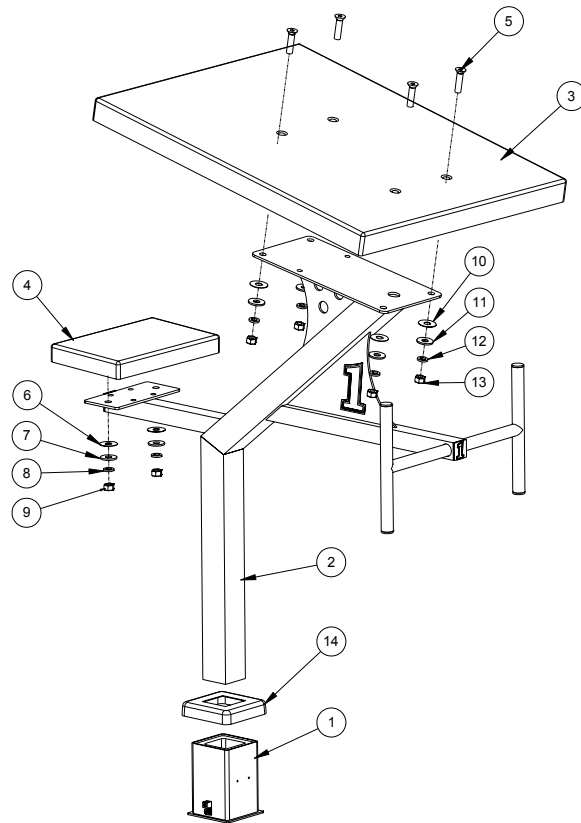

FIGURE 3

## LEGACY LONG REACH STARTING PLATFORM PARTS LIST

ITEM NO.	QTY.	PART NO.	DESCRIPTION
1	1	27-107	WEDGE ANCHOR ASSY-SINGLE POST PLAT.
2	1	LEGACY FRAME	LEGACY STARTING PLATFORM FRAME
3	1	8-623B	FOOTBOARD, 24" X 32" LEGACY-FINISHED
4	2	74-228-2283	PLATFORM 8 X 12 (STEP)
5	4	5-138	1/2-13X2" FLAT SOC S/S
6	8	05-616	1/2"X1-1/2"RD NYLON WASHER
7	8	05-14-114	1/2" FLAT WASHER S/S
8	8	05-14-115	1/2" LOCK WASHER S/S
9	8	05-14-116	1/2" HEX NUT S/S
10	1	EP-300	ESCUTCHEON, SQUARE 2.5" X 2.5"

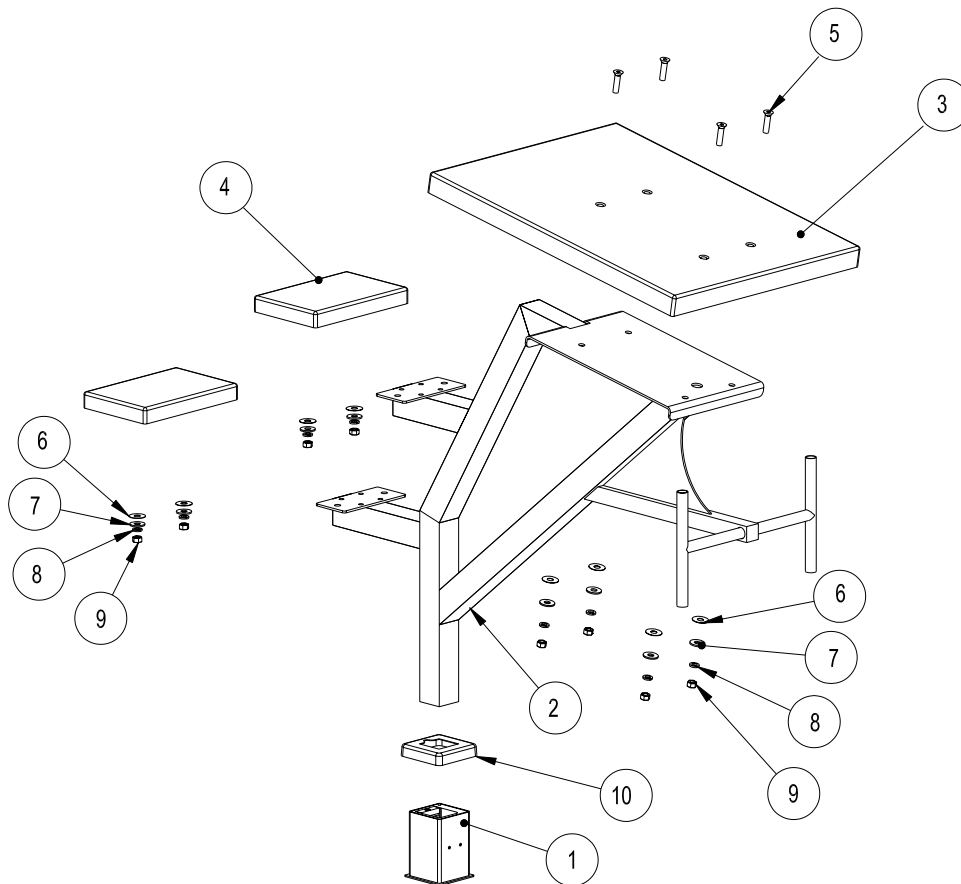
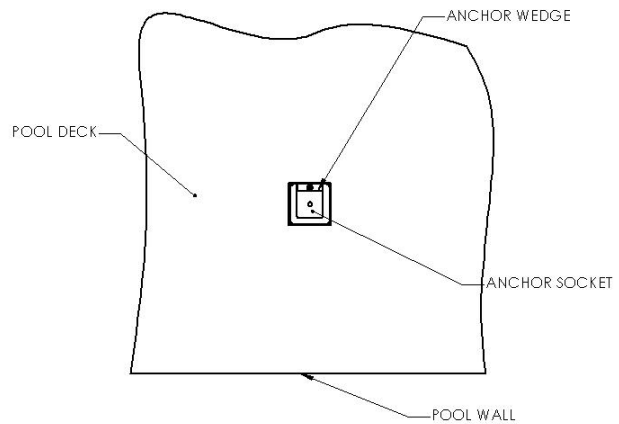

FIGURE 4

# LEGACY INSTALLATION

The Legacy Starting Platform anchor can be installed in an existing pool deck or set when pouring a new concrete deck.

1. The wedge anchor should be installed in the orientation shown in **FIGURE 5**. As shown in **FIGURE 5**, the side of the anchor that contains the wedge should be oriented such that it is parallel to, and farthest away from, the pool wall.
2. The setback for the anchor must be set using the correct distance "F" from the pool wall and with at least 6" from any control joint or edge of concrete slab. The correct setback distance depends on the model ordered. When the starting block is installed, the backstroke handles and leading edge of the footboard shall be flush with the pool wall. Refer to **FIGURES 6 & 7**.
3. Core drill at least a 6 1/2-inch diameter hole at the chosen location for the anchor if installing the mounting anchor into an existing deck. If the deck is new construction the anchor shall be braced so it is not moved from its proper position during pouring of the deck.
4. Properly ground the anchor socket using the attached grounding lug and the appropriate grounding wire per local codes. If electrical bonding is required by the local governmental regulations, it shall be done in accordance with Article No. 680 of the current National Electrical Code or the local code whichever is greater.
5. With the anchor completely checked for level and plumb in the selected position, pour hydraulic cement or high strength epoxy into the hole making sure there are no void spaces if installing in an existing deck. If installation is new construction, ensure anchor is in its proper location and square to the pool wall before pouring concrete.
6. Let cement/grout cure for 24 hours (or minimum manufacture's recommendations) before using starting platform.



**FIGURE 5**

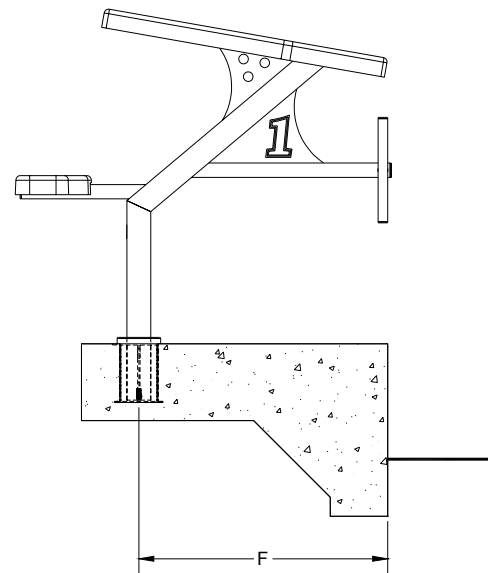

**FIGURE 6**

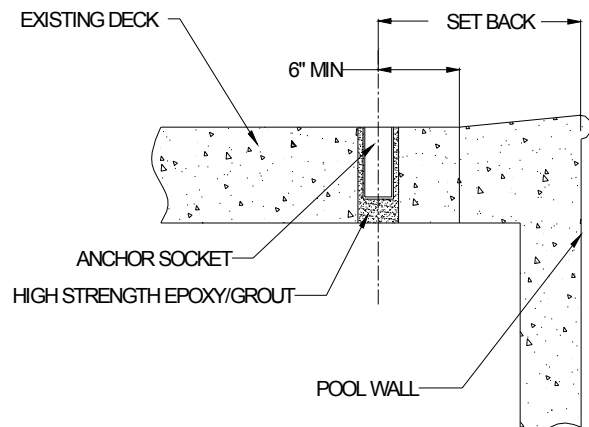
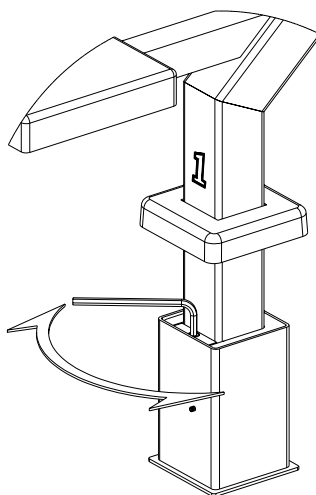

**FIGURE 7**

## STARTING PLATFORM INSTALLATION AND REMOVAL:

When placing a starting platform into an anchor it's important to follow these simple instructions.

1. Loosen bolt using a ¼" ALLEN wrench, turning wrench in a counter-clockwise direction as seen from looking down. See **FIGURE 8**.
2. Make sure that the opening size directly adjacent to anchor bolt is between 2-9/16" (65mm) and 2-5/8" (66.7mm) wide. The opening in this direction should never exceed 2-5/8" (66.7mm) or the anchor will disassemble!
3. Place escutcheon over starting platform frame tube orienting as shown. For the long reach model make sure the escutcheon is orientated with the notch directly over the anchor bolt.
4. Place starting platform into anchor making sure that the platform frame rests completely on the bottom of the anchor and the forward edge of the starting platform faces the pool edge.
5. Tighten ALLEN wrench in the clockwise direction until anchor wedge contacts the starting platform frame and no forward or backward motion can be felt. When tightening anchor wedge, never exceed 8 Ft-Lbs of torque. Anchor bolt should be snug but never over tightened.



**FIGURE 8**

6. To remove starting platform, lift escutcheon, insert ALLEN wrench into anchor bolt and turn counter-clockwise two (2) full turns. For long reach models the anchor bolt is accessed through the notch in the escutcheon. Lift and remove starting platform. DO NOT continue to loosen anchor bolt or remove anchor bolt for any reason.

### **SAFETY & MAINTENANCE INSTRUCTIONS**

- **Execute shallow racing dives only.**
- For use by trained competitive swimmers only.
- Periodically inspect the Legacy Starting Platform to assure there are no worn parts and that all hardware is properly tightened.
- All stainless steel parts require periodic maintenance. Polishing with a cotton cloth and a Windex-type product maintains the finish and restores luster.
- Use non-abrasive soap and water. Avoid harsh chemicals and disinfectants. Always read the label instructions on any cleaner carefully before applying it to a surface.