

THE AquaBlast™ & RocketRide™ FUNSLIDES™

ASSEMBLY AND INSTALLATION INSTRUCTIONS



*** * CAUTION * ***

S.R. SMITH AquaBlast™ & RocketRide™ FUNSLIDES™ ARE MANUFACTURED FOR INSTALLATION AND USE ON RESIDENTIAL INGROUND POOLS ONLY. AquaBlast™ & RocketRide™ FUNSLIDES™ ARE NEVER TO BE INSTALLED AND USED ON PUBLIC INGROUND POOLS, ABOVEGROUND POOLS, ONGROUND POOLS, HOUSEBOATS, BOAT DOCKS, FLOATING DOCKS OR PLATFORMS.

**CORPORATE HEADQUARTERS
WESTERN SALES AND MANUFACTURING PLANT
P.O. Box 400 • 1017 SW Berg Parkway
Canby, Oregon 97013
Phone (503) 266-2231 • Fax (503) 266-4334**

**EASTERN MANUFACTURING PLANT
PORTLAND, TENNESSEE**

www.srsmith.com

Table of Contents

<u>Topic</u>	<u>Page #</u>
Introduction.....	2
Applicable Standards and Codes.....	2
Assembly and Installation.....	2
Drawings.....	2
Left Curve Footprint.....	3
Right Curve Footprint.....	3
Parts List (AquaBlast).....	4
AquaBlast Assembly Instructions	5
Parts List (RocketRide).....	9
RocketRide Assembly Instructions for In Deck Mounting.....	9
RocketRide Assembly Instructions for Flush Mounting.....	12
Water System/Plumbing Installation.....	13
Manufacturer's Placement Instructions.....	17
Installed Slide's Structural & Installation Checklist.....	19
Appendix A: AquaBlast™ Exploded View & Parts List.....	20
Appendix B: RocketRide™ Exploded View & Parts List.....	21

INTRODUCTION

S.R. Smith AquaBlast™ & RocketRide™ FunSlides™ are manufactured for installation and use on residential inground swimming pools only. S.R. Smith AquaBlast™ & RocketRide™ FunSlides™ are NEVER to be installed and used on public inground pools, aboveground pools, onground pools, houseboats, boat docks, floating docks or platforms.

APPLICABLE STANDARDS AND CODES

1. All S.R. Smith AquaBlast™ & RocketRide™ FunSlides™ are manufactured in accordance with Consumer Products Safety Commission STANDARD FOR SWIMMING POOL SLIDES, 16 CFR Ch. 11 Part 1207 (latest edition).
2. Installer must comply with all applicable governmental and building codes.

ASSEMBLY AND INSTALLATION

All S.R. Smith AquaBlast™ & RocketRide™ FunSlides™ are inspected prior to shipment from the factory. Proper assembly and installation is mandatory. Improper assembly and installation voids S.R. Smith's warranty and may affect the safety of the user. S.R. Smith cannot and does not guarantee customer's concrete deck.

DRAWINGS

All drawings in these Assembly and Installation Instructions (FIGURES 1 through 26) are for illustration purposes only and are NOT TO SCALE.

LEFT CURVE FOOTPRINT

The purpose of this footprint is to serve as a GUIDELINE ONLY for approximate placement of the slide relative to the pool's edge. The actual dimensions after installation may vary according to the slope of the deck and the angle that the slide is oriented relative to the pool wall.

YOU MUST FOLLOW THE INSTALLATION INSTRUCTIONS AS PRINTED IN THIS MANUAL.

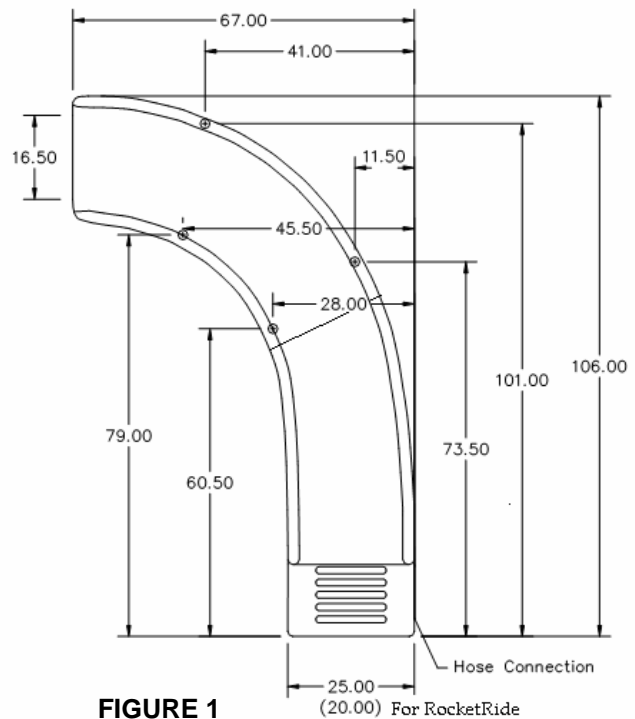

FIGURE 1

RIGHT CURVE FOOTPRINT

The purpose of this footprint is to serve as a GUIDELINE ONLY for approximate placement of the slide relative to the pool's edge.

The actual dimensions after installation may vary according to the slope of the deck and the angle that the slide is oriented relative to the pool wall.

YOU MUST FOLLOW THE INSTALLATION INSTRUCTIONS AS PRINTED IN THIS MANUAL.

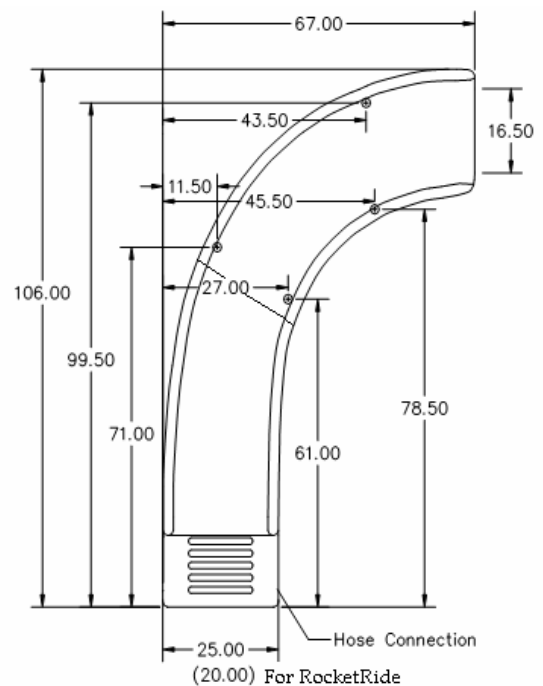

FIGURE 2

LEFT CURVE SLIDE WITH FLUSH DECK MOUNTING

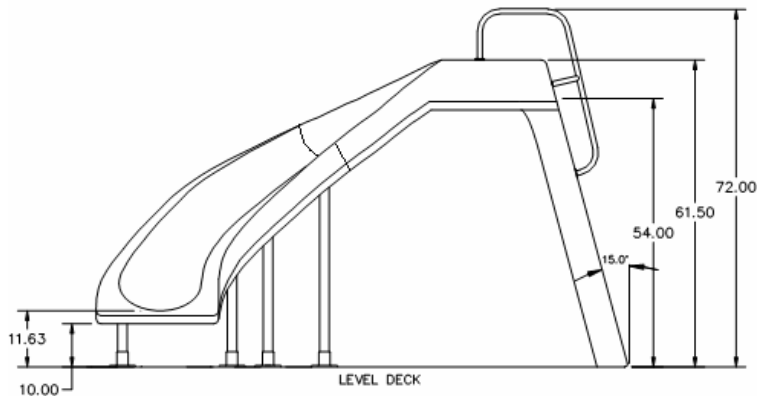

FIGURE 3

The purpose of this side view is to serve as a GUIDELINE ONLY for approximate placement of the slide relative to the deck. The actual dimensions after installation may vary according to the slope of the deck and the angle that the slide is oriented relative to the pool wall. The AquaBlast™ Slide is to be deck mounted. The RocketRide™ can be either mounted on the deck or in the deck. When installing the RocketRide™ Slide in the deck, these dimensions will be reduced by at least 3-1/8 inches.

AquaBlast™ Parts List

Ref # *	PART #	DESCRIPTION	QTY.
1	05-14-110	1/2" x 1-1/4" Fine Thread Bolt Grade 5	2 ea.
2	05-14-115	1/2" Lock Washer S/S	6 ea.
3	05-14-114	1/2" x 1-3/8" Flat Washer S/S	6 ea.
4	05-14-116	1/2" Hex Nut S/S	2 ea.
5	05-32-122	1/2" Lag Bolt	2 ea.
6	05-32-123	1/2" Lead Expansion Shield	2 ea.
7	05-31-110	5/16" x 1" Hex Washer Head Tek Screw	4 ea.
8	5-149	1/4" Lock Washer S/S	2 ea.
9	05-137	1/4-20 Hex Nut S/S	2 ea.
10	05-144	1/4" -20UNC x 2-1/2" Stud w/ Nut and Flat Washer	16 ea.
11	05-14-111	1/4" x 5/8" Flat Washer S/S	10 ea.
12	05-14-117	1/4" Hex Lock Nut	4 ea.
13	05-14-123	1/4" -20 UNC x 2-3/4" Hex Head Cap Screw	4 ea.
14	01-500	3/8" O.D. Aluminum Bushing	4 ea.
15	75-209-5000	Aluminum Deck Anchor Flange	4 ea.
16	09-700	Thread Locking Compound	2 ea.
17	5-365	5/16 Hex Jam Nut S/S	6 ea.
18	5-303	5/16 Flat Washer S/S	12 ea.
19	5-306	5/16 Lock Washer S/S	6 ea.
20	5-316	5/16-18 X 1-1/2" HHCS	6 ea.
21	05-14-131	1/4" Split Lock Washer	16 ea.
22	06-691	AquaBlast™ & RocketRide™ Slide Assembly & Installation Instructions	1 ea.
23	06-692	AquaBlast™ & RocketRide™ Slide Owner's Manual	1 ea.

* Ref #s are shown as (#__) in these ASSEMBLY AND INSTALLATION INSTRUCTIONS

AquaBlast™ ASSEMBLY INSTRUCTIONS

1. Remove the slide runway parts from its packaging and place upside down on a surface that will not scratch the slide. Place the runway parts in the orientation shown in Figure 4.



FIGURE 4

2. Locate the (#20) 5/16-18 X 1-1/2 inch bolts, (#18) flat washers, (#19) lock washers and the (#17) hex nuts in the hardware package. Align the center hole in the flanges of the two runway parts. Use a pair of vise grips to hold the parts together. Place a (#18) flat washer onto a (#20) bolt and insert through the center holes of the runway joint flange. Place a (#18) flat washer, (#19) lock washer and (#17) nut onto the bolt as shown in Figure 5. Do not tighten the bolts completely at this point. Repeat this step for all remaining flange holes.

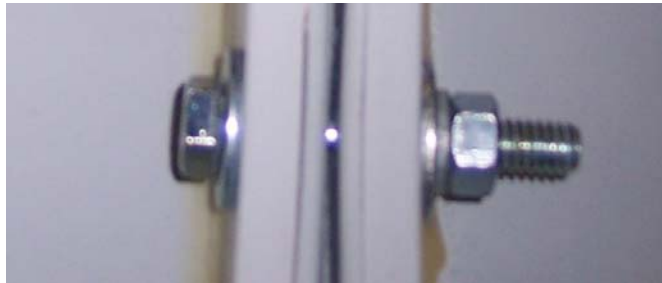

FIGURE 5

3. Once the all of the bolts have been inserted into the runway joint flange, the next step is to align the runway and tighten the bolts. Remove the vise grips and realign the parts so that the runway surface is even. Reattach the vise grips to hold the parts in place and finish tightening the runway flange bolts. See Figure 6.



FIGURE 6

4. Locate the 4 stainless steel legs. Secure at end of each leg a (#15) Aluminum Deck Anchor Flange by inserting a (#13) 1/4" x 2-3/4" Hex Head Cap Screw with a (#11) 1/4" x 5/8" Flat Washer through the flange and fasten with a (#11) 1/4" x 5/8" Flat Washer and a (#12) 1/4" -20UNC Hex Lock Nut. (see FIGURE 7)
NOTE: The (#14) Aluminum Bushing is not needed for flange installation on stainless steel legs.

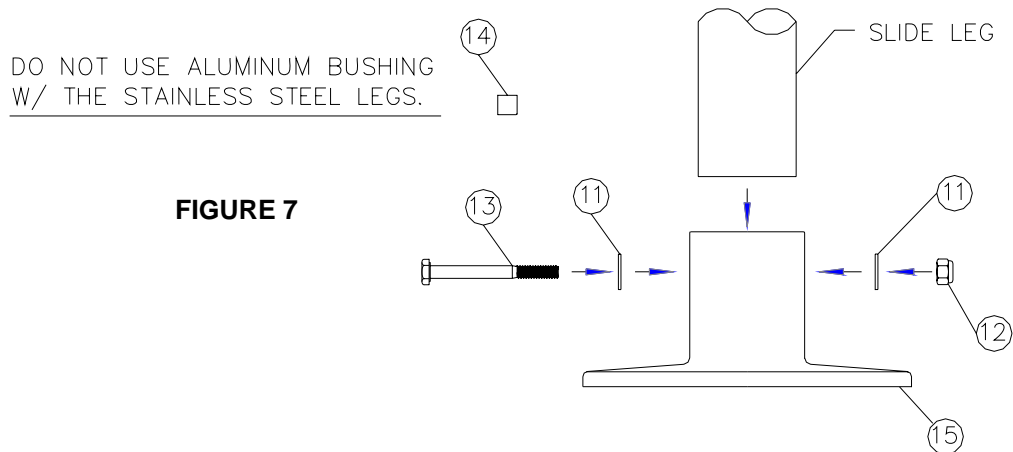

5. Insert the slide legs into the leg sockets of the slide. Do not attach the legs permanently at this point.
6. Carefully turn the slide with the legs in place upright for setup. It will be necessary for two people to perform this to avoid damage to the slide and the legs. If necessary use something such as tape to temporarily hold the legs in place while turning the slide over.
7. Bring the ladder into position under the slide and secure with two (#3) 1/2" x 1-3/8" Flat Washers, two (#2) 1/2" Lock Washers and two (#4) 1/2" Hex Nuts. (see FIGURE 8)

FIGURE 8

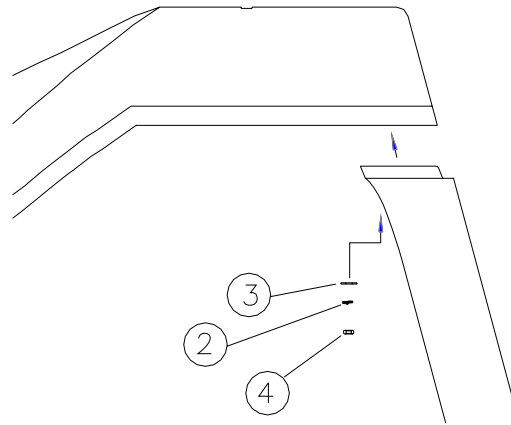

8. Place the slide at the desired location relative to the pool wall. See Manufacturer's Installation Criteria on Pages 16, 17 & 18. Also see ANSI/NSPI-5 2003 STANDARD FOR RESIDENTIAL INGROUND SWIMMING POOLS.
9. Level as close as possible the exit runway surface horizontally from side to side. Also ensure the top runway surface is level from side to side. (see FIGURE 9) If necessary the legs can be adjusted up or down within the leg sockets to help adjust for level. Once the slide is properly leveled the legs shall be permanently attached by drilling a 1/4" hole into each leg using the hole in the leg socket as a guide and fastening with a (#7) 5/16" x 1" Hex Washer Head Tek Screw.

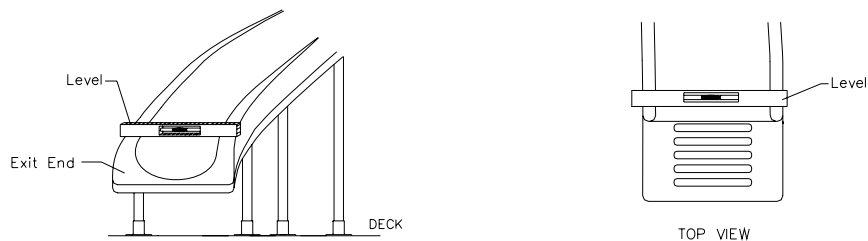

FIGURE 9

10. Ensure that the exit runway surface does not exceed 20 inches above the water surface, nor less than 8 inches above the deck/coping surface. (see FIGURE 23 page 16) The exit runway surface is measured at the point of transition between the runway and the beginning of the exit end radius.
11. Re-check the slide to ensure it is properly leveled and in its proper position. Make sure the legs are vertical before proceeding to the next step.
12. Using the four holes in each (#15) Aluminum Deck Anchor Flange and the holes in the base of the ladder as a template, mark the drill locations for the anchors. Move the slide to the side to facilitate drilling of the anchor holes.
13. Using the marked locations drill four 1/4" diameter holes per flange 1-3/8" deep. CAUTION: Do not drill holes larger than 1/4". Maintain drill hole straight and perpendicular for proper holding strength of anchor stud. For the holes marked at the base of the ladder drill 3/4" holes 2" deep, then insert a (#6) 1/2" Lead Expansion Shield into each hole.

14. Move the slide back to its proper position, then use a hammer to drive the (#10) 1/4"-20UNC x 2-1/4" Anchor Studs with a (#10) 1/4" x 5/8" Flat Washer, a (#21) 1/4" Lock Washer and a (#10) 1/4" Hex Nut on top into each hole of the (#15) Aluminum Deck Anchor Flanges leaving 7/8 of an inch of the stud above the deck. Next tighten the nut until it contacts the flange. Then, tighten the nut approximately three turns to set the anchor stud.
15. Secure the ladder to the deck by inserting the (#5) 1/2" Lag Bolts with a (#3) 1/2" x 1-3/8" Flat Washer and a (#2) 1/2" Lock Washer into the lead expansion shield. Tighten until the lock washers are compressed.

ELECTRICAL BONDING

If electrical bonding is required by the local governmental regulations, it shall be done in accordance with Article NO. 680 of the current National Electrical Code, or the local Code, whichever has jurisdiction.

16. Install the handrails by inserting each handrail into the holes in the top of the runway and securing with the (#9) 1/4-20 Hex Nuts, the (#8) 1/4" Lock Washers and the (#11) 1/4" x 5/8" Flat Washers. Attach the handrail to the ladder by securing with the (#3) 1/2" x 1-3/8" Flat Washers, (#2) 1/2" Lock Washers and the (#1) 1/2" Fine Thread Bolts. (see FIGURE 10) Do not over tighten. Note: Use the (#17) Thread Locking Compound on all bolts used to attach the handrail to the slide.

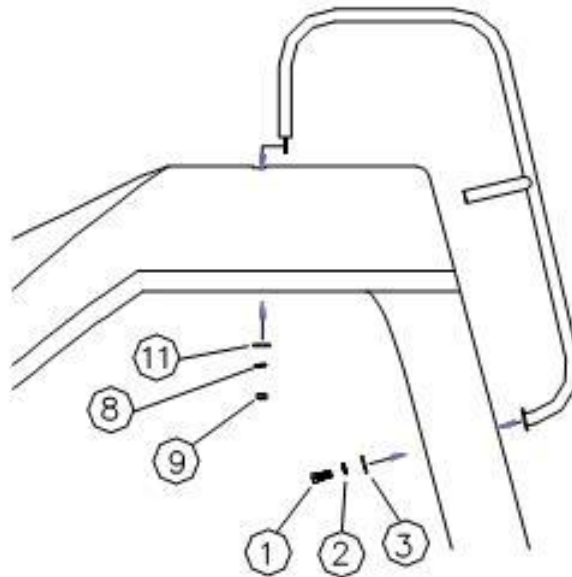

FIGURE 10

RocketRide™ PARTS LIST

Ref # *	PART #	DESCRIPTION	QTY.
1	5-365	5/16 Hex Jam Nut S/S	6 ea.
2	5-303	5/16 Flat Washer S/S	12 ea.
3	5-306	5/16 Lock Washer S/S	6 ea.
4	5-316	5/16-18 X 1-1/2" HHCS	6 ea.
5	05-767	Hose Clamp 1"	4 ea.
6	5-371	Screw, Self Tap #10-16	4 ea.
7	05-668	Bolt Cap .172 ID X .5 Long	4 ea.
8	69-209-083	RocketRide Handrail	2 ea.
9	05-31-110	5/16" x 1" Hex Washer Head Tek Screw	4 ea.
10	05-616	1/2" x 1-1/2" Round Nylon Washer	2 ea.
11	05-14-114	1/2" Flat Washer S/S	2 ea.
12	05-14-115	1/2" Lock Washer S/S	2 ea.
13	05-14-116	1/2" Hex Nut S/S	2 ea.
14	09-700	Thread Locking Compound	2 ea.
15	05-14-111	1/4" x 5/8" Flat Washer	14 ea.
16	05-14-117	1/4" Hex Lock Nut	4 ea.
17	5-149	1/4" Lock Washer S/S	6 ea.
18	05-137	1/4"-20 Hex Nut S/S	6 ea.
19	05-14-124	1/4" x 1/2" Sheet Metal Screw	5 ea.
20	05-143	1/4" x 3/4" Flat Washer C/S	5 ea.
21	05-154	1/4" -20 x 8" Carriage Bolt	4 ea.
22	06-623**	Plastic Deck Anchor Flange	4 ea.
23	05-144	1/4 " x 2-1/2" Anchor Stud w/ Nut and Washer	20 ea.
24	05-14-117	1/4" Hex Lock Nut	4 ea.
25	05-14-123	1/4" -20 UNC x 2-3/4" Hex Head Cap Screw	4 ea.
26	01-500	3/8" O.D. Aluminum Bushing	4 ea.
27	05-14-131	1/4" Split Lock Washer Zinc Plated	20 ea.
28	6-121	Nylon Tube Connector	4 ea
29	6-123	Nylon Handrail Connector	4 ea
30	01-212	Aluminum Handrail Spacer	4 ea
31	01-210	Aluminum Ladder Spacer	4 ea
32	06-691	AquaBlast™ & RocketRide™ Assembly & Installation Instructions	1 ea.
33	06-692	AquaBlast™ & RocketRide™ Slide Owner's Manual	1 ea.

* Ref #s are shown as (#__) in these ASSEMBLY AND INSTALLATION INSTRUCTIONS

** Deck anchor flanges are available in plastic (05-623) or aluminum (75-209-5000).

RocketRide™ ASSEMBLY INSTRUCTIONS FOR IN-DECK MOUNTING

1. Assemble the runway parts as outlined in steps1-3 of the AquaBlast™ assembly instructions (Page 5).

2. Open the ladder and parts carton and locate the ladder and the 4 legs.

3. Attach the slide ladder to the slide by using the (#10) 1/2" x 1-1/2" Nylon Washers, (#11) 1/2" Flat Washers, (#12) 1/2" Lock Washers, and the (#13) 1/2" Hex Nuts. Do not tighten completely at this point. NOTE: Make sure to place the nylon washers between the aluminum bracket and the stainless steel washers.
4. Insert the slide legs into the leg sockets of the slide. Do not attach the legs permanently at this point.
5. Carefully turn the slide with the legs and ladder upright for setup. It will be necessary for two people to perform this to avoid damage to the slide and the legs. If necessary use something such as tape to temporarily hold the legs in place while turning the slide over.
6. Place the slide at the desired location relative to the pool wall. See MANUFACTURER'S PLACEMENT INSTRUCTIONS on pages 16, 17 & 18.
7. Ensure that the exit runway surface does not exceed 20 inches above the water surface, nor less than 8 inches above the deck/coping surface (see FIGURE 23 page 16). The exit runway surface is measured at the point of transition between the runway and the beginning of the exit end radius.
8. Ensure that the ladder is not twisted relative to the slide.
9. Insert 3/8" diameter rebar (not provided) into the holes located at the bottom of each leg making sure that the rebar will be a minimum of three inches (3") below the deck surface.
10. Install electrical bonding as local code specifies (see ELECTRICAL BONDING page 12).
11. Secure the ladder so that the ladder steps are level, from side to side, and the ladder is sloped 15 degrees from vertical (see FIGURE 3 page 4).
12. Adjust the top runway of the slide so that it is level, from side to side as shown in FIGURE 11.

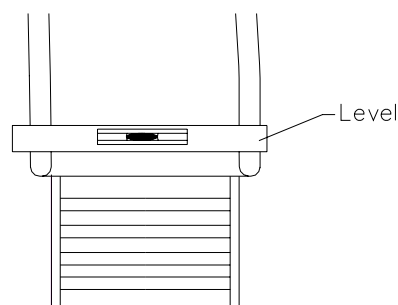

TOP VIEW

FIGURE 11

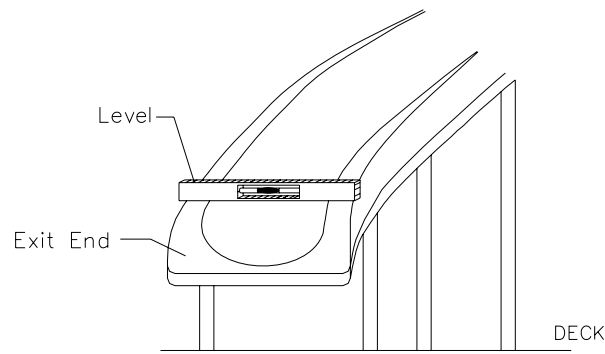

FIGURE 12

13. Level as close as possible the exit runway surface horizontally from side to side. (see FIGURE 12)
14. If necessary the legs can be adjusted up and down within the leg sockets to help adjust for level. Once the slide is properly leveled the legs shall be permanently attached by drilling a 1/4" hole into each leg using the hole on the leg socket as a guide and fastening with a (#9) 5/16" Hex Head Washer Head Tek Screw.
15. Install the handrails by inserting each handrail into the holes in the top of the runway and securing with the (#18) 1/4"-20 Hex Nut S/S, the (#17) 1/4" Lock Washers and the (#15) 1/4" x 5/8" Flat Washers. (See FIGURE 13a) Note: Use the (#14) Thread Locking Compound on all bolts used to attach the handrail to the slide.

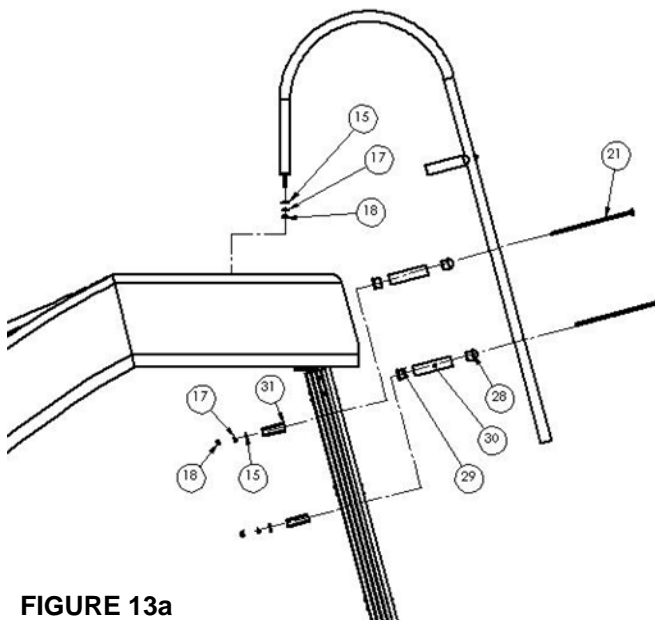

FIGURE 13a

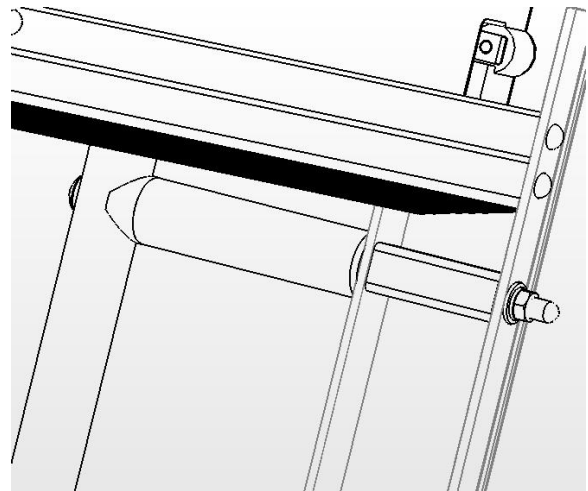

FIGURE 13b

16. Attach the handrails to the ladder using the (#21) Carriage Bolts, the (#30) Handrail Spacer, the (#31) Ladder Spacer, the (#17) 1/4" Lock Washers, the (#15) 1/4" x 5/8" Flat Washers, and the (#18) 1/4"-20 Hex Nuts. (See FIGURES 13a and 13b) Do not over tighten. The (#31) ladder spacer is to be positioned inside of the ladder side channel as shown in Figure 13b. Note: Use the (#14) Thread Locking Compound on all bolts used to attach the handrail to the ladder.
17. Repeat this procedure for installation of the second handrail.

18. Use a drill with a Phillips bit to fasten the (#5) Plastic hose Clamp to the ladder with a (#6) self tapping screw as shown below in Figure 14a. The hose clamp should be attached with the clamp aligned with the bottom of the step, See Figure 14b. Place (#7) Vinyl Cap over visible portion of screw. Repeat this step for each tread on ladder.



FIGURE 14a



FIGURE 14b

19. Secure the slide, so that it will not move during the concrete pour, to ensure that the settings remain the same.
20. SUGGESTION: To ensure easy removal of concrete from legs and ladder, wax or wrap with wax paper approximately 12 inches above deck level.
21. Proceed with pouring the concrete deck and finish as desired. Let concrete cure 24 hours before using slide.

ELECTRICAL BONDING

If electrical bonding is required by the local governmental regulations, it shall be done in accordance with Article No. 680 of the current National Electrical Code or the local Code, whichever has jurisdiction. Five (#19) 1/4" x 1/2" Sheet Metal Screws and five (#20) 1/4" x 3/4" Flat Washers are provided for this purpose. Secure one per slide leg and one per ladder.

RocketRide™ ASSEMBLY INSTRUCTIONS FOR FLUSH DECK MOUNTING

The following instructions are for mounting a slide on an existing deck.

1. Follow the steps listed on pages 9, 10, and 11 for in-deck mounting, as they are the same with the exception of the attachment of the deck anchor flanges. NOTE: Rebar will not be used.
2. Place a deck anchor flange over each end of the slide legs.

3. Using the four holes on each flange as a template (see FIGURE 15 below), drill four 1/4" holes per flange 1-3/8" deep. CAUTION: Do not drill holes larger than 1/4". Maintain drill hole straight and perpendicular for proper holding strength of anchor stud.

4. Raise the flange up the leg and secure in place while using a hammer to drive the (#23) 1/4"-20UNC x 2-1/4" Anchor Studs with a (#23) 1/4" x 5/8" Flat Washer, a (#27) 1/4" Lock Washer and a (#23) 1/4" Hex Nut on top into each hole of the (#22) Plastic Deck Anchor Flanges leaving 7/8 of an inch of the stud above the deck. Next tighten the nut until it contacts the flange. Then, tighten the nut approximately three turns to set the anchor stud.

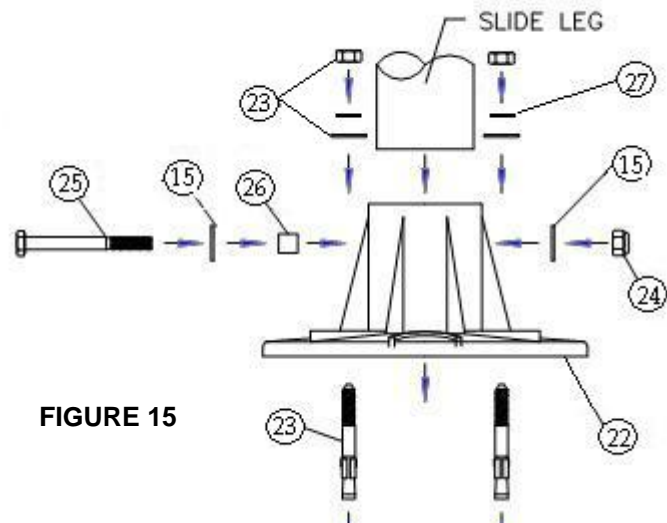

FIGURE 15

5. Using the two holes on each ladder feet as templates, drill holes 1/4" diameter by 1-3/4 inches deep and secure (#23) Anchor Studs as described in 3 & 4 above.

6. Secure the two ladder feet with (#23) 1/4" x 5/8" Flat Washers, (#27) 1/4" Lock Washers and (#23) 1/4" Hex Nuts. Be sure that the ladder maintains 15 degrees from vertical.

7. Drill a 1/4" diameter hole into the slide leg through the 3/8" diameter hole in the flange. Insert the (#26) 3/8" O.D. Aluminum Bushing into the hole in the deck flange and push in until it contacts the slide leg. Now insert the (#25) 1/4"-20UNC x 2-3/4" Hex Head Cap Screws and (#15) 1/4" x 5/8" Flat Washers through the bushing and in about a 1/2" into the hole in the slide leg. With the cap screw in position, drill a 1/4" hole into the slide leg through the 5/16" diameter hole in the opposite side of the deck flange. Take care not to run the drill bit into the 1/4" bolt. Push the cap screw completely through the slide leg. Install the (#15) 1/4" x 5/8" Flat Washers and (#16) 1/4"-20UNC Hex Lock Nuts (see FIGURE 15)

WATER SYSTEM/PLUMBING INSTALLATION

69-209-077 AquaBlast™/RocketRide™ Hose Kit

Ref # *	PART #	DESCRIPTION	QUANTITY
1	05-765	Elbow, ST 1" SCH 40 PVC	1 ea.
2	05-766	Valve Ball PVC SCH 80 1"	1 ea.
3	05-769	Union PVC SCH 40 1"	1 ea.
4	05-772	Thread Adapter SCH 40 PVC	1 ea.
5	05-771	Hose PVC Spa 1" SCH 40	1 ea.
6	05-773	Garden Hose Adapter	1 ea.

1. Apply a small amount of silicone sealant to the male thread side of the (#1) PVC 90° Elbow. Thread the elbow into the fitting in the bottom of the slide as shown below. Tighten until the elbow is snug and in the orientation shown in Figure 16.



FIGURE 16

2. Apply PVC glue to the male slip end of the (#4) PVC Thread Adapter and insert into one side of the (#3) PVC Union. Be sure to push the thread adapter as far as it will go into the union. See Figures 17a and 17b.



FIGURE 17a



FIGURE 17b

3. Apply a small amount of silicone sealant to the male threaded insert that was glued into the (#3) PVC Union in step 2. Thread the PVC Union into the elbow from step 1 and hand tighten until snug. See Figure 18.



FIGURE 18

4. Apply PVC glue to the inside of the slip end of the PVC Union. Insert the (#5) PVC Spa Hose into the union as shown below in Figure 19.



FIGURE 19

5. Thread the PVC union back together with the spa hose attached as shown in Figure 20.



FIGURE 20

6. Starting with the top hose clamp, insert the PVC hose into the clamps as shown below in Figure 21. The clamps automatically tighten when pressure is applied pushing the hose into the clamps.



FIGURE 21

7. Apply PVC glue to one socket of the (#2) PVC Ball Valve and insert the PVC hose into the valve as shown in Figure 22. Allow the glue sufficient time to dry. The final step is joining the PVC Ball Valve to the water source.



FIGURE 20

If connecting the AquaBlast™/RocketRide™ water system to the pool plumbing system is not an option you may connect the water system to a garden hose by following the steps outlined below.

8. Make sure that the AquaBlast™ RocketRide™ water system has been properly assembled as explained above. Next, apply PVC glue around the end of the garden hose adapter indicated by the arrow in Figure 21.

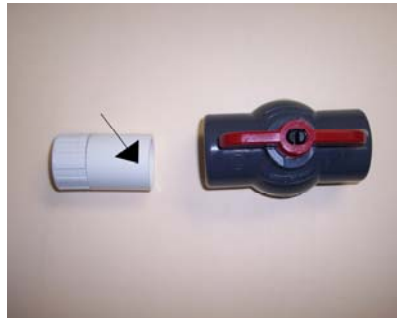

Figure 21

9. After the glue is applied quickly insert the PVC fitting into one end of PVC ball valve as shown in Figure 22.



Figure 22

10. The final step is to thread a garden hose into the PVC garden hose adapter.

MANUFACTURER'S PLACEMENT INSTRUCTIONS

1. The critical dimensions for placement of the slide are as shown in FIGURES 23 and 24.

- A. The slide exit runway surface shall not exceed twenty inches (20") above the water surface and not less than eight inches (8") above the deck/coping surface (see Figure 23).
- B. The slide shall be positioned so that all water flowing off the runway exit drops into the pool.
- C. The minimum depth of water below the exit lip of the slide shall be three feet (3') and increases to four feet six inches (4'-6") at Pt.A which is a distance of four feet six inches (4'-6") from the exit lip of the slide. (see FIGURE 23).
- D. A minimum depth of four feet six inches (4'-6") shall be maintained at a distance of nine feet (9') along the extended centerline of the slide from Pt.A. (see FIGURE 23).

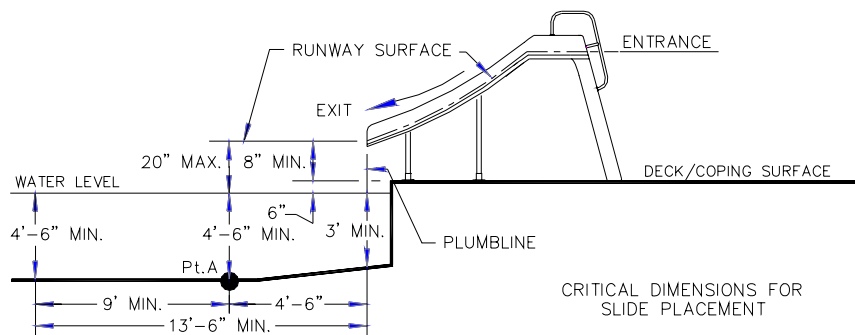

FIGURE 23

2. A minimum clearance area in front of the slide shall be maintained away from the coping, another slide, a diving board or a rope and float line. (see FIGURE 24)

- A. The minimum clearance distance on either side of the extended centerline of the slide runway shall not be less than three feet six inches (3'-6") at a point no less than two feet six inches (2'-6") from the exit of the slide and extending a distance of thirteen feet six inches (13'-6") in front of the slide. (see FIGURE 24)

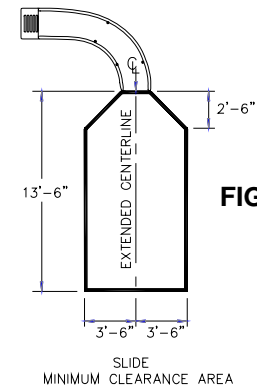

FIGURE 24

- B. The minimum clearance area in front of a diving board is a minimum distance of three feet six inches (3'-6") on either side of the board's centerline. Pt.C extends a minimum distance of "C" from the tip end of the board. The width distance "W" on either side of Pt.C is given in CHART 1 and shown in FIGURE 25.

CHART 1

BOARD MINIMUM CLEARANCE AREA		
POOL TYPE	"C" DIMENSION	"W" DIMENSION
I	14'-6"	5'-0"
II	14'-6"	6'-0"
III	16'-6"	6'-0"
IV	18'-6"	7'-6"
V	21'-0"	7'-6"

See Article 5 contained in ANSI/NSPI-5 2003 STANDARD FOR RESIDENTIAL INGROUND SWIMMING POOLS and refer to Figure 3 and Table 1 for Minimum Water Envelope Dimensions AB, BC and Width at Point C.

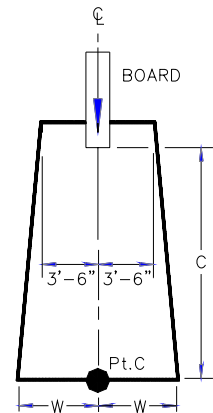

BOARD MINIMUM CLEARANCE AREA

"C" DIMENSION FOR BOARD = AB + BC
 "W" DIMENSION FOR BOARD = WIDTH AT PT.C

FIGURE 25

C. The minimum clearance area of a slide or diving board shall not intersect any coping or rope and float line. (see FIGURE 26) The minimum clearance area of a slide or diving board may intersect each other provided that they are not used simultaneously.

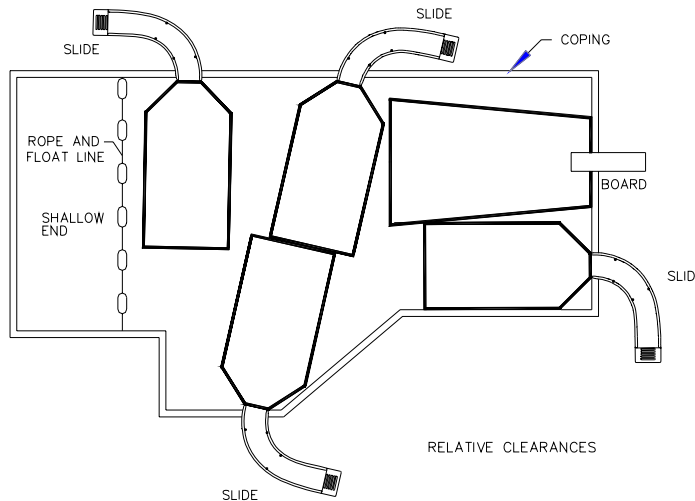

FIGURE 26

INSTALLED SLIDES' STRUCTURAL & INSTALLATION CHECKLIST

1. Inspect the runway for visible cracks or tears.
2. Inspect the slide for sharp edges, protrusions, cracks or tears.
3. Inspect all attachment flanges for loose or corroded fasteners.
4. For the Slinger Slide inspect all ladder tread or step-attachment points for evidence of shear, bending yield, or fatigue in the ladder steps, rails, or attachments means. Yield is evidenced by crystallization or fine cracking of the ladder tread and/or surface.
5. Inspect the ladder handrails for rigidity and attachment. (Can they be pulled out of their sockets?)
6. Measure the following dimensions and compare with the Manufacturer's Placement Instructions on pages 16, 17 and 18. Also review the ANSI/NSPI-5 2003 STANDARD FOR RESIDENTIAL INGROUND SWIMMING POOLS.
 - Measure the depth of water in front of the slide exit. (4-1/2' min. depth 4-1/2' from exit end of slide.)
 - Measure the height of the slide runway exit above the water. (20" max.)
 - Measure the distance between the slide centerline and the edge of other pool equipment.
7. Observe the position of the exit of the slide as shown in FIGURES 23, 24 and 25 on pages 16 and 17.

IMPORTANT

PERSONALLY GIVE TO SLIDE OWNER THE AquaBlast™ & RocketRide™ FUNSLIDE™ OWNER'S MANUAL, THE WARRANTY CARD AND ANSWER ALL QUESTIONS.

Appendix A: AquaBlast™ Exploded View and Parts List

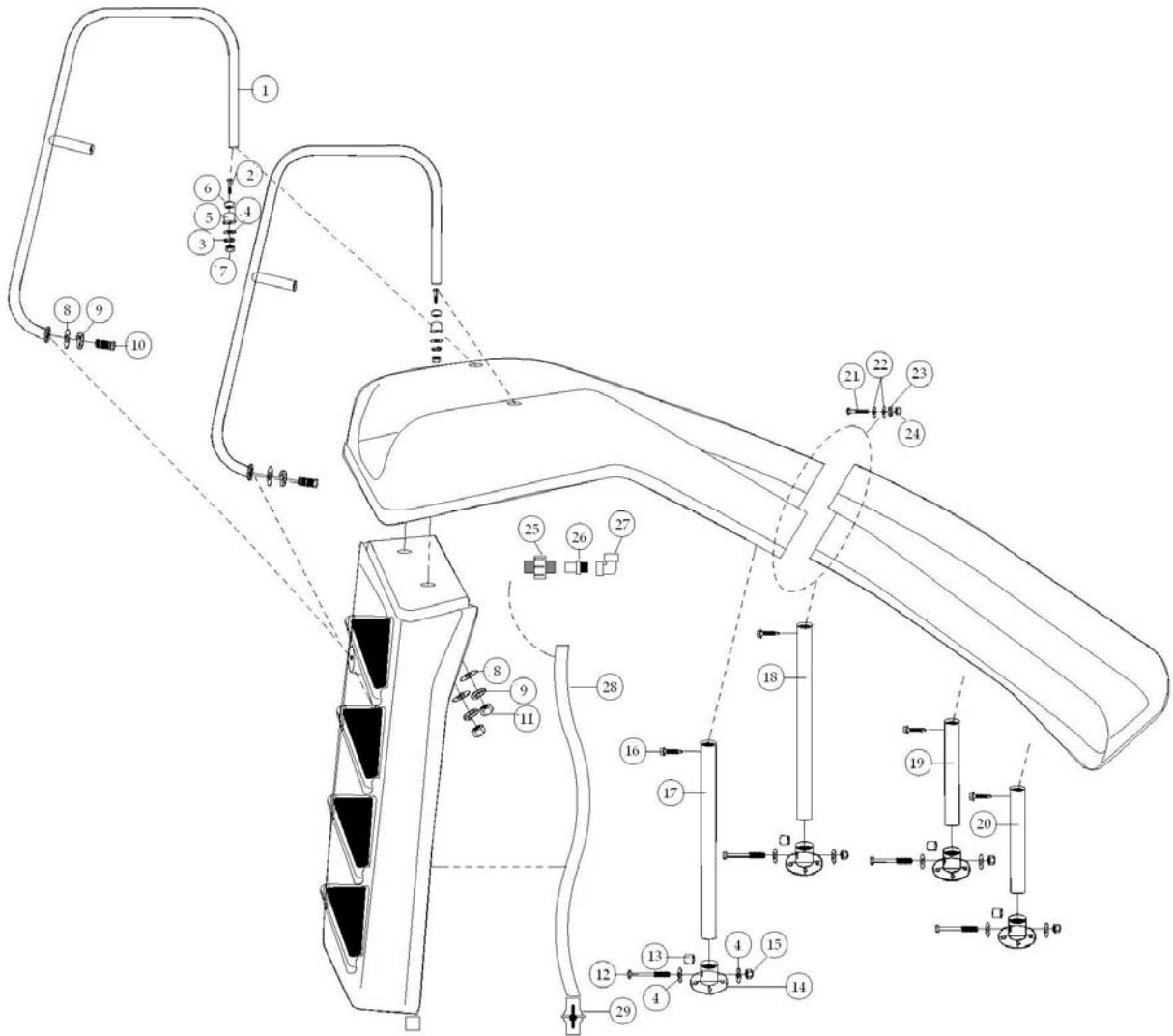

KEY	PART #	DESCRIPTION	KEY	PART #	DESCRIPTION
1	69-209-077	AquaBlast™ Handrail	16	05-31-110	5/16" x 1" Hex Washer Head Tek Screw
2	05-156	1/4" x 1-1/2 S/S HHCS	17	20-225	41" AquaBlast™ Slide Leg
3	5-149	1/4" Split Lock Washer S/S	18	20-224	42" AquaBlast™ Slide Leg
4	05-14-111	1/4" x 5/8" Flat Washer S/S	19	20-227	23" AquaBlast™ Slide Leg
5	6-123	Special Handrail Connector	20	20-226	24" AquaBlast™ Slide Leg
6	6-122	Nylon Wedge	21	5-316	5/16"-18 x 1-1/2 Hex Bolt S/S
7	05-137	1/4"-20 Hex Nut S/S	22	5-303	5/16" Flat Washer S/S
8	05-14-114	1/2" Flat Washer S/S	23	5-306	5/16" Split Lock Washer S/S
9	05-14-115	1/2" Lock Washer S/S	24	5-365	5/16"-18 Hex Nut S/S
10	05-14-110	1/2"-20 x 1-1/4 Hex Bolt S/S	25	05-769	Union PVC 1" SCH 40
11	05-14-116	1/2" Hex Nut S/S	26	05-772	Thread Adapter 1" SCH 40 PVC
12	05-14-123	1/4"-20 x 2-3/4 Hex Bolt S/S	27	05-765	Elbow ST 1" SCH 40 PVC
13	01-500	3/8" OD Aluminum Bushing	28	05-771	Hose PVC Spa 1"
14	75-209-5000	Aluminum Deck Anchor Flange	29	05-766	Valve PVC 1" SCH 80
15	05-14-117	1/4"-20 Hex Lock Nut S/S			

Appendix B: RocketRide™ Exploded View and Parts List

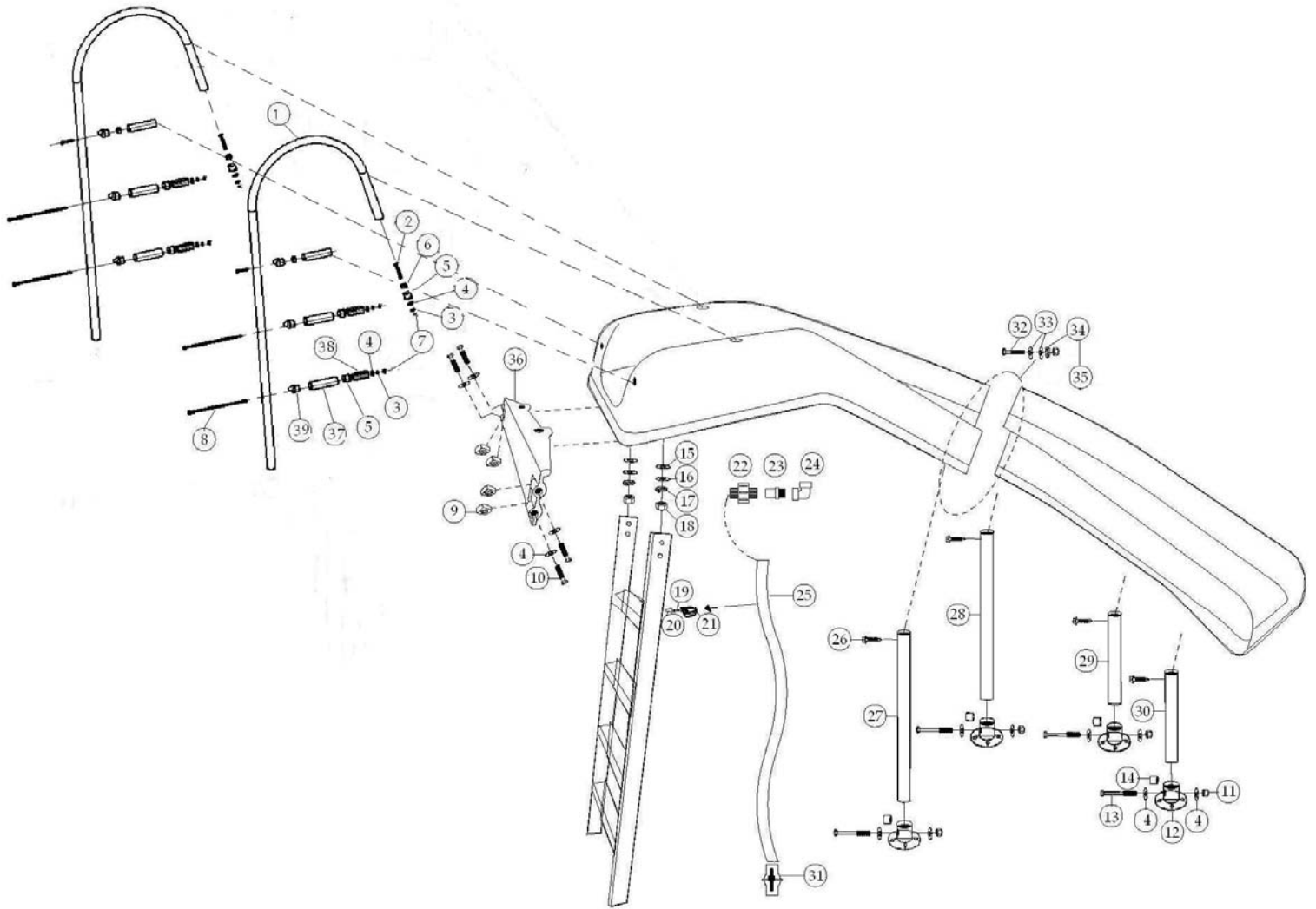

KEY	PART #	DESCRIPTION	KEY	PART #	DESCRIPTION
1	69-209-083	RocketRide Handrail	20	05-668	Bolt Cap .172" ID x .5" long
2	05-156	1/4" x 1-1/2 S/S HHCS	21	05-767	Plastic Hose Clamp 1"
3	5-149	1/4" Split Lock Washer S/S	22	05-769	Union PVC 1" SCH 40
4	05-14-111	1/4" x 5/8" Flat Washer S/S	23	05-772	Thread Adapter 1" SCH 40 PVC
5	6-123	Special Handrail Connector	24	05-765	Elbow ST 1" SCH 40 PVC
6	6-122	Nylon Wedge	25	05-771	Hose PVC Spa 1"
7	05-137	1/4"-20 Hex Nut S/S	26	05-31-110	5/16" x 1" Hex Washer Head Tek Screw
8	05-154	1/4"-20 x 6"	27	14-112	41" RocketRide Slide Leg
9	05-14-115	1/2" Lock Washer S/S	28	14-113	42" RocketRide Slide Leg
10	05-14-110	1/2"-20 x 1-1/4 Hex Bolt S/S	29	14-110	23" RocketRide Slide Leg
11	05-14-117	1/4"-20 Hex Lock Nut S/S	30	14-111	24" RocketRide Slide Leg
12	06-623	Plastic Deck Anchor Flange	31	05-766	Valve PVC 1" SCH 80
13	05-14-123	1/4"-20 x 2-3/4 Hex Bolt S/S	32	5-316	5/16"-18 x 1-1/2 Hex Bolt S/S
14	01-500	3/8" OD Aluminum Bushing	33	5-303	5/16" Flat Washer S/S
15	05-616	1/2" x 1-1/2 Round Nylon Washer	34	5-306	5/16" Split Lock Washer S/S
16	05-14-114	1/2" Flat Washer S/S	35	5-365	5/16"-18 Hex Nut S/S
17	05-14-115	1/2" Lock Washer S/S	36	01-400	Aluminum Ladder Adapter
18	05-14-116	1/2" Hex Nut S/S	37	01-212	Aluminum Handrail Spacer
19	5-371	#10-16 Self Tapping Screw	38	01-210	Aluminum Ladder Spacer