

# STA-RITE®

## MAX-E-PRO™ CENTRIFUGAL PUMPS WITH INTEGRAL TRAP

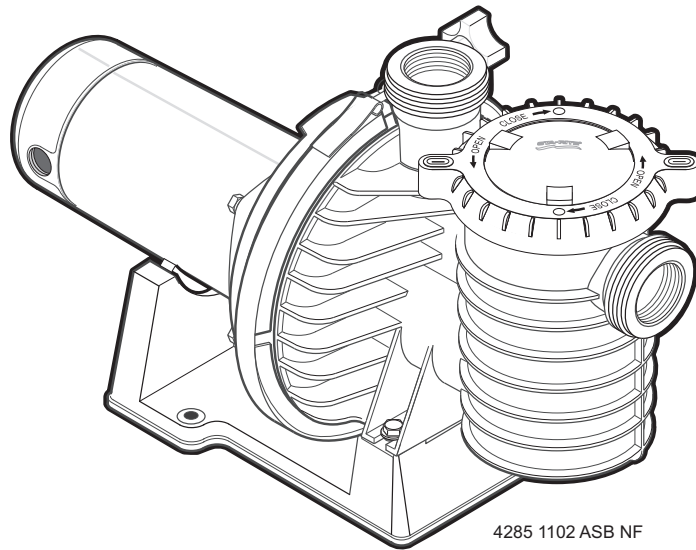

O W N E R ' S M A N U A L

INSTALLATION, OPERATION & PARTS

Series P6RA, P6EA, and P6E  
See Page 2 for Model Numbers

This manual must be given to the owner/user of this pump

**Pentair Water Pool and Spa, Inc.**

© 2007 Pentair Water Pool and Spa, Inc. All rights reserved.  
1620 Hawkins Ave., Sanford, NC 27330 • (919) 566-8000  
10951 West Los Angeles Ave., Moorpark, CA 93021 • (805) 553-5000

Pentair Water Pool and Spa logo are trademarks of Pentair Water Pool and Spa, Inc. Other trademarks and trade names may be used in this document to refer to either the entities claiming the marks and names or their products. Pentair Water Pool and Spa Inc. disclaims proprietary interest in marks and names of others.  
Printed in U.S.A.

## P6RA', P6EA' and 'P6E' SERIES PUMP WITH TRAP

To avoid unneeded service calls, prevent possible injuries, and get the most out of your pump, READ THIS MANUAL CAREFULLY!

The Sta-Rite 'P6RA', 'P6EA' and 'P6E' Series Self-priming Centrifugal pumps:

- Are designed for use with swimming pools or as centrifugal pumps.

### Table of Contents

<b>Safety instructions</b> .....	<b>2-3</b>
<b>Installation</b> .....	<b>3-5</b>
<b>Electrical</b> .....	<b>5-7</b>
<b>Operation</b> .....	<b>8-9</b>
<b>Storage/Winterizing</b> .....	<b>9</b>
<b>Pump Service</b> .....	<b>9-10</b>
<b>Troubleshooting Guide</b> .....	<b>11</b>
<b>Repair Parts List</b> .....	<b>12-14</b>

## Technical Support

Sanford, North Carolina  
(8 A.M. to 5 P.M. EST)

Moorpark, California  
(8 A.M. to 5 P.M. PST)

Phone: (800) 831-7133

Fax: (800) 284-4151

www.pentairpool.com www.staritepool.com

## READ AND FOLLOW SAFETY INSTRUCTIONS!

 This is the safety alert symbol. When you see this symbol on your system or in this manual, look for one of the following signal words and be alert to the potential for personal injury.

 **DANGER** warns about hazards that will cause death, serious personal injury, or major property damage if ignored.

 **WARNING** warns about hazards that can cause death, serious personal injury, or major property damage if ignored.

 **CAUTION** warns about hazards that will or can cause minor personal injury or property damage if ignored.

NOTICE indicates special instructions not related to hazards.

Carefully read and follow all safety instructions in this manual and on equipment. Keep safety labels in good condition; replace if missing or damaged.

 **WARNING** Incorrectly installed or tested equipment may fail, causing severe injury or property damage.

Read and follow instructions in owner's manual when installing and operating equipment. Have a trained pool professional perform all pressure tests.

1. Do not connect system to a high pressure or city water system.

Max-E-Pro™ Pump Models				
HP	Energy Efficient Full-Rate	Energy Efficient Up-Rate	Standard Up-Rate	2-Speed
1/2	P6E6C-204L	-	-	-
3/4	P6E6D-205L	P6EA6D36-204	-	-
1	-	P6EA6E36-205	-	-
1	P6E6E-206L	P6EA6E-205L	P6RA6E-205L	-
1-1/2	P6E6F-207L	P6EA6F-206L	P6RA6F-206L	P6RA6YF-206L
1-1/2	-	P6EA6F36-206	-	-
1-3/4	-	P6EAA6F-216L	P6RAA6F-216L	-
2	P6E6G-208L	P6EA6G-207L	P6RA6G-207L	P6RA6YG-207L
2	-	P6EA6G36-207	-	-
2-1/2	-	P6EAA6G-208L	-	-
3	P6E6H-209L	-	-	-
3	P6E6H36-209	-	-	-

2. Use equipment only in a pool or spa installation.
3. Install pump with at least 2 hydraulically balanced main drains equipped with correctly installed, screw-fastened, anti-entrapment certified covers. See Page 4.
4. Trapped air in system can cause explosion. BE SURE all air is out of system before operating or testing equipment.

Before pressure testing, make the following safety checks:

- Check all clamps, bolts, lids, and system accessories before testing.
- Release all air in system before testing.
- Water pressure for test must be less than 25 PSI (7.5 kg/cm<sup>2</sup>).
- Water Temperature for test must be less than 100° F (38° C).
- Limit test to 24 hours. After test, visually check system to be sure it is ready for operation. Remove trap lid and retighten hand tight only.

NOTICE: These parameters apply to Sta-Rite equipment only. For non-Sta-Rite equipment, consult manufacturer.

## IMPORTANT SAFETY INSTRUCTIONS

Always follow basic safety precautions with this equipment, including the following.

**▲ WARNING** To reduce the risk of injury, do not permit children to use this product unless they are closely supervised at all times.

**▲ CAUTION** This pump is for use with permanently installed pools and may also be used with hot tubs and spas if so marked. Do not use with storable pools. A permanently installed pool is constructed in or on the ground or in a building such that it cannot be readily disassembled for storage. A storable pool is constructed so that it may be readily disassembled for storage and reassembled to its original integrity.

## SAVE THESE INSTRUCTIONS

## INSTALLATION

Only qualified, licensed personnel should install pump and wiring.

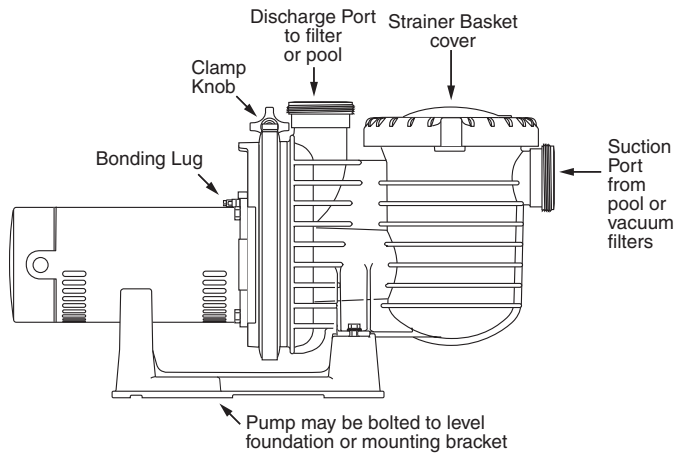

Figure 1

NOTICE: Port threads are: Internal - 2" NPT for direct connection to pipe. External - 3-1/4" Buttress. Fits Sta-Rite U11-200P Union Collar for quick disconnect pipe connection.

See Page 12 for Union Kits.

Pump mount must:

Be located away from corrosive or flammable chemicals.

Have enough ventilation to maintain air temperature at less than the maximum ambient temperature rating (Max. Amb.) listed on the motor model plate. If this pump is installed in an enclosure/pump house, the enclosure must have adequate ventilation and air circulation to keep the temperature in the enclosure at or below the motor's rated ambient temperature whenever the pump is running.

Be solid - Level - Rigid - Vibration free - Non-combustible. (To reduce vibration and pipe stress, bolt pump to mount.)

Allow pump suction inlet height to be as close to water level as possible.

Allow use of short, direct suction pipe (To reduce friction losses).

Allow for gate valves in suction and discharge piping.

Have adequate floor drainage to prevent flooding.

Be protected from excess moisture.

Allow adequate access for servicing pump and piping.

**▲ WARNING** Fire and burn hazard. Modern motors run at high temperatures. To reduce the risk of fire, do not allow leaves, debris, or foreign matter to collect around the pump motor. To avoid burns when handling the motor, let it cool for 20 minutes before trying to work on it.

**NOTICE:** Use Teflon tape or Plasto-Joint Stik<sup>1</sup> for making all threaded connections to the pump. Do not use pipe dope; pipe dope will cause stress cracking in the pump.

**NOTICE:** Pump suction and discharge connections have molded in thread stops. DO NOT try to screw pipe in beyond these stops.

### Teflon Taping Instructions:

Use only new or clean PVC pipe fittings.

Wrap male pipe threads with one to two layers of Teflon tape. Cover entire threaded portion of pipe.

Do not overtighten or tighten past thread stop in pump port!

If leaks occur, remove pipe, clean off old tape, rewrap with one to two additional layers of tape and remake the connection.

**NOTICE:** Support all piping connected with pump!

### Piping:

Use at least 2" IPS PVC (51mm) pipe. Increase size if a long run is needed.

To avoid strains on the pump, support both suction and discharge pipes independently. Place these supports near the pump.

To avoid a strain left by a gap at the last connection, start all piping at the pump and run pipe away from the pump.

Never use a suction pipe smaller than pump suction connection.

<sup>1</sup>Lake Chemical Co., Chicago, Illinois

To avoid airlocking, slope suction pipe slightly upward toward the pump.

**NOTICE:** To prevent flooding when removing pump for service, all flooded suction systems must have gate valves in suction and discharge pipes.

### Fittings:

Fittings restrict flow; for best efficiency use fewest possible fittings.

Avoid fittings which could cause an air trap.

Pool fittings must conform to International Association of Plumbing and Mechanical Officials (IAPMO) standards.

Use only non-entrapping suction fitting or double suction.

## POOL PUMP SUCTION REQUIREMENTS

**▲ WARNING** Pump suction is hazardous and can trap and drown or disembowel bathers. Do not use or operate swimming pools, spas, or hot tubs if a suction outlet cover is missing, broken, or loose. Follow the guidelines below for a pump installation which minimizes risk to users of pools, spas, and hot tubs.

### Entrapment Protection

The pump suction system must provide protection against the hazard of suction entrapment or hair entrapment/entanglement.

### Suction Outlet Covers

All suction outlet covers must be maintained. They must be replaced if cracked, broken, or missing.

See below for outlet cover certification requirements.

All suction outlets must have correctly installed, screw-fastened covers in place.

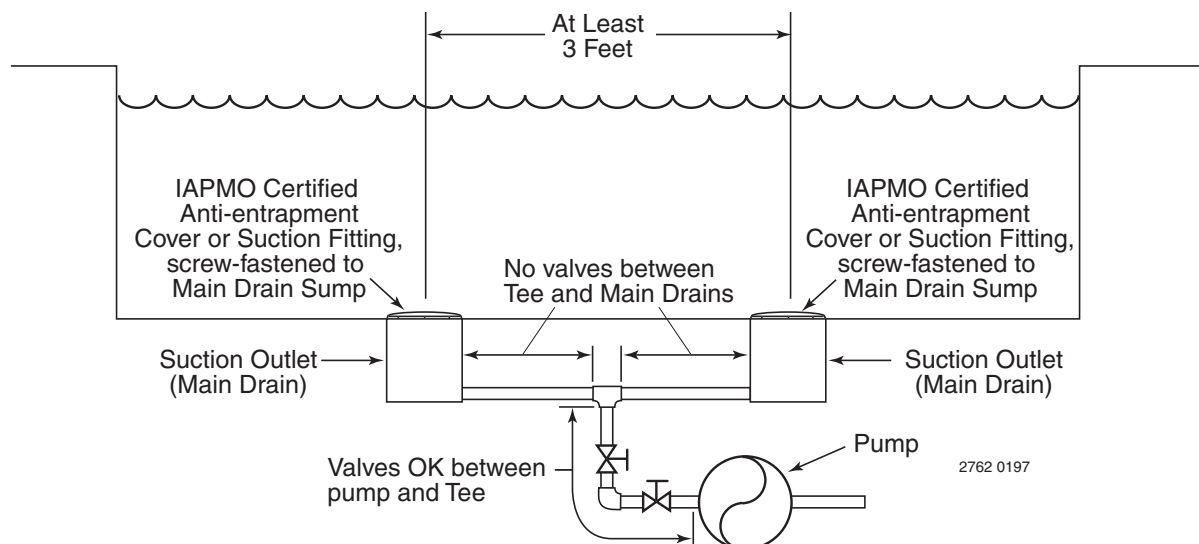

Figure 2 – Recommended pump suction layout.

## Testing and Certification

Suction outlet covers must have been tested by a nationally recognized testing laboratory and found to comply with the latest ASME/ANSI Specification for Suction Fittings For Use in Swimming Pools, Spas, Hot Tubs, and Whirlpool Bathtub Applications.

## Outlets Per Pump

Provide at least two hydraulically balanced main drains, with covers (see Page 5), for each swimming pool pump suction line. The centers of the main drains (suction fittings) must be at least three feet apart.

The system must be built so that it cannot operate with the pump drawing water from only one main drain (that is, there must be at least two main drains connected to the pump whenever it is running). (See Figure 2). However, if two main drains run into a single suction line, the single suction line may be equipped with a valve which will shutoff both main drains from the pump (see Figure 2).

More than one pump can be connected to a single suction line as long as the requirements above are met.

## Water Velocity

The maximum water velocity through any suction outlet must be 1.5 feet per second unless the outlet complies with the latest ASME/SNSI Specification for Suction Fittings For Use in Swimming Pools, Spas, Hot Tubs, and Whirlpool Bathtub Applications. In any case, do not exceed the suction fittings maximum designed flow rate.

If 100% of the pump's flow comes from the main drain system, the maximum water velocity in the pump suction hydraulic system must be six feet per second or less even if one main drain (suction fitting) is completely blocked. The flow through the remaining main drain(s) must comply with the latest ASME/ANSI Specification for Suction Fittings For Use in Swimming Pools, Spas, Hot Tubs, and Whirlpool Bathtub Applications.

## ELECTRICAL

### Notice

Due to wide variation in electrical equipment, power supply, and installation requirements, **this manual does not make specific recommendations concerning auxiliary equipment or fusing/wiring.**

Wire sizing, wire type, branch circuit fuse protection, motor starter, control equipment, and related items must meet National Electrical Code and local code requirements. Motors are supplied by several manufacturers and nameplate data (service factor, maximum amperage, etc.) will vary. Consult control manufacturer and motor nameplate on your pump to correctly choose and size motor starter and control equipment for your particular installation. Specific electrical questions or problems

should be addressed to the manufacturer of the electrical component in question.

⚠ Ground motor before connecting to electrical power supply. Failure to ground motor can cause

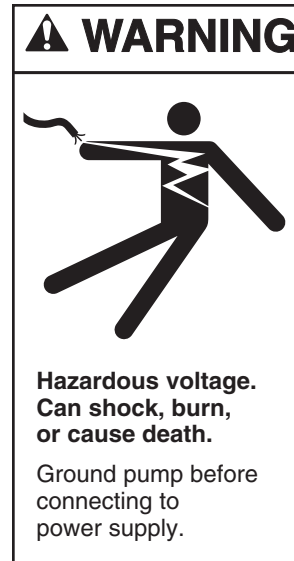

severe or fatal electrical shock hazard.

⚠ Do not ground to a gas supply line.

⚠ To avoid dangerous or fatal electrical shock, turn OFF power to motor before working on electrical connections.

⚠ Ground Fault Circuit Interrupter (GFCI) tripping indicates an electrical problem. If GFCI trips and will not reset, have a qualified electrician inspect and repair electrical system.

⚠ Exactly match supply

voltage to nameplate voltage. Incorrect voltage can cause fire or seriously damage motor and voids warranty. If in doubt consult a licensed electrician.

## Voltage/Phase

Voltage at motor must be not more than 10% above or below motor nameplate rated voltage or motor may overheat, causing overload tripping and reduced component life. If voltage is less than 90% or more than 110% of rated voltage when motor is running at full load, consult power company. **Do not try to connect 3-phase motors to single phase power supply or single phase motors to 3-phase power supply.**

## Emergency Shutoff

Install an Emergency Shutoff Switch near pool. Clearly mark this switch and mount it in a location that is accessible to bathers or pool operating personnel (e.g. lifeguards). Make sure that all lifeguards and pool personnel understand the switch's use in case of emergency (entrapment, electrical malfunction, etc).

## Grounding/Bonding

Install, ground, bond and wire motor according to local or National Electrical Code requirements.

Permanently ground motor. Use green ground terminal provided under motor canopy or access plate (See Figure 3); use size and type wire required by code. Connect motor ground terminal to electrical service ground.

Bond motor to pool structure. Use a solid copper conductor, size No. 8 AWG (8.4 sq.mm) or larger. Run wire from external bonding lug (see Figure 3) to

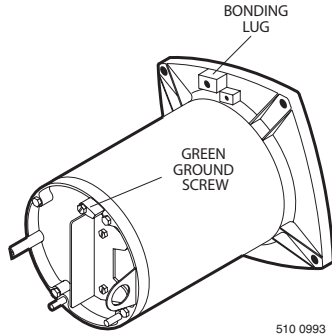

510 0993

Figure 3: Typical ground screw and bonding lug locations. reinforcing rod or mesh.

Connect a No. 8 AWG (8.4 sq.mm) solid copper bonding wire to the pressure wire connector provided on the motor housing and to all metal parts of the swimming pool, spa, or hot tub and to all electrical equipment, metal piping or conduit within 5 feet (1.5 m) of the inside walls of swimming pool, spa, or hot tub.

## Wiring

Pump must be permanently connected to circuit. See Figures 4A and 4B for wiring connection diagrams. Match wire and circuit breaker sizes to correct Fusing and Wiring Data Chart (Page 7). If other lights or appliances are also on the same circuit, be sure to add their amp loads to pump amp load. (If unsure how to do this or if this is confusing, consult a licensed electrician.) Use the load circuit breaker as the master on-off switch. Install a Ground Fault Circuit Interrupter (GFCI) in circuit; it will sense a short-circuit to ground and disconnect power before it becomes dangerous to pool users. For size of GFCI required and test procedures for GFCI, see manufacturer's instructions.

In case of power outage, check GFCI for tripping (which will prevent normal water circulation). Reset if necessary.

Make sure that motor nameplate connection diagram includes connection diagram for available voltage. If not, consult power company or a licensed electrician. Check rotation before attaching strainer and before making final connection to power supply. Pump should rotate counterclockwise when viewed through pump suction port.

To change rotation: Three phase motors: Reverse any two leads to motor. Single phase motors: Follow manufacturer's instructions to reverse.

**NOTICE:** If you do not use conduit when wiring motor, be sure to seal wire opening on end of motor to prevent dirt, bugs, etc., from entering motor.

**▲ WARNING** Risk of dangerous or fatal electrical shock. Be sure that power to the motor circuit is off before work-

ing on wiring, wiring connections, or motor. Re-install the motor end cover and all other wiring covers before turning on the power.

1. Turn off power.
2. Remove the motor end cover.

## To Wire a Single Speed, Single Voltage Motor

There are two terminals labeled L1 and L2. Attach the power leads to these terminals. Either wire may attach to either terminal.

## To Wire a Dual-Voltage Motor

Dual voltage motors have a plug to change from 230 volts (factory setting) to 115 volts).

1. If you have 230 volts motor supply voltage, confirm that the plug is set for 230 volts. The arrow on the plug will point to the 230 volt position. Note that plug only connects with one prong in this position.
2. If you have 115 volt supply, pull the plug straight up and place it on the two brass prongs as shown.

NOTE: Arrow is highlighted for clarity.

## To Wire a Two-Speed Motor

Wire the pump as shown in the diagram.



Figure 4A -Voltage Change Plug Set for 230 Volts



Figure 4B Voltage Change Plug Set for 115 Volts

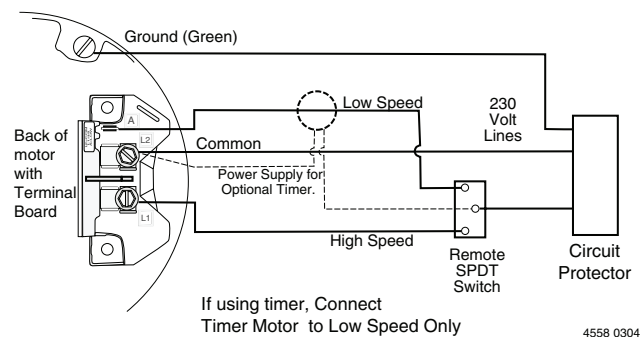

4558 0304

Minimum switch and timer amp rating must equal Branch Fuse Rating given in "Recommended Fusing and Wiring Data" table.

Figure 4C - 2-Speed Motor Wiring Diagram

TABLE I - RECOMMENDED FUSING AND WIRING DATA – P6E MODELS

Motor HP	Branch Fuse Rating Amps*	Max Load Amps	Voltage/ Hz/Phase	Serv. to Motor - Dist. in Ft. (M)		
				0-100' (0-30 M)	101-200' (30-60 M)	201-300' (60-90 M)
P6E Models:						
1/2	15	11.0	115/60/1	14(2)	10(5.5)	8(8.4)
3/4	20	13.8	115/60/1	12(3)	10(5.5)	8(8.4)
1	25	16.0	115/60/1	12(3)	8(8.4)	6(14)
1/2	15	5.5	230/60/1	14(2)	14(2)	14(2)
3/4	15	6.9	230/60/1	14(2)	14(2)	14(2)
1	15	8.0	230/60/1	14(2)	14(2)	14(2)
1-1/2	15	10.4	230/60/1	14(2)	12(3)	12(3)
2	15	11.2	230/60/1	14(2)	12(3)	12(3)
3	25	15.8	230/60/1	12(3)	12(3)	10(5.5)

\* Time delay fuses are recommended instead of standard fuses in any motor circuit.

} Wire Size AWG (mm<sup>2</sup>)

TABLE II - RECOMMENDED FUSING AND WIRING DATA – P6EA MODELS

Motor HP	Branch Fuse Rating Amps*	Max Load Amps	Voltage/ Hz/Phase	Serve to Motor - Dist. in Ft. (M)		
				0-100' (0-30 M)	101-200' (30-60 M)	201-300' (60-90 M)
1	20	13.8	115/60/1	12(3)	10(5.5)	8(8.4)
1-1/2	25	16.0	115/60/1	12(3)	8(8.4)	6(14)
1	15	6.9	230/60/1	14(2)	14(2)	14(2)
1-1/2	15	8.0	230/60/1	14(2)	14(2)	12(3)
1-3/4	15	10.4	230/60/1	14(2)	12(3)	12(3)
2	15	10.4	230/60/1	14(2)	12(3)	12(3)
2-1/2	15	11.2	230/60/1	14(2)	12(3)	12(3)
3/4	15	1.2	575/60/3	14(2)	14(2)	14(2)
1	15	1.5	575/60/3	14(2)	14(2)	14(2)
1-1/2	15	1.9	575/60/3	14(2)	14(2)	14(2)
2	15	3.2	575/60/3	14(2)	14(2)	14(2)
3	15	3.9	575/60/3	14(2)	14(2)	14(2)

\* Time delay fuses are recommended instead of standard fuses in any motor circuit.

} Wire Size AWG (mm<sup>2</sup>)

TABLE III - RECOMMENDED FUSING AND WIRING DATA – P6RA MODELS

Motor HP	Branch Fuse Rating Amps*	Max Load Amps	Voltage/ Hz/Phase	Serv. to Motor - Dist. in Ft. (M)		
				0-100' (0-30 M)	101-200' (30-60 M)	201-300' (60-90 M)
P6RA Models:						
1	20/15	15.3/7.6	115/230/60/1	12/14(3/2)	8/14(8.4/2)	6/14(14/2)
1-1/2	30	19.2	115/60/1	10(5.5)	8(8.4)	6(14)
1-1/2	15	9.6	230/60/1	14(2)	14(2)	12(3)
1-1/3	15	12.0	230/60/1	14(2)	12(3)	12(3)
2	15	12.0	230/60/1	14(2)	14(2)	12(3)
P6RA 2-Speed Models:						
1-1/2	15	9.2/2.5	230/60/1	14(2)	14(2)	12(3)
2	15	10.1/3.7	230/60/1	14(2)	14(2)	12(3)

\* Time delay fuses are recommended instead of standard fuses in any motor circuit.

} Wire Size AWG (mm<sup>2</sup>)

## OPERATION

**⚠** NEVER run pump dry. Running pump dry may damage seals, causing leakage and flooding. Fill pump with water before starting motor.

**⚠ CAUTION** Before removing trap cover:

1. STOP PUMP before proceeding.
2. CLOSE GATE VALVES in suction and discharge pipes.
3. RELEASE ALL PRESSURE from pump and piping system.
4. NEVER tighten or loosen clamp while pump is operating!

**⚠** If pump is being pressure tested, be sure pressure has been released before removing trap cover.

**⚠ WARNING**



**Hazardous suction. Can trap hair or body parts, causing severe injury or death.**

Do not block suction.

**⚠** Do not block pump suction. To do so with body may cause severe or fatal injury. Small children using pool must ALWAYS have close adult supervision.

**⚠ WARNING** Fire and burn hazard. Modern motors run at high temperatures. To reduce the risk of fire, do not allow leaves, debris, or foreign matter to collect around the pump motor. To avoid burns when handling the motor, let it cool for 20 minutes before trying to work on

it. An automatic internal cutoff switch protects the motor from heat damage during operation.

**NOTICE:** Maximum ambient temperature for motor operation must not exceed maximum ambient temperature rating on motor model plate.

### Priming Pump

Release all pressure from filter, pump, and piping system; see the filter owner's manual.

In a flooded suction system (water source higher than pump), pump will prime itself when suction and discharge valves are opened.

If pump is not in a flooded suction system, remove trap

cover handle ring and trap cover; fill trap and pump with water.

Do not lubricate the trap cover O-Ring. The original equipment O-Ring contains a permanent internal lubricant.

**NOTICE:** If you replace the O-Ring with a non-internally lubricated O-Ring, you may need to apply a silicone based lubricant.

Clean and inspect O-Ring; reinstall on trap.

Replace trap cover and handle ring on trap; turn handle ring clockwise to tighten cover.

**NOTICE:** Tighten trap cover handle ring by hand only (no wrenches)!

Pump should prime now. Priming time will depend on vertical length of suction lift and horizontal length of suction piping.

If pump does not prime, make sure that all valves are open, suction pipe end is under water, and that there are no leaks in suction pipe.

See Troubleshooting Guide, Page 11.

### Routine Maintenance

The only routine maintenance needed is inspection/cleaning of trap basket. Debris or trash that collects in basket will choke off water flow through the pump. Follow instructions below to clean trap:

1. Stop pump, close valves in suction and discharge, and release all pressure from system before proceeding.
2. Remove trap cover handle ring (turn counterclockwise). If necessary, tap handles gently with a rubber mallet.
3. Remove strainer basket and clean. Be sure all holes in basket are clear, flush basket with water and replace in trap with large opening at pipe connection port (between ribs provided). If basket is replaced backwards cover will not fit on trap body.
4. Clean and inspect lid O-Ring; reinstall on trap.
5. Clean O-Ring groove on trap body and replace cover and handle ring. To help keep cover from sticking, tighten hand tight only.
6. Prime pump (see priming instructions).



## Draining Pump

1. Pump down water level below all inlets to the pool.



2. **⚠** To avoid dangerous or fatal electrical shock hazard, turn OFF power to motor before draining pump.
2. Remove trap cover and use low pressure air to blow accumulated water from the piping system. Lugs have been provided on the trap lid to use a lever or pry bar for loosening.
3. Cap inlet piping after draining to keep water out of the pipes.
4. To prevent pump from freezing, remove trap cover and drain the tank body through the drain

plugs (Key No. 19, Page 12). Clean pump and trap basket thoroughly; replace trap cover.

NOTICE: Tighten trap cover by hand only (no wrenches)! Use a rubber mallet only if necessary to remove cover! If pump is not anchored, use caution not to break attached piping!

5. Be sure motor is kept dry and covered.

## Storage/Winterizing:

**⚠ WARNING** Explosion hazard. Purging the system with compressed air can cause components to explode, with risk of severe injury or death to anyone nearby. Use only a low pressure (below 5 PSI), high volume blower when air purging the pump, filter, or piping.

NOTICE: Allowing pump to freeze will damage pump and void warranty!

NOTICE: Do not use anti-freeze solutions (except propylene glycol) in your pool/spa system. Propylene glycol is non-toxic and will not damage plastic system components; other anti-freezes are highly toxic and may damage plastic components in the system.

Drain all water from pump and piping when expecting freezing temperatures or when storing pump for a long time (see instructions below).

Keep motor dry and covered during storage.

To avoid condensation/corrosion problems, do not cover pump with plastic.

For outdoor/unprotected installations:

1. Gravity drain system as far as possible.
2. Protect areas which retain water with non-toxic propylene glycol antifreeze ("RV antifreeze").
3. Enclose entire system in a weatherproof enclosure.

4. To avoid condensation/corrosion damage, allow ventilation; do not wrap system in plastic.
5. Use a 40% propylene glycol/60% water solution to protect pump to -50°F (-46°C).

## Startup For Winterized Equipment

1. Remove any temporary weather protection placed around system.
2. Follow filter manufacturer's instructions for reactivation of the filter.
3. Inspect all electrical wiring for damage or deterioration over the shutdown period. Have a qualified serviceman repair wiring as needed.
4. Inspect and tighten all watertight connections.
5. Open all valves in suction and return piping.
6. Remove any winterizing plugs in piping system.
7. Drain all antifreeze from system.
8. Close all drain valves and replace all drain plugs in piping system.
9. Prime pump according to instructions on Page 8.

## PUMP SERVICE

Pump should only be serviced by qualified personnel.

For best results, use only genuine Sta-Rite factory parts.

Be sure to prime pump (Page 8) before starting.

**⚠ CAUTION** Before removing clamp or trap cover:

1. STOP PUMP before proceeding.
2. CLOSE GATE VALVES in suction and discharge pipes.
3. RELEASE ALL PRESSURE from pump and piping system.
4. NEVER tighten or loosen clamp while pump is operating!



**⚠** To avoid dangerous or fatal electrical shock hazard, turn OFF power to motor before working on pump or motor.

No lubrication or regular maintenance is needed beyond reasonable care and periodic cleaning of strainer basket.

If shaft seal is worn or damaged, repair as follows:

### Pump Disassembly/Removing Old Seal

Disconnect power to pump motor.

**⚠** Be sure gate valves on suction and return piping are closed before starting work.

Release all pressure by opening all vents before starting work.

1. Drain pump by removing drain plugs on bottom of pump body and trap body.
2. Be sure there is no pressure in trap body; remove cover (unscrew by turning handle ring counterclockwise).
3. Remove clamp holding pump halves together. Motor and seal plate assembly can now be pulled away from pump body.
4. Remove five screws and washers holding diffuser to seal plate. Remove diffuser.
5. Remove motor canopy. Being careful not to touch capacitor terminals, loosen capacitor clamp and move capacitor to one side.
6. Hold shaft with 7/16" open-end wrench on motor shaft flats.
7. Unscrew impeller from shaft (turn counterclockwise when facing it).  
NOTICE: On models with impeller screw: Remove impeller screw (left hand thread - turn clockwise) and gasket before removing impeller. Inspect gasket for damage, cracks, etc. Replace if damaged.
8. Pull rotating member of seal off of impeller sleeve; clean sleeve.
9. Remove four screws holding seal plate to motor.
10. Place seal plate face down on flat surface and tap out ceramic seat.
11. Clean seal cavity in seal plate and clean motor shaft.

### Pump Reassembly/Installing New Seal

1. Ceramic seat must be clean and free of dirt, grease, dust, etc. Wet outer edge of rubber cup on ceramic seat with small amount of liquid detergent; press

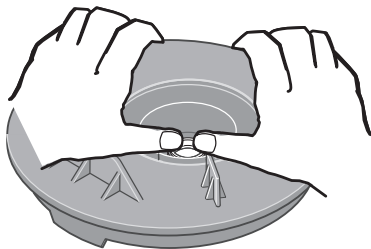

Figure 5: Press seal into seal plate

ceramic seat into seal plate firmly and squarely with finger pressure (Figure 5).

2. If ceramic seat will not locate properly, remove it, place face up on bench and reclean cavity. Ceramic seat should now locate.
3. If seat still will not locate properly, place a cardboard washer over the polished face and use a piece of 3/4" (19mm) standard pipe for pressing purposes.  
NOTICE: Be sure not to scratch or mar polished surface or seal will leak.
4. Remount seal plate on motor. Tighten bolts to 60-80 inch-lbs. (69-92 kg/cm) torque.
5. Apply a small amount of liquid detergent to inside diameter of rotating half of seal.
6. Slide rotating seal member, polished face last, over impeller sleeve until rubber drive ring hits shoulder.  
NOTICE: Be sure not to nick or scratch polished seal face; seal will leak if face is damaged.
7. Screw impeller onto shaft (clockwise); this will automatically locate seal in seal plate.  
NOTICE: On models with impeller screw: Install impeller gasket and lock screw (left-hand thread - turn counterclockwise). Torque lock screw to 50-55 inch-lbs. (57.6-63 kg/cm).
8. Mount diffuser on seal plate; tighten screws to 10-14 inch-lbs. (11.2-16.1 kg/cm) torque.
9. Assemble motor and seal plate to volute; be sure clamp is properly seated.  
NOTICE: Clamp knob can be located in any position around volute; if it is moved after assembly, tighten knob while tapping around clamp to assist sealing. Do not move clamp while pump is full of water.

**⚠ WARNING** Hazardous pressure. Release all pressure from pump and piping system before working on pump or attempting to adjust or remove clamp. Clamp may blow off of pump if adjusted under pressure.

10. Prime pump according to instructions on Page 8.

## TROUBLESHOOTING GUIDE

**⚠** Read and understand safety and operating instructions in this manual before doing any work on pump!

**⚠** Only qualified personnel should electrically test pump motor!

### FAILURE TO PUMP; REDUCED CAPACITY OR DISCHARGE PRESSURE

#### Suction leaks/lost prime:

1. Pump must be primed; make sure that pump volute and trap are full of water. See priming instructions, Page 8.
2. Make sure there are no leaks in suction piping.
3. Make sure suction pipe inlet is well below the water level to prevent pump from sucking air.
4. Suction lift of 10 to 20 feet (3-6 M) will reduce performance. Suction lift of more than 20 feet (6 M) will prevent pumping and cause pump to lose prime. In either case, move pump closer (vertically) to water source. Make sure suction pipe is large enough.

#### Clogged pipe/trap/impeller, worn impeller:

5. Make sure suction trap is not clogged; if it is, clean trap and strainer.
6. Make sure impeller is not clogged (follow steps 1 through 7 under "Removing Old Seal", Page 10; check impeller for clogging; follow steps 7 through 10 under "Installing New Seal", Page 10, for re-assembly).
7. Impeller and diffuser may be worn. If so, order replacement parts from Repair Parts List, Page 12.
8. Pump may be trying to push too high a column of water. If so, a "higher head" pump is needed.



#### Electrical:

9. Pump may be running too slowly; check voltage at motor terminals and at meter while pump is running. If low, see wiring instructions or consult power company. Check for loose connections.
10. Pump may be too hot.
  - A. Check line voltage; if less than 90% or more than 110% of rated voltage consult a licensed electrician.
  - B. Increase ventilation.
  - C. Reduce ambient temperature.
  - D. Tighten any loose connections.
11. No Voltage on one phase (three phase units); Check phase voltage on line side of starter contactor. Isolate open circuit (circuit breaker, fuse, broken connections, etc.)
12. Wrong Direction of rotation
  - A. Reverse rotation of three phase motor by interchanging any two leads.
  - B. See manufacturer's instructions for reversing single phase motor.

### MECHANICAL TROUBLES AND NOISE

1. If suction and discharge piping are not adequately supported, pump assembly will be strained. See "Installation", Page 3.
2. Do not mount pump on a wooden platform! Securely mount on concrete platform for quietest performance.

**Box A**

**REPAIR PARTS LIST**

**P6E, P6EA, P6RA  
MAX-E-PRO™ POOL PUMP  
1/2 through 3 HP Models**

For quick disconnect pipe connections, purchase separately:  
 Pkg. 188 2" Slip 1/2 Union Kit or  
 Pkg. 189 2" NPT 1/2 Union Kit.  
 Includes 2 each:  
 U11-200P Union Collar  
 U9-362 O-Ring  
 U11-196P 2" Slip adapter or  
 U11-199P 2" NPT adapter.

Key No.	Part Description	Qty.	Part No.
1	Motor	1	Chart at Right
2	#10-32x1/2" Screw	1	U30-692SS
2A	Lock Washer	1	U43-22SS
3	Bonding Lug	1	U17-568
4	Water Slinger	1	17351-0009
5	Seal Plate Kit (Incl. Key Nos. 6, 7)	1	C203-194P
6	O-Ring	1	U9-228A
7	Shaft Seal	1	37400-0028S
8	Clamp Knob	1	C19-37A
9	Clamp	1	WC36-22
10	Impeller	1	Chart at Right
10A	Impeller Screw O-Ring	1	35505-1426
10B	Impeller Screw	1	Chart at Right
11	Diffuser	1	Chart at Right
12	Diffuser O-Ring	1	U9-374
13	#8 Lock Washer	5	U43-21SS
14	Screw (w/C1-271P Diffuser)	5	U30-922SS
14	Screw (w/C1-271P1 Diffuser)	5	U30-542SS
15	Tank Body Assembly****	1	17307-0110S
16	Trap Cover Assembly**	1	17307-0111S
17	Trap O-Ring	1	35505-1440
18	Basket	1	C8-58P
19	1/4" NPT Drain Plug	2	U178-920P
20	Base Washer	2	U43-41SS
21	Base Screw	2	U30-918SS
22	Base w/Motor Pad***	1	C104-78P
23	Motor Pad	1	C35-43
24	3/8-16x1" Hex Hd. Screw	4	U30-74SS
•	Voltage Sticker - 230 Volts (Single voltage models only)		U27-68
•	Voltage Sticker - 115/230 Volts (Dual voltage models only)		U27-153
•	Tag, "CAUTION, WARNING (bonding)"		61002-0002
•	Decal, "Do not overtighten..."		U27-644
•	Nameplate		32155-7117

Parts are common to all models listed except as noted;  
 Key Nos. 1, Motor; 10, Impeller; and 11, Diffuser are listed below .

Model No.	HP	Motor No. (Key No. 1)	Impeller (Key No. 10)	Diffuser (Key No. 11)
115/230 Volt				
P6E6C-204L	1/2	AE100CHL	C105-238PX	C1-271P1
P6E6D-205L	3/4	AE100DHL	C105-238P	C1-271P1
P6E6E-206L	1	AE100EHL	C105-238PB	C1-271P1
P6EA6E-205L	1	AE100ELL	C105-238P	C1-271P1
P6RA6E-205L	1	A100ELL	C105-238P	C1-271P1
P6EA6F-206L	1-1/2	AE100FLL	C105-238PB	C1-271P1
P6RA6F-206L	1-1/2	A100FLL	C105-238PB	C1-271P1
230 Volt				
P6E6F-207L*	1-1/2	AE100FHL	17307-0116	C1-271PA
P6EA6F-216L*	1-3/4	AE100F5LL	C105-238PDCA	C1-271P
P6RA6F-216L*	1-3/4	A100F5LL	C105-238PDCA	C1-271P
P6E6G-208L*	2	AE100GHL	17307-0117	C1-271PA
P6EA6G-207L*	2	AE100GLL	17307-0116	C1-271PA
P6RA6G-207L*	2	A100GHL	17307-0116	C1-271PA
P6EA6G-208L*	2-1/2	AE100G5LL	17307-0117	C1-271PA
P6E6H-209L*	3	AE100HLL	17307-0118	C1-271PA
2-Speed				
P6RA6YF-206L**	1-1/2-1/4	A100FLL-Y	C105-238PBA	C1-271P1
P6RA6YG-207L*	2-1/3	A100GLL-Y	17307-0116	C1-271PA

\*Uses Key No. 10B Impeller Screw No. 37337-6080.

\*\* Uses Key No. 10B Impeller Screw No. 37337-6081 .

• Not illustrated.

\*\* Includes Trap Cover, Trap Ring and Trap Cover O-Ring.

\*\*\* Model P6E6H uses Base No. C104-79P and Motor Pad No. C35-44.

\*\*\*\* Includes Trap Body, Basket, Drain Plugs, and Trap Cover Assembly.

**P6E, P6EA, P6RA  
MAX-E-PRO™ POOL PUMP  
1/2 through 3 HP Models**

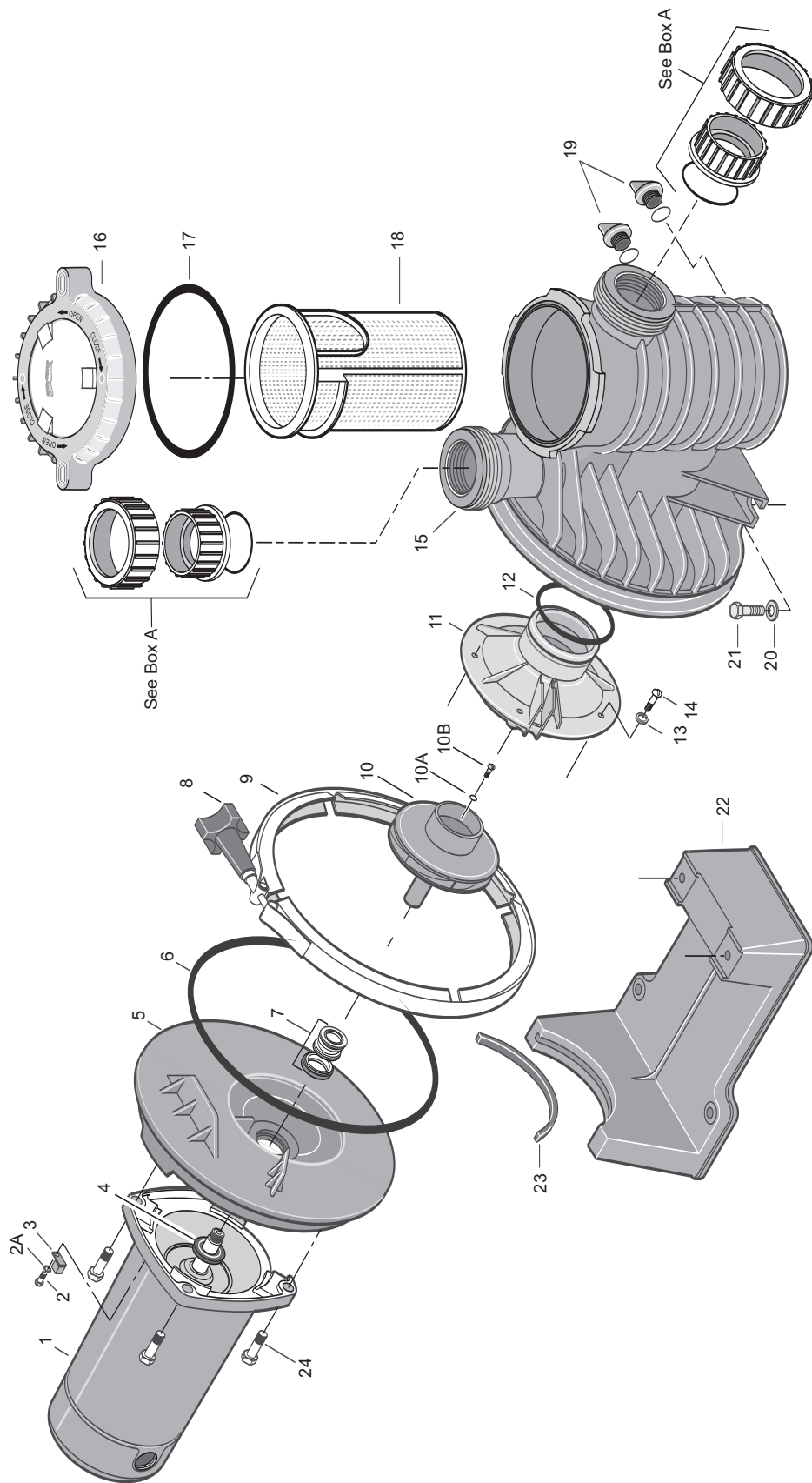

4285 1102

P6EA6D36-204, P6EA6E36-205  
MAX-E-PRO™ POOL PUMP  
3/4 & 1 HP Models

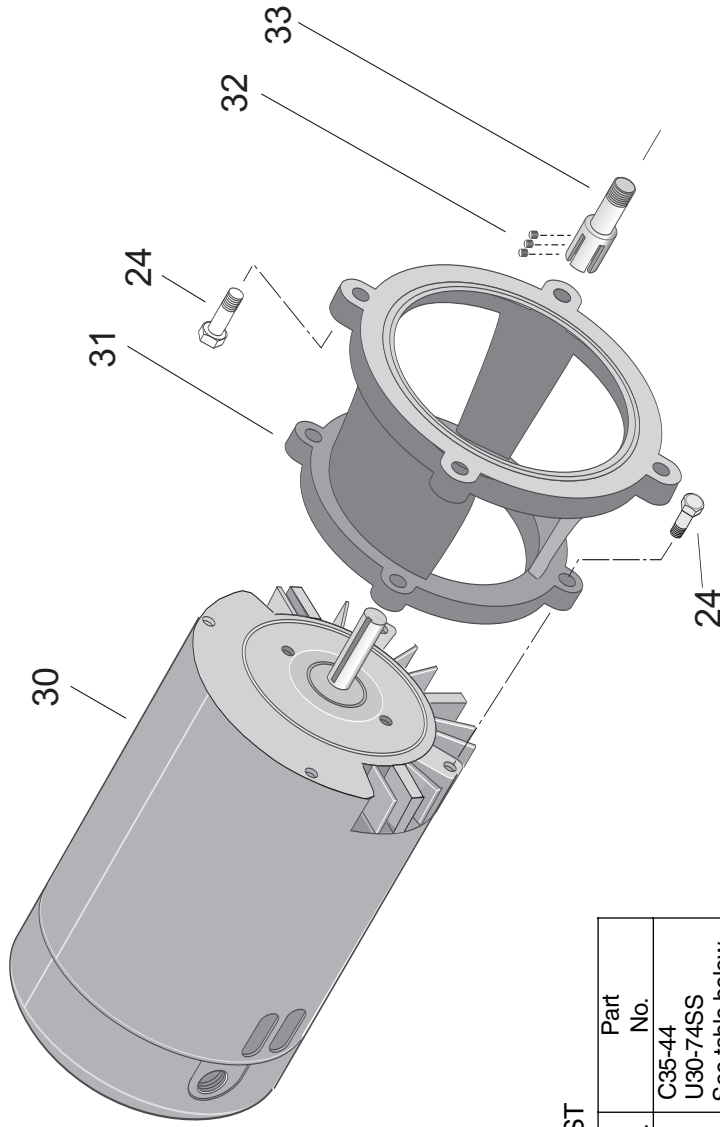

For all other components, see exploded view on page 13 and REPAIR PARTS LIST on page 12.

REPAIR PARTS LIST

Key No.	Part Description	Qty.	Part No.
23	Motor Pad	1	C35-44
24	3/8-16x1" Hex Hd. Screw	8	U30-74SS
30	Motor	1	See table below
31	Pump Adapter	1	C2-84
32	Set Screw	3	U30-754SS
33	Stub Shaft	1	C10-41SS

MAX-E-PRO Pool Pumps, 575 Volts, 3-Phase Models:						
Model No.	HP	V/Hz/PH	Motor No.	Impeller	Diffuser	Motor Base
P6EA6D36-204*	3/4	575/60/3	16502-0024	C105-238PXA1	C1-271P1	C104-79P
P6EA6E36-205*	1	575/60/3	16503-0024	C105-238PA1	C1-271P1	C104-79P
P6EA6F36-206	1-1/2	575/60/3	62001-1019	C105-238PBA	C1-271P1	C104-78P
P6EA6G36-207	2	575/60/3	62003-2087	17307-0116	C1-271PA	C104-78P
P6E6H36-209	3	575/60/3	62001-1021	17307-0118	C1-271PA	C104-79P

\* Models with the \* take the following additional parts: C2-84 Pump Adapter (1), C10-41SS Stub Shaft (1), U30-754SS Set Screw (3), U30-74SS Screw 3/8-16X1" Lg (8).  
All 3-phase models use Key No. 10A Impeller Screw O-ring and Key No. 10B Impeller Screw No. 37337-6080 .

## NOTES

**STA-RITE<sup>®</sup>**