

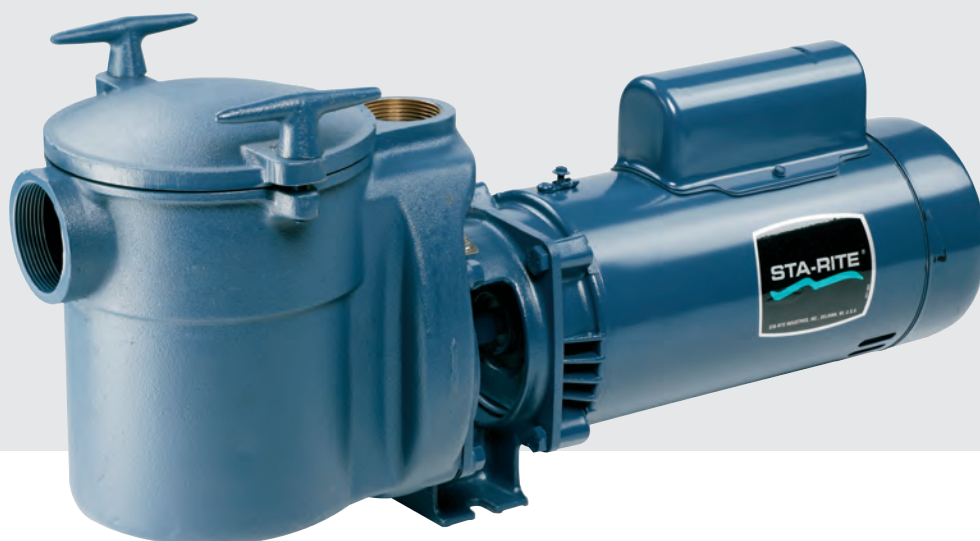

## CF Series™ Self-Priming Bronze Pumps with Integral Strainer



***For residential and commercial swimming pools and spas. Maximum suction lift is 8 ft.***

CF Series self-priming centrifugal pumps are available in  $\frac{3}{4}$  to 3 HP models and feature all bronze construction with an integral hair and lint strainer. Motors are open drip-proof type, NEMA® Series “C” flange design with a stainless steel shaft extension. The non-clogging semi-open impeller is coupled to the motor by an adjustable stub shaft. Suitable for outdoor installation.

### Standard Features

- All bronze construction provides exceptional performance under heavy duty swimming pool applications – proven durability for many years of service.
- Available with 5" or 6" hair and lint strainers integral with pump.
- Precision-molded ABS strainer baskets feature lock-in design for secure fit and are easily cleanable.
- Bronze semi-open, non-clogging impeller is precision balanced for smooth operation and long seal life.
- Designed for easy serviceability – motor, impeller and seal can be removed without disturbing piping.
- Motor components are protected and easily accessible under “control room” end canopy.

# CF Series™

Self-Priming Bronze Pumps With Integral Strainer

## Performance Curves

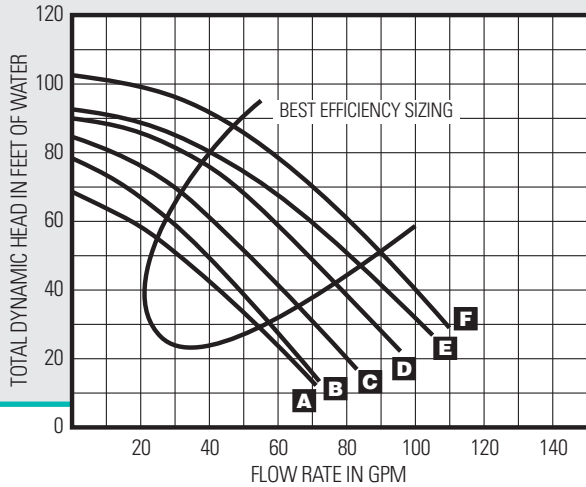

- KEY**
- A. CFADL
  - B. CFAEL
  - C. CFAFL
  - D. CF6EFL/CFAEGL
  - E. CF6EGL/CFAA EGL
  - F. CF6H/CF6H3

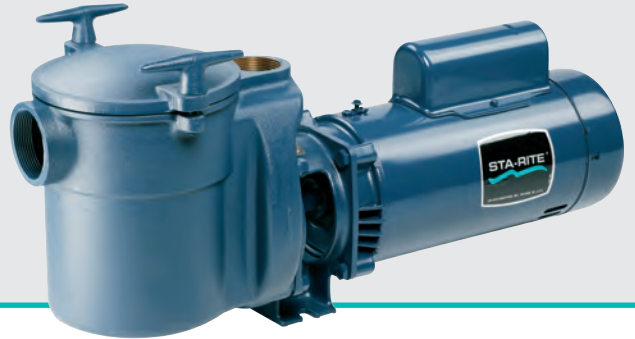

For detailed efficiency curves for each model, please contact the factory.

## MATERIALS AND DESIGN

- **Hair and Lint Strainer**  
Integrally cast to pump body
- **Material**  
Bronze body, cover and locking handles
- **Size**  
5" – 2" NPT Suction Port  
6" – 2" NPT Suction Port
- **Basket**  
Molded ABS; lock-in design positioned completely below the inlet port of the strainer body.

## Pump Body

Volute type, back pull-out

- **Port Size**  
1½" NPT Discharge Port
- **Material**  
Red Brass
- **Motor Adapter**  
Bronze, built-in mounting foot
- **Impeller**  
Bronze semi-open type

## Motor

- **Frame Size**  
NEMA® "C" flange, 48 frame thru 2 HP;  
3 HP is 56 frame
  - **Shaft**  
Stainless steel, keyed
  - **Design**  
¾ -3 HP, 3450 RPM, open drip-proof, single phase, continuous duty.  
65 BHP – Split phase  
95-1.65 BHP – Capacitor Start/Induction Run  
2.20-2.60 BHP – Capacitor Start/Capacitor Run  
3.3 BHP – Capacitor Start/Induction Run
  - **Bearings**  
Sealed ball type, permanently lubricated
  - **Thermal Overload Protection**  
Internal, automatic reset. 3-phase model requires external thermal overload protector
- ## Electrical
- **Power Supply Required**  
Single phase – 115/230V or 230V only (1½ to 3 HP)  
Three Phase – 230/460 Volts
  - **Maximum Limits**  
Liquid Temperature: 125°F  
Ambient Air Temperature: 122°F  
pH Range: 4-9.



## CF Commercial Pump

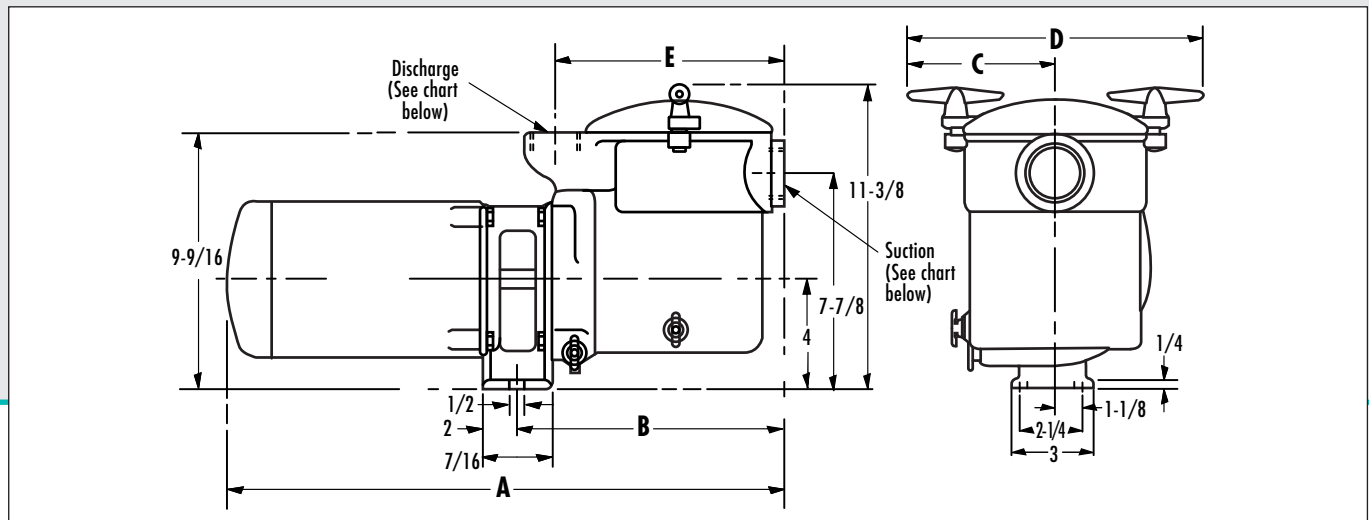

### Outline Dimensions

Catalog Number	A	B	C	D	E
<b>CF/CF6 SERIES</b>					
CF6EFL*	22 $\frac{5}{16}$	8 $\frac{5}{16}$	4 $\frac{5}{16}$	10 $\frac{3}{4}$	8 $\frac{5}{16}$
CF6EGL*	23 $\frac{3}{16}$	8 $\frac{1}{16}$	5 $\frac{5}{16}$	10 $\frac{3}{4}$	8 $\frac{5}{16}$
CF6H	23 $\frac{1}{2}$	8 $\frac{1}{16}$	5 $\frac{5}{16}$	10 $\frac{3}{4}$	8 $\frac{5}{16}$
CF6H3	21 $\frac{15}{16}$	8 $\frac{1}{16}$	5 $\frac{5}{16}$	10 $\frac{3}{4}$	9 $\frac{5}{16}$
<b>CFA SERIES</b>					
CFADL	21 $\frac{1}{16}$	8 $\frac{5}{16}$	4 $\frac{5}{16}$	9 $\frac{3}{4}$	7 $\frac{5}{16}$
CFAEL	21 $\frac{1}{16}$	8 $\frac{5}{16}$	4 $\frac{5}{16}$	9 $\frac{3}{4}$	7 $\frac{5}{16}$
CFAFL	22 $\frac{15}{16}$	8 $\frac{5}{16}$	4 $\frac{5}{16}$	9 $\frac{3}{4}$	7 $\frac{5}{16}$
CFAEGL*	22 $\frac{5}{16}$	8 $\frac{5}{16}$	4 $\frac{5}{16}$	9 $\frac{3}{4}$	7 $\frac{5}{16}$
CFAAEGl*	23 $\frac{1}{2}$	8 $\frac{5}{16}$	4 $\frac{5}{16}$	9 $\frac{3}{4}$	7 $\frac{5}{16}$

\* Energy-saving Capacitor Start/Capacitor Run motor design.  
575 volt models available. Consult factory.

All dimensions shown in inches.

### Ordering Information

Catalog Number	Nominal HP	Trap Size	Motor Voltage	Max. Load Amps	PORT SIZE		Approx. Ship. Weight (lbs.)
					Suction	Discharge	
<b>HIGH SERVICE FACTOR – CF SERIES</b>							
CF6EFL*	1 $\frac{1}{2}$	6"	230	12.0	2"	1 $\frac{1}{2}$ "	65
CF6EGL*	2	6"	230	14.0	2"	1 $\frac{1}{2}$ "	70
CF6H	3	6"	230	17.2	2"	1 $\frac{1}{2}$ "	72
CF6H3	3	6"	230/460	9.0/4.5	2"	1 $\frac{1}{2}$ "	58
<b>LOW SERVICE FACTOR – CFA SERIES</b>							
CFADL	$\frac{3}{4}$	5"	115/230	12.4/6.2	2"	1 $\frac{1}{2}$ "	46
CFAEL	1	5"	115/230	15.8/7.9	2"	1 $\frac{1}{2}$ "	54
CFAFL	1 $\frac{1}{2}$	5"	115/230	20.0/10.0	2"	1 $\frac{1}{2}$ "	55
CFAEGL*	2	5"	230	11.2	2"	1 $\frac{1}{2}$ "	63
CFAAEGl*	2 $\frac{1}{2}$	5"	230	13.2	2"	1 $\frac{1}{2}$ "	67

All dimensions shown in inches.

**NOTE:** 3 HP model are not UL listed.

# CF Series™

## Self-Priming Bronze Pumps With Integral Strainer

### ENGINEERING SPECIFICATIONS

- Recirculating pump shall be Sta-Rite Model No. \_\_\_\_\_.  
Bronze Pump Series, single phase 60 Hz.

### General Notes

- Install pump in a cool, dry, well vented location away from pool heaters, and chemical storage.
- Pump should be firmly mounted with pipe supported, to prevent vibration and undue operational noise.
- Allow 12" minimum clearance behind motor for servicing.
- Motor overheating may be caused by a voltage drop or excessive voltage. Be sure that wire size and voltage input is properly regulated.

### Specifications

- The recirculating pump shall be a self-priming, single suction, centrifugal type pump with integral hair and lint strainer installed as shown in the plans.
- The pump body and hair and lint strainer shall be cast of red brass material. The strainer body shall have a red brass lid and attached to the strainer body by means of the two threaded lock handles and sealed by means of an O-ring. The strainer basket shall be a lock-in design positioned completely below the inlet port of the strainer body. The basket shall be molded of high impact ABS material and shall be easily cleanable. The strainer assembly shall be capable of holding 30 psi water pressure during any hydrostatic testing of the piping installation. The trap shall have a removable drain plug, for winterizing.
- The pump body and intermediate motor adapter bracket shall be joined by means of four stainless steel capscrews and sealed with a fiber gasket. The pump shall be designed to allow removal of the motor and all moving parts of the pump without disturbing the piping. The body shall have a winterizing drain plug. The pump impeller shall be of a semi-open design, balanced, non-overloading, and cast of red brass material. The impeller shall have a threaded hub keyed for attachment to the bronze stub shaft. The stub shaft shall attach to the keyed motor shaft by means of three set screws which allow adjustment for proper impeller rotating clearance.

- The pump motor shall attach to the intermediate adapter of the pump with stainless steel capscrews. The motor stub shaft shall be sealed in the pump body by means of a mechanical cup-type seal whose stationary element shall be of stainless steel, carbon and neoprene and whose rotating elements shall be of ceramic. The seal shall be a highly polished and drip-proof design. The motor shall be of the open drip-proof type, NEMA® Series "C" flange design with a stainless steel shaft extension. The motor shall have all serviceable controls and components under a removable canopy at the rear of the motor for protection against weather and dirt. The motor shall have sealed ball bearings at both shaft and control end. The motor shall have a 50° C ambient or higher rating. Single-phase motors shall have an internal thermal overload protector of the automatic reset type. The motor shall be of the continuous duty type, suitable for outdoor installation. An external bonding lug shall be provided.
- The pump mounting base shall have bolt lugs to anchor the pump to the mounting surface.
- The motor shall be a \_\_\_\_\_ HP, \_\_\_\_\_ phase, 60 Hz, 3450 RPM for service on \_\_\_\_\_ volt electrical supply. The pump and motor shall be non-overloading at any point on the performance curve. The pump shall be rated for \_\_\_\_\_ GPM at \_\_\_\_\_ TDH. The pump and motor combination shall carry listing by Underwriter's Laboratories (UL). The pump shall be tested and certified by a nationally recognized testing laboratory to conform to National Sanitation Foundation Standard 50.



Phone: 800-831-7133

Fax: 800-284-4151

[www.pentairpool.com](http://www.pentairpool.com)

[www.starite.com](http://www.starite.com)